

Agilent 8901B Modulation Analyzer (150 kHz–1300 MHz) and Agilent 11722A Sensor Module (100 kHz– 2600 MHz)

Four Instruments In One

Data Sheet

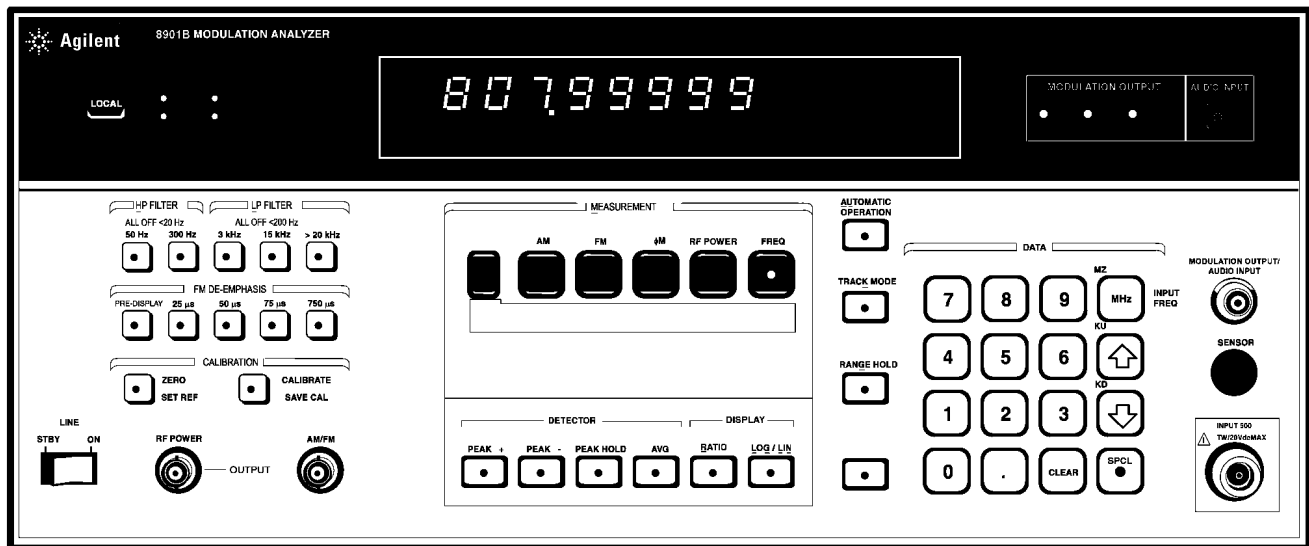

- **RF Power: ± 0.02 dB instrumentation accuracy**
- **RF Frequency: 10 Hz resolution**
- **AM and FM: 1% accuracy**
- **ϕ M: 3% accuracy**
- **Audio Characterization**
AC Volts: $\pm 4\%$ accuracy
Frequency: 6 digits of resolution
Distortion: ± 1 dB accuracy

The Agilent Technologies 8901B Modulation Analyzer combines four precise measurement functions into one fully automatic, GPIB programmable instrument. It includes a power meter, modulation analyzer, frequency counter, and audio analyzer. For precise signal analysis, the 8901B Modulation Analyzer provides the performance you need, the features you want, and the reliability and serviceability you expect.

RF Power delivers the accuracy and resolution of a high performance power meter. The 8901B with the Agilent Technologies 11722A Sensor Module measures power from +30 dBm to -20 dBm at frequencies from 100 kHz to 2.6 GHz. The 8901B accepts all Agilent Technologies 8480 series power sensors for extended measurement capability.

AM and FM measurements offer 1% accuracy (3% accuracy for ϕ M) and fast one-key operation. The 8901B has extremely low internal noise, and very low AM/ ϕ M and ϕ M/AM conversion, for accurately measuring residual and incidental AM, FM and ϕ M on a wide range of simple and complex modulated signals.

RF Frequency of complex modulated signals can be difficult to measure, but not with the 8901B. Automatically tuning to the largest input signal or to any user specified frequency, the 8901B counts with 10 Hz resolution.

Audio distortion, frequency, and level measurements provide comprehensive characterization of the modulation signal.



Agilent Technologies

Innovating the HP Way

Agilent 8901B Modulation Analyzer and Agilent 11722A Sensor Module

Independently selectable high-pass and low-pass filters match the post-detection bandwidth to the application.

Four standard de-emphasis networks are available for FM measurements. Using the Pre-display key, the de-emphasis networks are positioned before the displayed measurement circuit, to display "de-emphasized" FM deviation.

Zero the 11722A Sensor Module without removing it from the device under test.

Accurate 1mW reference for RF power calibration

AM/FM calibrator provides extremely accurate signals for modulation calibration. AM depth and FM deviation are calibrated to 0.1% accuracy.

Recorder output provides a dc voltage proportional to the measured result.

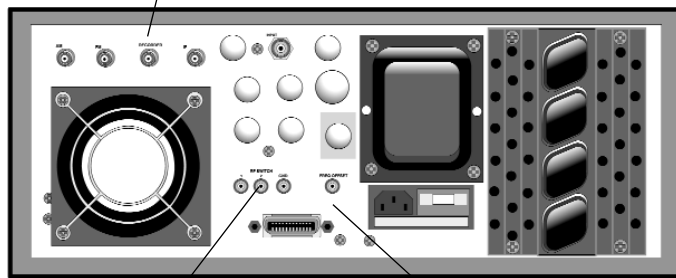

Remote control output for user configured power sensor/receiver input switch.

TTL level indicates Frequency Offset Mode.

Indicators display current GPIB STATUS.

Large 10-digit LED display for all measured results and error messages

In Track Mode, the Analyzer continuously tracks a swept signal. Range Hold freezes the instrument settings at their current value.

Store and recall instrument settings in eight non-volatile memory locations.

Enter RF Power calibration factors into non-volatile memory for automatic compensation of power sensor efficiency and mismatch loss.

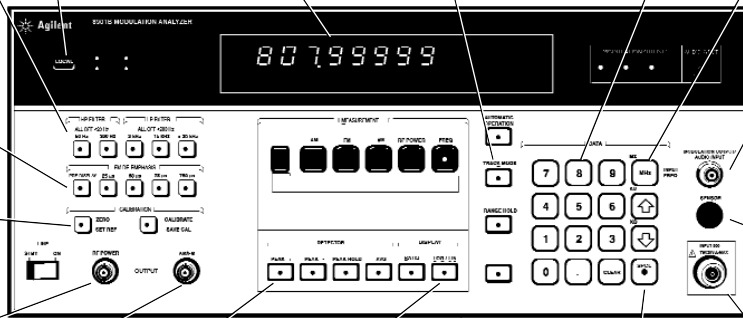

This connector has two functions. It serves as a recovered modulation output for external measurements, or external audio input for ac level, frequency or distortion measurements.

The Analyzer automatically recognizes which power sensor is used and sets the appropriate power ranges.

Modulation detector keys select positive peak, negative peak, \pm peak/2, average, or rms detectors. Peak Hold is used with either peak detector for measuring transients.

Selectable formats display results in the units desired.

Pull-out information cards for quick reference to instrument operation, special functions, and error messages.

Special function key for complete control of Analyzer functions. This key also executes many built-in troubleshooting routines.

If using the 8901B without the 11722A, input circuitry is protected from damage for signals up to 25 watts.

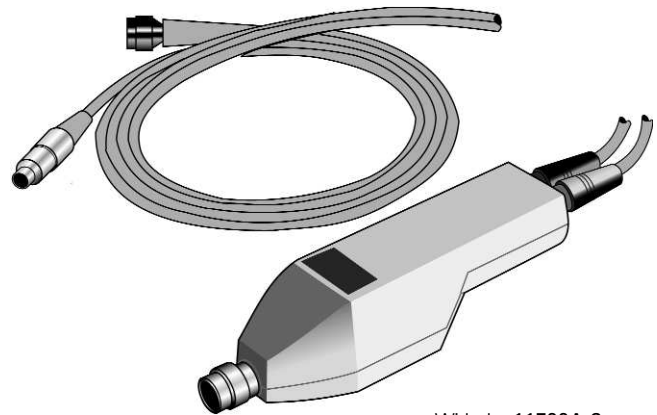

With the 11722A Sensor Module, all measurements including RF Power are made at a single connector.

For Your Applications

Transmitter Testing

You can perform your standard transmitter measurements with the 8901B Modulation Analyzer. It measures transmitter output power very accurately, and it counts frequency to 10 Hz resolution. The 8901B will accurately measure the signal modulation, and characterize the demodulated audio signal's frequency, level, and distortion.

The 8901B includes many features designed for transmitter testing, such as a Peak Hold detector for capturing short transient modulation signals and a special Tone-Burst-Receiver Mode. Using this mode, audio signals are captured and demodulated in <5 msec. This is used for demodulating signalling tones sent when a transmitter is first keyed. Because the 8901B may be directly connected to the output of the transmitter, overpower protection to 25 watts is standard.

RF Signal Characterization

The 8901B Modulation Analyzer is an excellent lab and production tool for accurately characterizing RF signals from 150 kHz to 1300 MHz.

The 8901B's built-in power meter eliminates the need for an external power meter. Unlike diode detectors, the 8901B's power meter accurately measures signals with harmonics and spurious.

Use the 8901B to perform residual AM and FM measurements of such low noise sources as crystal oscillators, or make accurate AM/ ϕ M and AM/AM conversion measurements of phase and amplitude sensitive devices such as bandpass filters and multiple channel receivers. Excellent isolation between AM and FM makes it simple to separate the AM and ϕ M of AM stereo, incidental AM of FM transmitters and the AM, FM and ϕ M components of complex signals.

Automatic Test Systems

The 8901B is an important component of automatic RF test systems. All functions—power measurement, frequency count, modulation, and audio analysis—are fully automatic and easily programmed. With these measurements combined into one instrument, interfacing requirements, hardware costs, and software development time are reduced.

Because of its precision modulation and power measurements, the 8901B is a valuable tool for calibrating automatic test systems.

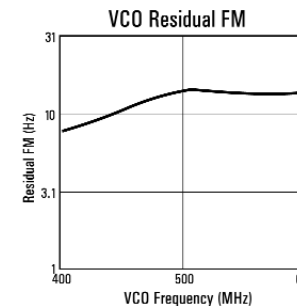
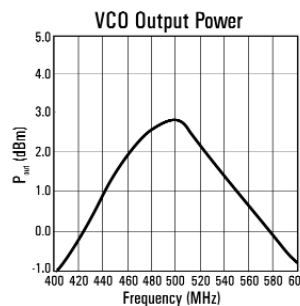
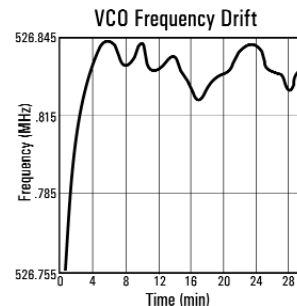
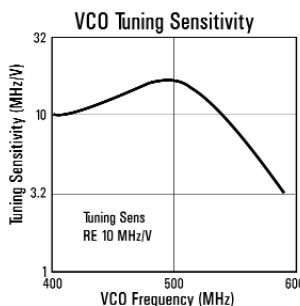

Performance You Need

RF Power: Power Meter Accuracy

The Agilent 8901B Modulation Analyzer performs power measurements with superb accuracy and measurement ease. Power meter linearity is ± 0.02 dB plus ± 0.02 dB per range change. With a single key stroke the 8901B automatically senses the power sensor type, autoranges to the input signal, measures its power, compensates for sensor flatness, and displays the results in units you choose. In addition to the 11722A Sensor Module, the 8901B accepts all 8480 series power sensors for power measurements from -70 dBm (100 pW) to +44 dBm (25W) at frequencies from 100 kHz to 26.5 GHz.

If you change sensors, just enter the new calibration factors into non-volatile memory, either from the keyboard or via GPIB. You can store two complete sets of sensor calibration factors.

The front panel Power Reference enables precise calibration of your power sensor at the reference calibration factor frequency. This 50 MHz reference is set to 1.00 mW $\pm 0.7\%$, traceable to the U.S. National Bureau of Standards.

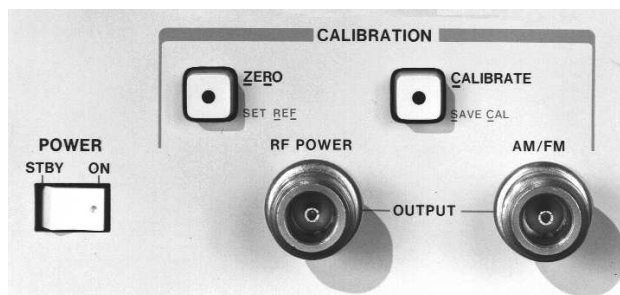

RF Power and AM/FM calibrators

RF Frequency: High Resolution

The 8901B Modulation Analyzer counts all types of modulated signals with 10 Hz resolution. The high stability reference option has an aging rate of less than 1×10^{-9} /day. For selectively counting low level signals, use the 8901B's manual tune mode.

Audio: Built-in Convenience

The 8901B's audio capabilities often eliminate the need for external equipment when measuring demodulated signals or external audio signals. The Analyzer counts audio frequencies with 6 digits of resolution, measures distortion of 400 Hz and 1000 Hz signals and measures rms levels from 100 mV to 3V with 4% accuracy.

AM, FM, and ϕ M: Superb Accuracy

Precise AM, FM, and ϕ M measurements are a major contribution of the 8901B Modulation Analyzer. Basic measurement accuracy is 1% for AM and FM and 3% for ϕ M. With excellent separation between the FM discriminator and AM detector, incidental AM and FM measurements are made easily and accurately.

Residual AM in a 50 Hz to 3 kHz bandwidth is less than 0.01%. The very low noise FM discriminator makes residual FM measurements of less than 1 Hz at 100 MHz increasing linearly with frequency to less than 8 Hz at 1300 MHz.

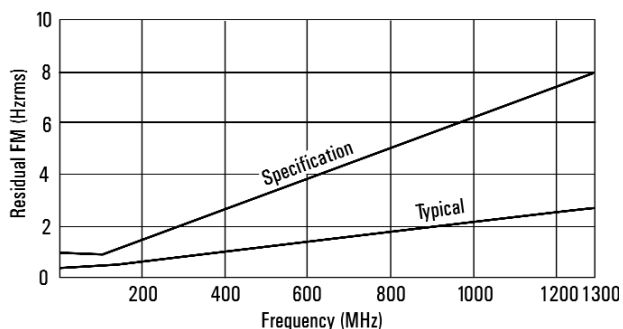

Select from six detectors for modulation measurements. In addition to positive and negative peak detectors, the 8901B provides a \pm Peak/2 detector. For residual noise measurements, choose from an average responding detector which is rms sinewave calibrated or a true rms detector. The Peak Hold detector captures and holds the maximum positive or negative peak modulation of a signal. This is ideal for modulation limiting tests.

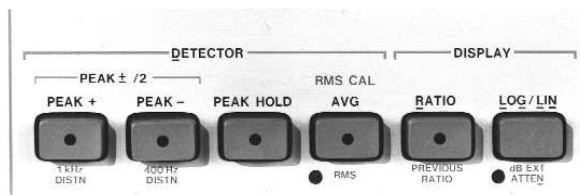

The AM/FM calibrator provides extremely accurate modulated signals with $\pm 0.1\%$ accuracy, for easy self-check and re-calibration of the instrument AM and FM calibration factors.

Features You Want

Single Key Measurements

The 8901B is very easy to use. In automatic operation, all major functions are selected with a single key. No manual tuning or range selection is needed. The front panel is simple, uncluttered, and easy to use.

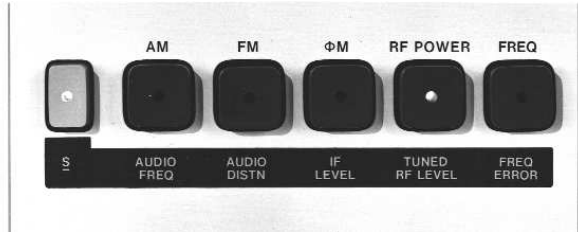

Flexible Display Formats

The 8901B offers numerous data display formats. For example, RF power can be displayed in watts, dBm, volts, dB V, mV, dB mV, μ V, and dB μ V. Use the Ratio and Log/Lin keys to display results in dB or % relative to a measured value or a value entered from the keyboard. These features often eliminate the need for manual calculations.

Selectable Filters

Independently selectable high-pass and low-pass audio filters remove undesired signals such as harmonics, noise, and spurious from the recovered modulation signal. The >20 kHz Bessel filter minimizes overshoot from squarewave modulation. There are also four de-emphasis networks for common FM communication and broadcast applications.

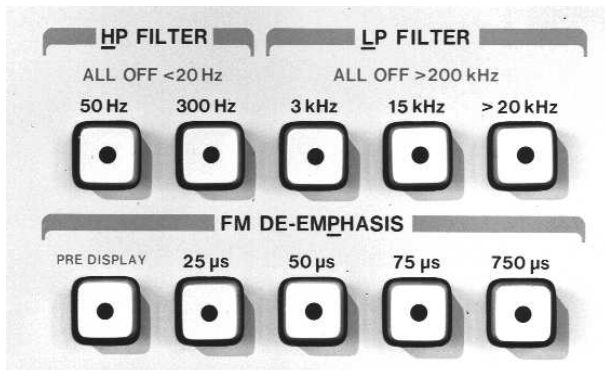

Flexible Tuning Modes

The 8901B Modulation Analyzer is fully automatic. Select the measurement and the 8901B tunes to the largest signal. If selective tuning is needed, enter the approximate frequency on the keyboard. Use Track mode to follow signals which vary in frequency.

Fully Programmable

All 8901B functions are fully programmable via the Interface Bus (GPIB). Programming commands are easy to generate. This ease of use coupled with the multiple functions of the 8901B make it a powerful tool for system applications.

Operation to 26.5 GHz and Beyond

For your measurement needs above 1300 MHz, use the Frequency Offset mode in the system configuration shown. This mode extends the 8901B capabilities to microwave frequencies.

The system functions as a single instrument, making microwave modulation, frequency, and power measurements. You control operation from the 8901B front panel. When the external LO frequency must be changed, the 8901B requests the external controller to make the change. A separate non-volatile cal-factor table is available in Frequency Offset mode for your microwave power sensor. Measurement performance is maintained, except for the increase in residual FM and ϕ M noise due to the external LO.

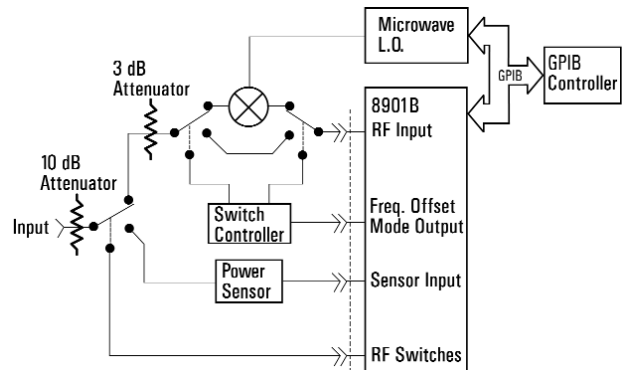

Store and Recall

You can store eight complete front panel settings in non-volatile memory for later recall. With this feature you can quickly change between major measurement settings.

Special Functions

Special functions extend your control over the instrument. Examples of this include selecting frequency count resolution, measuring SINAD, measuring external audio signals and signaling when a measured value exceeds a previously entered limit.

Agilent 11722A Sensor Module

A Single RF Input Connection

With the 11722A Sensor Module, you get all the performance of the Modulation Analyzer, plus superb power measurement accuracy, at a single connector. You can characterize a signal without manually switching between the power sensor and the analyzer's RF input.

Low Input SWR and Insertion Loss

Special care is taken with each sensor module to minimize input SWR and resulting errors. A low SWR attenuator isolates the power sensor from the source under test, reducing mismatch. Microwave hardware and a selected RF input cable further improve SWR and insertion loss.

Zero the Sensor with One Keystroke

You can zero the 11722A power sensor without removing it from the source under test. Just push the 8901B ZERO key. After eight seconds, zeroing is completed and the new zero offsets are stored automatically.

Individually Calibrated

Each 11722A Sensor Module is individually calibrated, traceable to the U.S. National Bureau of Standards. The calibration factors are printed on the sensor module for easy reference. Enter these factors into the 8901B non-volatile memory and the instrument automatically compensates for the power sensor efficiency and mismatch loss at each frequency, interpolating where necessary.



N.B.S. Traceable Calibration Factors

Agilent 8901B Specifications

RF Power

The 8901B Modulation Analyzer, with 11722A Sensor Module, performs RF Power Measurements from -20 dBm ($10 \mu\text{W}$) to $+30$ dBm (1W) at frequencies from 100 kHz to 2.6 GHz. The 8901B can be used with any of the 8480 series power sensors (8481A/1B/1H/2A/2B/2H/3A/4A/5A) to make power measurements from -70 dBm (10pW) to $+44$ dBm (25W) at frequencies from 100 kHz to 26.5 GHz. The 8480 series sensors also work with the 435A and 436A Power Meters. Unless otherwise specified, the specifications shown below refer to the 8901B only.

All parameters describe performance in automatic operation or properly set manual conditions. **Specifications** describes the instrument's warranted performance. **Supplement Characteristics** (*shown in italics*) are intended to provide information useful in applying the instrument by giving typical, but non-warranted, performance parameters.

RF POWER RESOLUTION:¹

0.1% of full scale in watts or volts mode

0.01 dB in dBm or $\text{dB}_{\text{relative}}$ mode

LINEARITY (includes sensor nonlinearity):

RF range linearity \pm RF range-to-range change error

RF RANGE LINEARITY (using Recorder Output):²

± 0.02 dB, RF ranges 2 – 5

± 0.03 dB, RF range 1

Using front-panel display add ± 1 count of least-significant digit.

RF RANGE-TO-RANGE CHANGE ERROR:

± 0.02 dB/RF Range Change from reference range

INPUT SWR: <1.15 , using 11722A Sensor Module

ZERO SET (DIGITAL SETTABILITY OF ZERO):

$\pm 0.07\%$ of full scale of lowest range

Decrease by a factor of 10 for each higher range.

Supplemental Characteristics:

ZERO DRIFT OF METER:

$\pm 0.03\%$ of full scale/ $^{\circ}\text{C}$ of lowest range

NOISE (at constant temperature, peak change over any one-minute interval for the 11722A Sensor Module and 8481A/1B/1H/2A/2B/2H/3A/5A Sensors):

0.4% of full scale on range 1 (lowest range)

0.13% of full scale on range 2

0.013% of full scale on range 3

0.0013% of full scale on range 4

0.00013% of full scale on range 5

For 8484A Sensor multiply noise by five on all ranges.

1. The 8901B fundamental RF Power measurement units are watts. Further internal processing is done on this number to display all other units.
2. When using 8484A sensor the noise specification may mask the linearity specification and become the predominant error. When operating on the top RF power range, add the Power Sensor Linearity percentages found in the power sensor specifications.

ZERO DRIFT OF SENSORS (1 HOUR, AT CONSTANT TEMPERATURE AFTER 24-HOUR WARM-UP):

±0.1% of full scale of lowest range for 11722A Sensor Module and 8481A/1B/1H/2A/2B/2H/3A/5A sensors
 ±2.0% of full scale of lowest range for 8484A sensor
 Decrease by a factor of 10 for each higher range.

RF POWER RANGES OF 8901B MODULATION ANALYZER WITH 11722A SENSOR MODULE:

– 20 dBm to –10 dBm (10 µW to 100 µW), range 1
 – 10 dBm to +0 dBm (100 µW to 1 mW), range 2
 +0 dBm to +10 dBm (1 mW to 10 mW), range 3
 +10 dBm to +20 dBm (10 mW to 100 mW), range 4
 +20 dBm to +30 dBm (100 mW to 1W), range 5

RESPONSE TIME (0 to 99% OF READING):

<10 seconds, range 1
 <1 second, range 2
 <100 milliseconds, ranges 3-5

DISPLAYED UNITS:

watts, dBm, dB_{relative}, %_{relative}, volts, mV, µV, dB V, dB mV, dB µV

INTERNAL NON-VOLATILE CAL-FACTOR TABLES (user-modifiable using special functions):

MAXIMUM NUMBER OF CAL FACTOR/FREQUENCY ENTRIES:

Table #1 (Primary): 16 pairs plus Reference Cal Factor
Table #2 (Frequency Offset): 22 pairs plus Reference Cal Factor

MAXIMUM ALLOWED FREQUENCY ENTRY: 42 GHz

FREQUENCY ENTRY RESOLUTION: 50 kHz

CAL FACTOR RANGE: 40 to 120%

CAI FACTOR RESOLUTION: 0.1%

Power Reference

POWER OUTPUT:

1.00 mW, factory set to ±0.7%, traceable to the U.S. National Bureau of Standards

ACCURACY:

±1.2% worst case (±0.9% rss) for one year (0 °C to 55 °C)

Supplemental Characteristics:

FREQUENCY: 50 MHz nominal

SWR: 1.05 nominal

FRONT PANEL CONNECTOR: Type-N female

3. But not to exceed: 50 Hz to 40 kHz rates for stated accuracy with rms detector.
4. Peak residuals must be accounted for in peak readings.
5. For peak measurements only: AM accuracy may be affected by distortion generated by the Analyzer. In the worst case this distortion can decrease accuracy by 0.1% of reading for each 0.1% of distortion.
6. Flatness is the variation in indicated AM depth for constant depth on input signal.
7. For optimum flatness, cables should be terminated with their characteristic impedance.

Amplitude Modulation

RATES:

20 Hz to 10 kHz, 150 kHz ≤f_c<10 MHz
 20 Hz to 100 kHz, 10 MHz ≤f_c≤1300 MHz

DEPTH: to 99%

ACCURACY:^{3,4,5}

AM Accuracy	Frequency Range	Rates	Depths
±2% of reading ±1 digit	150 kHz to 10 MHz	50 Hz to 10 kHz	5% to 99%
±3% of reading ±1 digit	150 kHz to 10 MHz	20 Hz to 10 kHz	to 99%
±1% of reading ±1 digit	10 MHz to 1300 MHz	50 Hz to 50 kHz	5% to 99%
±3% of reading ±1 digit	10 MHz to 1300 MHz	20 Hz to 100 kHz	to 99%

For rms detector add ±3% of reading.

FLATNESS:^{6,7}

AM Accuracy	Frequency Range	Rates	Depths
±0.3% of reading ±1 digit	10 MHz to 1 300 MHz	90 Hz to 10 kHz	20% to 80%

DEMODULATED OUTPUT DISTORTION:

<0.3% THD for ≤50% depth
 <0.6% THD for ≤95% depth

FM REJECTION (50 Hz TO 3 kHz BW):⁴

FM Rejection	Frequency Range	Rates	Deviations
< 0.2% AM	250 kHz to 10 MHz	400 Hz or 1 kHz	<5 kHz _{peak}
< 0.2% AM	10 MHz to 1300 MHz	400 Hz or 1 kHz	<50 kHz _{peak}

RESIDUAL AM (50 Hz to 3 kHz BW): <0.01%_{rms}

Supplemental Characteristics:

DETECTORS: +peak, -peak, ±peak/2, peak hold, average (rms sinewave calibrated), rms

MAXIMUM DEPTH, RESOLUTION, AND MAXIMUM DEMODULATED OUTPUT SENSITIVITY ACROSS AN OPEN CIRCUIT (600 Ω OUTPUT IMPEDANCE):⁷

Maximum Resolution	Maximum Demodulated Output Sensitivity	Depths
0.1%	0.01 V/percent	AM _{peak} ≥40.0%
0.01%	0.1 V/percent	AM _{peak} <40.0%
0.001% (rms detector only)	0.1 V/percent	AM _{rms} <3.0%

Frequency Modulation

RATES:⁸

20 Hz to 10 kHz, 150 kHz $\leq f_c < 10$ MHz
 20 Hz to 200 kHz, 10 MHz $\leq f_c \leq 1300$ MHz

DEVIATIONS:

40 kHz_{peak} maximum, 150 kHz $\leq f_c < 10$ MHz
 400 kHz_{peak} maximum, 10 MHz $\leq f_c \leq 1300$ MHz

ACCURACY:^{3,4,8}

FM Accuracy	Frequency Range	Rates	Deviations
$\pm 2\%$ of reading ± 1 digit	250 kHz to 10 MHz	20 Hz to 10 kHz	≤ 40 kHz _{peak}
$\pm 1\%$ of reading ± 1 digit	10 MHz to 1300 MHz	50 Hz to 100 kHz	≤ 400 kHz _{peak}
$\pm 5\%$ of reading ± 1 digit	10 MHz to 1300 MHz	20 Hz to 200 kHz	≤ 400 kHz _{peak}

For rms detector add $\pm 3\%$ of reading.

DEMODULATED OUTPUT DISTORTION:^{8,9}

THD	Frequency Range	Rates	Deviations
$< 0.1\%$	400 kHz to 10 MHz	20 Hz to 10 kHz	< 10 kHz
$< 0.1\%$	10 MHz to 1300 MHz	20 Hz to 100 kHz	< 100 kHz

AM REJECTION (50 Hz TO 3 kHz BW):⁴

AM Rejection	Frequency Range	Rates	Depths
< 20 Hz peak deviation	150 kHz to 1300 MHz	400 Hz or 1 kHz	$\leq 50\%$

RESIDUAL FM (50 Hz to 3 kHz BW):

< 8 Hz_{rms} at 1300 MHz, decreasing linearly with frequency to
 < 1 Hz_{rms} for 100 MHz and below

Supplemental Characteristics

MAXIMUM FM DEVIATION, RESOLUTION, AND MAXIMUM DEMODULATED OUTPUT SENSITIVITY ACROSS AN OPEN CIRCUIT (600 Ω OUTPUT IMPEDANCE):⁷

Maximum Resolution	Maximum Demodulated Output Sensitivity	Deviations
100 Hz	0.01 mV/Hz	$\Delta F_{peak} \geq 40$ kHz
10 Hz	0.1 mV/Hz	4.0 kHz $\leq \Delta F_{peak} < 40$ kHz
1 Hz	1.0 mV/Hz	$\Delta F_{peak} < 4$ kHz
0.1 Hz (rms detector only)	1.0 mV/Hz	$\Delta F_{rms} < 0.3$ kHz

Resolution is increased one digit with 750 μ s de-emphasis and pre-display on.

The demodulated output signal present at the Modulation Out/Audio In connector is increased in amplitude by a factor of 10 with 750 ms de-emphasis.

DEMODULATED OUTPUT DISTORTION:

THD	Frequency Range	Rates	Deviations
$< 0.3\%$	150 kHz to 400 kHz	20 Hz to 10 kHz	< 10 kHz

DETECTORS: +peak, -peak, $\pm peak/2$, peak hold, average (rms sinewave calibrated), rms

STEREO SEPARATION (50 Hz to 15 kHz): > 47 dB

Phase Modulation

RATES:

200 Hz to 10 kHz, 150 kHz $\leq f_c < 10$ MHz
 200 Hz to 20 kHz, 10 MHz $\leq f_c \leq 1300$ MHz

ACCURACY:⁴

$\pm 4\%$ of reading ± 1 digit, 150 kHz $\leq f_c < 10$ MHz
 $\pm 3\%$ of reading ± 1 digit, 10 MHz $\leq f_c \leq 1300$ MHz
 For rms detector add $\pm 3\%$ of reading.

DEMODULATED OUTPUT DISTORTION: $< 0.1\%$ THD

AM REJECTION (FOR 50% AM AT 1 kHz RATES):⁴

< 0.03 radians peak (50 Hz to 3 kHz BW)

MAXIMUM DEVIATION, RESOLUTION, AND MAXIMUM DEMODULATED OUTPUT SENSITIVITY ACROSS AN OPEN CIRCUIT (600 Ω OUTPUT IMPEDANCE):⁷

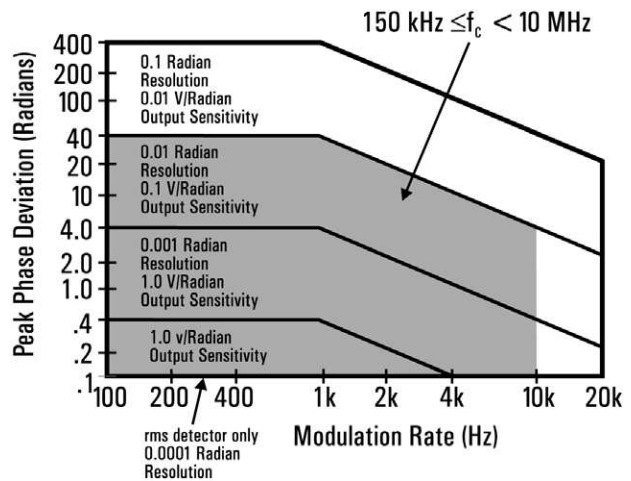

Supplemental Characteristics:

MODULATION RATES: usable from 20 Hz to 100 kHz with degraded performance

DETECTORS: +peak, -peak, $\pm peak/2$, peak hold, average (rms sinewave calibrated), rms

8. But not to exceed: 20 kHz rates and 40 kHz peak-deviations with 750 μ s de-emphasis filter.

9. With 750 μ s de-emphasis and pre-display "off," distortion is not specified for modulation outputs > 4 V peak. This condition can occur near maximum deviation for a measurement range, at rates < 2 kHz.

Modulation Reference

AM CALIBRATOR DEPTH AND ACCURACY:

33.33% depth nominal, internally calibrated to an accuracy of $\pm 0.1\%$

FM CALIBRATOR DEVIATION AND ACCURACY:

34 kHz peak deviation nominal, internally calibrated to an accuracy of $\pm 0.1\%$

Supplemental Characteristics:

CARRIER FREQUENCY: 10.1 MHz

MODULATION RATE: 10 kHz

OUTPUT LEVEL: -25 dBm

Frequency Counter

RANGE: 150 kHz to 1300 MHz

MAXIMUM RESOLUTION: 10 Hz

DEMODULATED OUTPUT DISTORTION: $<0.1\%$ THD

ACCURACY:

± 3 counts of least-significant digit
 \pm Reference accuracy

Supplemental Characteristics:

MODES:

Frequency and Frequency Error (displays the difference between the frequency entered via the keyboard and the actual RF input frequency)

SENSITIVITY IN MANUAL TUNING MODE:

0.22 mV_{rms} (-60 dBm) (Approximate frequency must be entered from keyboard.)

Internal Reference

FREQUENCY: 10 MHz

AGING RATE:

$<1 \times 10^{-6}$ /month
 $<1 \times 10^{-9}$ /day (Option 002)¹⁰

Supplemental Characteristics:

INTERNAL REFERENCE ACCURACY:

Overall accuracy is a function of time base calibration \pm aging rate \pm temperature effects \pm line voltage effects \pm short-term stability.

	Standard	Option 002
Aging Rate	$<1 \times 10^{-6}$ /mo	$<1 \times 10^{-9}$ /day
Temperature Effects	$<2 \times 10^{-7}$ /°C	$<2 \times 1-10^{-10}$ /°C
Line Voltage Effects (+5%, -10% Line Voltage Change)	$<1 \times 10^{-8}$	$<6 \times 10^{-10}$
Short Term Stability	—	$<1 \times 10^{-9}$ for 1s average

Carrier Noise (Options 030-037)

FREQUENCY RANGE: 10 MHz to 1300 MHz

CARRIER POWER RANGE:

+30 dBm to -20 dBm;
 12.5 kHz, 25 kHz, and 30 kHz filters
 +30 dBm to -10 dBm; carrier noise filter

DYNAMIC RANGE: 115 dB

CARRIER REJECTION (temp. ≤ 35 °C):

>90 dB; for offsets of at least 1 channel spacing or 5 kHz, whichever is greater

RELATIVE MEASUREMENT ACCURACY:

± 0.5 dB; levels³ -95 dBc; 12.5 kHz, 25 kHz and 30 kHz filters
 ± 0.5 dB; levels³ -129 dBc/Hz; carrier noise filter

CARRIER NOISE FILTER:

Filter Noise Bandwidth: 2.5 kHz nominal
Noise Bandwidth Correction Accuracy (stored in non-volatile memory): ± 0.2 dB

Supplemental Characteristics:

ADJACENT/ALTERNATE CHANNEL FILTERS:

6 dB Filter Bandwidth:

8.5 kHz, 12.5 kHz adjacent-channel filter
 16.0 kHz, 25 kHz adjacent-channel filter
 30.0 kHz, 30 kHz (cellular radio) alternate-channel filter

TYPICAL NOISE FLOOR: -150 dBc/Hz, 0 dBm carrier power level

For system noise performance add LO contribution.

10. After 30 day warm-up

Audio Frequency Counter

FREQUENCY RANGE:

20 Hz to 250 kHz (*Usable to 600 kHz*)

MAXIMUM EXTERNAL INPUT VOLTAGE: 3 V_{rms}

Accuracy (For Demodulated Signals):¹¹

Accuracy	Frequency	Modulation (Peak)
±3 counts of least significant digit ±Internal Reference Accuracy	>1 kHz	AM ≥10% FM ≥1.0 kHz φM ≥1.5 radians
±0.02 Hz ±Internal Reference Accuracy	≤1 kHz	AM ≥10% FM ≥1.0 kHz φM ≥1.5 radians
±0.2 Hz ±Internal Reference Accuracy (3 kHz low-pass filter inserted)	≤3 kHz	1.5% ≤ AM <10% 0.15 kHz ≤ FM <1.0 kHz 0.15 radian ≤ φM <1.5 radians

Accuracy (For External Signals):¹¹

Accuracy	Frequency	Level
±3 counts of least-significant digit ±Internal Reference	>1 kHz	≥100 mV _{rms}
±0.02 Hz ±Internal Reference Accuracy	≤1 kHz	≥100 mV _{rms}

Supplemental Characteristics:

DISPLAYED RESOLUTION: 6 digits

MEASUREMENT RATE: 2 reading/s

COUNTING TECHNIQUE:

Reciprocal with internal 10 MHz time base

AUDIO INPUT IMPEDANCE: 100 kΩ nominal

Audio Distortion

FUNDAMENTAL FREQUENCIES:

400 Hz ± 5% and 1 kHz ±5%

MAXIMUM EXTERNAL INPUT VOLTAGE: 3 V

DISPLAY RANGE:

0.01% to 100.0% (–80.00 dB to 0.00 dB)

DISPLAYED RESOLUTION: 0.01% or 0.01 dB

ACCURACY: ±1 dB of reading

SENSITIVITY:

Modulation: 0.15 kHz peak FM, 1.5% peak AM or 0.6 radian peak φM

External: 100 mV_{rms}

RESIDUAL NOISE AND DISTORTION:¹²

0.3% (–50 dB), temperature <40 °C

Supplemental Characteristics:

MEASUREMENT 3 dB BANDWIDTH: 20 Hz to 50 kHz

DETECTION: True rms

MEASUREMENT RATE: 1 reading/s

AUDIO INPUT IMPEDANCE: 100 kΩ nominal

Audio RMS Level

FREQUENCY RANGE: 50 Hz to 40 kHz

VOLTAGE RANGE: 100 mV to 3V

ACCURACY: ± 4.0% of reading

Supplemental Characteristics:

FULL RANGE DISPLAY: .3000V, 4.000.

AC CONVERTER: true-rms responding for signals with crest factor of ≤3

MEASUREMENT RATE: 2 readings/s

AUDIO INPUT IMPEDANCE: 100 kΩ nominal

Audio Filters

DE-EMPHASIS FILTERS: 25 μs, 50 μs, 75 μs, and 750 μs. De-emphasis filters are single-pole, low-pass filters with 3 dB frequencies of: 6366 Hz for 25 μs, 3183 Hz for 50 μs, 2122 Hz for 75 μs, and 212 Hz for 750 μs.

50 Hz HIGH-PASS FILTER (2 POLE):

Flatness: <1% at rates ≥200 Hz

300 Hz HIGH-PASS FILTER (2 POLE):

Flatness: <1% at rates ≥1 kHz

3 kHz LOW-PASS FILTER (5 POLE):

Flatness: <1% at rates ≤1 kHz

15 kHz LOW-PASS FILTER (5 POLE):

Flatness: <1% at rates ≤10 kHz

>20 kHz LOW-PASS FILTER (9 POLE BESSEL):¹³

Flatness: <1% at rates ≤10 kHz

Supplemental Characteristics:

DE-EMPHASIS FILTER TIME CONSTANT ACCURACY: ±3%

HIGH PASS AND LOW PASS FILTER: 3 dB

FREQUENCY ACCURACY: ±3%

>20 kHz LOW PASS FILTER: 3 dB Cutoff Frequency:

100 kHz nominal

OVERSHOOT ON SQUARE WAVE MODULATION:¹³ <1%

11. With the low-pass and high-pass audio filters used to stabilize frequency readings.

12. For demodulated signals, the residual noise generated by the 8901B must be accounted for in distortion measurements. (that is residual AM, FM or φM.)

13. The >20 kHz low-pass filter is intended for minimum overshoot with square-wave modulation.

RF Input

FREQUENCY RANGE: 150 kHz to 1300 MHz

OPERATING LEVEL:

Minimum Operating Level	Maximum Operating Level	Frequency Range
12 mV _{rms} (-25 dBm)	7 V _{rms} (1 W _{peak}) Source SWR <4	150 kHz to 650 MHz
22 mV _{rms} (-20 dBm)	7 V _{rms} (1 W _{peak}) Source SWR <4	650 MHz to 1300 MHz

Supplemental Characteristics:

TUNING:

Normal Mode: Automatic and Manual frequency entry

Track Mode: Automatic and Manual frequency entry, $f_c \geq 10$ MHz

Acquisition Time (Automatic Operation): ~1.5 s

INPUT IMPEDANCE: 50 Ω nominal

MAXIMUM SAFE DC INPUT LEVEL: 5 V

General Specifications

TEMPERATURE: Operating: 0 °C to 55 °C
Storage: -55 °C to 75 °C

REMOTE OPERATION: GPIB; all functions except the line switch are remotely controllable.

GPIB COMPATIBILITY: (Defined in IEEE 488-1978) SH1, AH1, T5, TE0, L3, LE0, SR1, RL1, PP0, DC1, DT1, C0, E1

EMI: Conducted and radiated interference is within the requirements of VDE 0871 (Level B), and CISPR publication 11.

POWER: 200 VA maximum; 100, 120, 220, or 240 V (+5% to 10%); 48-66 Hz

WEIGHT: Net 23.4 kg. (51.5 lb.); Shipping 31.1 kg. (68.5 lb.)

DIMENSIONS:

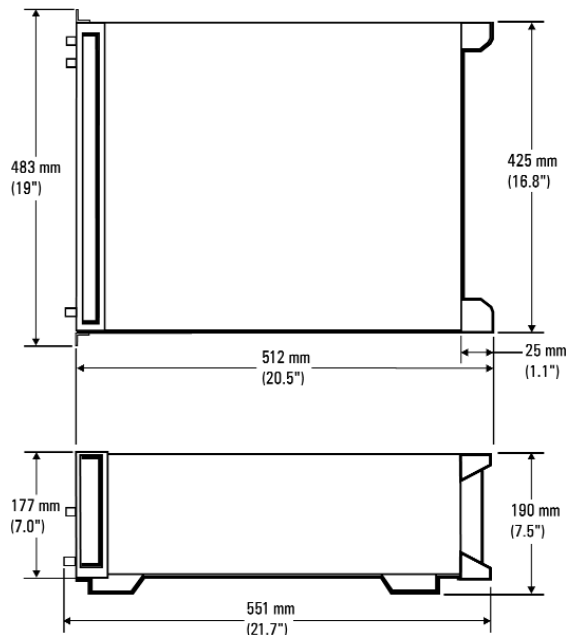

Agilent 11722A Sensor Module

FREQUENCY RANGE: 100 kHz to 2.6 GHz

POWER RANGE: +30 dBm (1 watt) to -20 dBm (10 μ W)

INPUT SWR (CONNECTED TO AN 8901B):
<1.15, for RF Power Measurements

POWER SENSOR LINEARITY:

+2%, -4%; +30 dBm to +20 dBm

Negligible deviation, levels <+20 dBm

CALIBRATION FACTORS:

Each 11722A Sensor Module is individually calibrated. The calibration factors are printed on the 11722A Sensor Module for easy reference.

CAL FACTOR UNCERTAINTY:

Frequency	RSS Uncertainty	Worst Case Uncertainty
0.1 MHz	0.7 %	1.6%
0.3 MHz	0.7%	1.6%
1.0 MHz	0.8%	1.7%
3.0 MHz	0.8%	1.7%
10.0 MHz	0.9%	2.0%
30.0 MHz	0.9%	2.0%
50.0 MHz	0.0% (ref)	0.0% (ref)
100.0 MHz	1.1%	2.2%
300.0 MHz	1.1%	2.2%
1000.0 MHz	1.1%	2.2%
2600.0 MHz	1.2%	2.3%

Supplemental Characteristics:

MAXIMUM PEAK POWER:

100 W_{peak} or 300 W μ s per pulse

INPUT IMPEDANCE: 50 Ω nominal

INPUT CONNECTOR: Type N male

SWITCH LIFE: >1,000,000 switchings

SWITCH Isolation: >90 dB

WEIGHT:

Net 0.8 kg. (1.75 lb.); Shipping 1.2 kg. (2.6 lb.); Gross without manual 1050g

DIMENSIONS:

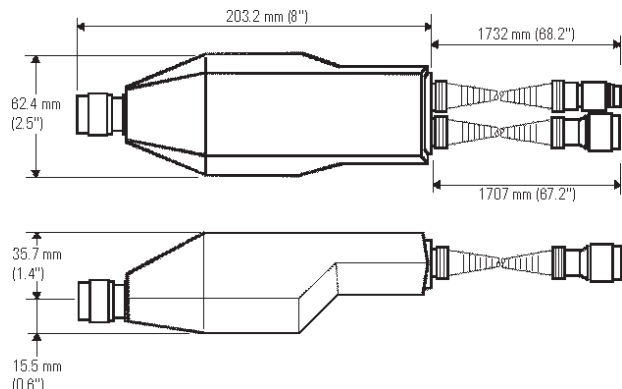

8901B Rear Panel Inputs/Outputs

Supplemental Characteristics:

FM OUTPUT:

10 k Ω impedance, -9 V to 6 V into an open circuit: ~6 V/MHz, dc coupled, 16 kHz bandwidth (one pole)

AM OUTPUT:

10 k Ω impedance, -4 V to 0 V into an open circuit, ~8 mV/%, dc coupled, 16 kHz bandwidth (one pole)

RECORDER OUTPUT:

DC voltage proportional to the measured result, 1 k Ω impedance, 0 V to 4 V for each resolution range, into an open circuit

IF OUTPUT:

50 Ω impedance, 150 kHz to 2.5 MHz, -27 dBm to -3 dBm

10 MHz REFERENCE OUTPUT:

50 Ω impedance, TTL levels (0 V to >2.2 V into an open circuit), available only with Option 002 1 \times 10⁻⁹/day internal reference, outputs internal reference only.

10 MHz REFERENCE INPUT:¹⁴

>500 Ω impedance, 0.5 V_{peak-to-peak} minimum input level

LO INPUT (Option 003):

50 Ω impedance, ~1.27 MHz to 1301.5 MHz, 0 dBm

RF SWITCH REMOTE CONTROL OUTPUT:

Provides output signals to remotely control either an 33311B Option 011 or an 8761A RF switch.

FREQUENCY OFFSET MODE REMOTE CONTROL OUTPUT:

TTL high output if in frequency offset mode (Special Function 27.1 or 27.3) with an external L.O. frequency >0, TTL low output for all other cases

14. External reference accuracy affects accuracy of all measurements.

Ordering Information

8901B Modulation Analyzer

Option 001: Rear panel instead of front panel connections for input, modulation output, and calibrators

Option 002: 1 \times 10⁻⁹/day internal reference oscillator

Option 003: Rear panel instead of front panel connections which allows use with an external local oscillator

Option 004: Operation from 48 Hz to 400 Hz power line (Temp. <400C)

Option 021: Add 11722A Sensor Module

Option 030: High selectivity. Option 030 includes rear-panel external local oscillator connections. 8902A Option 003, rear-panel external local oscillator connections may not be ordered with 8902A Option 030. Two filter options (032 through 037) must be selected with Option 030.

Option 032: 12.5 kHz adjacent channel filter

Option 033: 25 kHz adjacent channel filter

Option 035: 30 kHz (cellular radio) alternate channel filter

Option 037: Carrier noise filter (2 kHz band pass filter)

Option 907: Front panel handle kit

Option 908: Rack mounting flange kit

Option 909: Front panel handle plus rack mounting flange kit

Option 910: Extra manuals

11722A Sensor Module

Option 910: Extra manual

By internet, phone, or fax, get assistance with all your test and measurement needs.

Online Assistance

www.agilent.com/find/assist

Product specifications and descriptions in this document subject to change without notice.

Copyright © 1997, 2000 Agilent Technologies
Printed in U.S.A. 9/00
5980-2699EN



Agilent Technologies

Innovating the HP Way