

Agilent Technologies Emulation and Analysis Solutions for the Motorola M-CORE Series Microprocessors

Product Overview

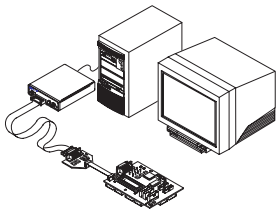

JTAG Emulation

- Verify Interrupt Routines
- Debug Assembly Code
- Optimize Code

Emulation and Analysis Solutions for the Design Team

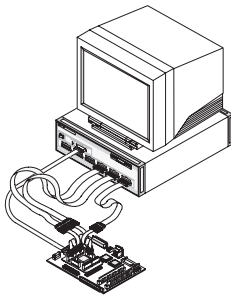

Emulation Solution with Real-Time Trace

- Debug Hardware/Software Interaction
- Profile Hardware/Software Interaction
- Optimize System Performance
- Perform System Test

Debug and Integrate Real-Time Embedded Systems

Quickly and accurately determine the root cause of your team's most difficult hardware, software, and system integration problems with Agilent Technologies' powerful emulation and logic analysis solutions.

Agilent's emulation and analysis solutions for the Motorola M-CORE combine the powerful tools of run control, code download, debugger

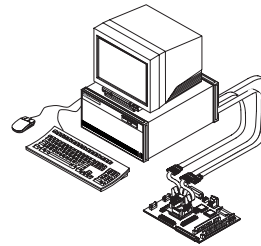

Logic Analysis Solution

- Perform Basic Signal Measurements
- Profile Hardware Operation
- Verify Signal Integrity
- Verify Conformance to Specifications
- Exercise Microprocessor and Other Hardware
- Debug Boot Code

solutions are designed to meet your needs today and protect your investment as your needs change in the future.

With logic analysis providing timing and state analysis, you can monitor microprocessor activity in relation to other important system signals such as a CAN bus, other microprocessors, I/O devices or ATM and Ethernet ports.. Traditional emulation systems don't allow you to time-correlate events across your entire system using timing, analog, and state analysis for your most difficult integration problems.

connections, and logic analysis for a complete, scalable system debug environment.

With a scalable solution from Agilent, design team members can customize Agilent's product offerings to meet their unique requirements. Solutions range from emulation probes combined with the industry's leading debuggers to emulation with real-time trace to solve today's most complex design problems. Agilent's

The logic analyzer is nonintrusive, allowing you to run your target system at full speed. A system trace, up to 32 M deep, can be combined with complex triggering to find the toughest problems. The microprocessor instruction set execution can be correlated to high-level source code with the Agilent source correlation tool set. Emulation and logic analysis solutions are scalable for each member of the digital design team.



Agilent Technologies
Innovating the HP Way

Agilent Technologies Scalable Solutions

The following are three typical configurations for firmware/software debug, hardware debug, and system integration. Components of these solutions include a logic analyzer,

emulation probe/module, analysis probe, inverse assembler, source correlation tool set, and system performance analysis tool set.

Information on each of these components is included in this document.

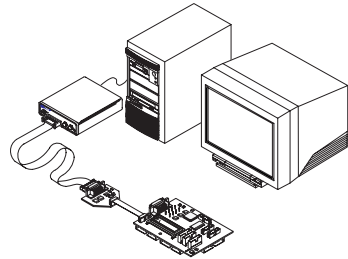

System Features

JTAG Emulation

- Microprocessor run control on your target system
- Debugger connection

System Components and Functionality

- Emulation Probe: (see p. 3)
 - Download code, view and modify memory, and view registers on your target system or evaluation board from the debugger interface
- Connection to industry-leading debuggers from Microtec, Green Hills, and SDS

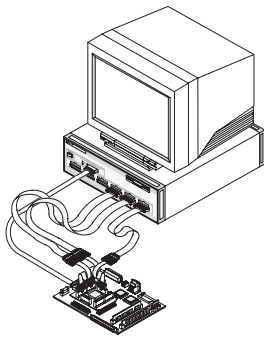

Emulation Solution with Real-Time Trace

- Microprocessor run control on your target system
- Debugger connection
- Real-time logic analysis trace solution:
 - Assembly level trace
 - Source code trace

- 16700 Series Logic Analysis System:
 - Capture and analyze code flow and data flow without halting the target system
 - Time-correlate analog, timing, and state events across your entire system
 - Monitor microprocessor activity in relation to system buses, other microprocessors, or I/O devices
- Inverse Assembler: (see p. 8)
 - Connect to target using AMP Mictor connectors
 - Disassemble trace listing into M-CORE mnemonics
- Integrated Emulation Module: (see p. 3)
 - Download code, view and modify memory, and view registers on your target system or evaluation board from the debugger interface
 - Connect to industry-leading debuggers from Microtec and SDS
- Source Correlation Tool Set: (see p. 9)
 - Time-correlate acquired logic analysis trace to high-level source code
 - Step through in assembly or high-level code

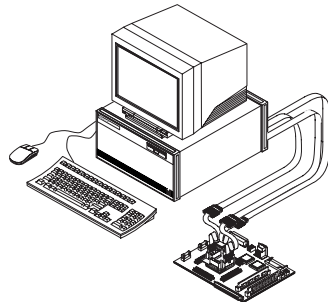

Logic Analysis Solution

- Real-time logic analysis trace solution:
 - Assembly level trace

- 16700 Series Logic Analysis System:
 - Capture and analyze code flow and data flow without halting the target system
 - Time-correlate analog, timing, and state events across your entire system
 - Monitor microprocessor activity in relation to system buses, other microprocessors, or I/O devices
- Inverse Assembler: (see p. 8)
 - Connect to target using AMP Mictor connectors
 - Disassemble trace listing into M-CORE mnemonics

Microprocessor	Package Type	Microprocessor Clock Speed	JTAG Emulation	Emulation Solution with Real-Time Trace	Logic Analysis Solution
M-CORE	any	any	X		
RIM Memory Controller	any	Up to 40 MHZ	X	X	X
REV 1.5 bondout	any	any	X		
MMC 2001	any	any	X		

Table 1: Emulation and Analysis Solutions for M-CORE Microprocessors

Emulation Probe and Module

The emulation probe and module provide the same functionality. The emulation probe is a standalone product, as shown in figure 1. The emulation module is an integrated plug-in for the 16700 Series logic analysis systems.

Both help you debug your code by providing run control, code download, and memory/register display and modification. You can control program execution through single stepping, run/break, and set/modify breakpoints. You can also run code at full speed in the target.

The emulation probe can be controlled by an industry-leading debugger. The emulation module can be controlled by either a debugger or the emulation control interface provided with the logic analyzer. These interfaces are described on page 4.

The Agilent emulation probe and module can be controlled over your local area network (LAN) by the debugger and connect to your target through a 16-pin Berg style connector, as shown in figure 3.

Unlike traditional emulators, the emulation probes and modules provide more stable operation by accessing only the debug pins of the microprocessor. You don't need a serial port on your target system to download code. Unlike ROM monitors, they don't require user memory.

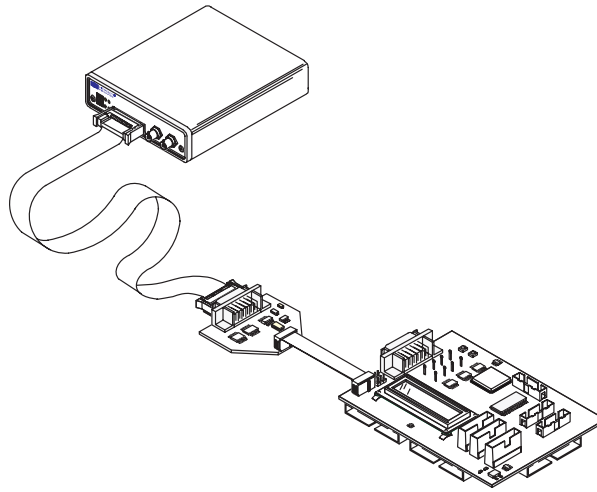

Figure 1: Standalone Agilent Technologies Emulation Probe

Debugger Interface

Industry-leading debuggers can control the Agilent emulation probe and module. You can set breakpoints, single-step through code, examine variables, and modify source code variables from the high-level source code debugger interface.

Debugger interfaces must be ordered directly from the debugger vendor.

Debugger Connections

Green Hills Software, Inc.
30 West Sola Street
Santa Barbara, CA 93101 USA
Phone: (805) 965-6343
<http://www.ghs.com>

Diab-SDS
323 Vintage Park Drive
Foster City, CA 94404 USA
Phone: (650) 356-5400
Fax: (650) 356-5490
<http://www.diabsds.com>

Please check with your local Agilent Technologies Sales Office or visit our web site at:
<http://www.agilent.com/find/las-data>
for the current list of debugger connections.

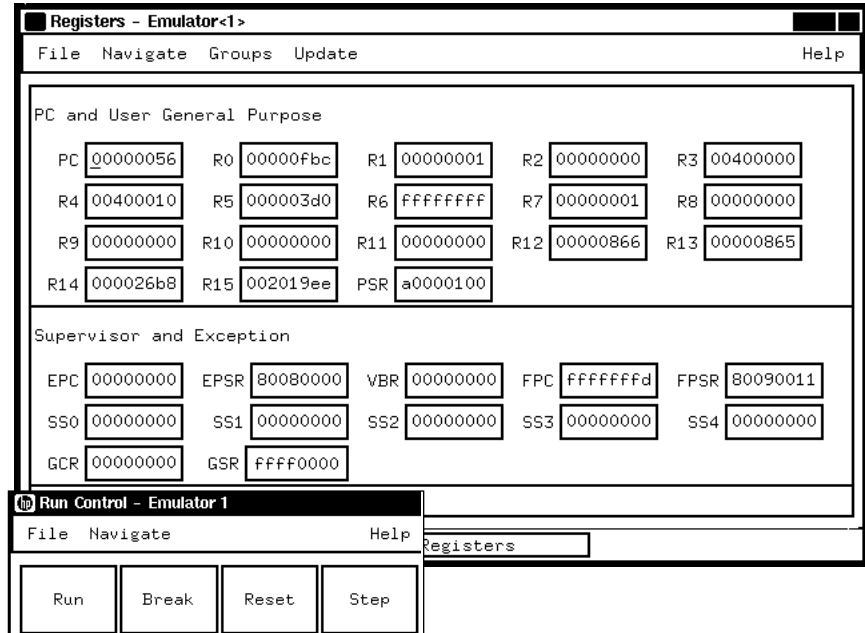

Figure 2: Emulation Control Interface and Registers

Emulation Control Interface

The emulation module integrated into the logic analysis system can be controlled directly by the emulation control interface. You can easily display and modify contents of microprocessor registers, system memory, and I/O. You can also view memory code segments disassembled into familiar M-CORE assembly instructions.

From the run control window you can instruct the microprocessor to run, break, reset, or single-step. You also can choose whether the memory, I/O, and register displays are updated for breaks and single steps.

Writing command files that set up registers, memory, and I/O in your system is easy with the command language. Once the command file is written, save it on the logic analyzer hard disk. When you want to initialize your hardware system to a particular state, simply recall and execute the command file. Unlike a debugger interface, the emulation control interface does not reference back to the high-level source code.

Emulation Module and Probe Migration

Agilent Technologies protects your current investment by providing a migration path for the emulation modules and probes as your needs change. To move from one processor family to another, simply order a migration kit for the emulation module or probe, which will provide all the necessary hardware, firmware, and cables to support your new processor family at a fraction of the cost of a new system.

This same migration path works for the emulation probes or emulation modules.

Emulation Module Triggering Integration with Logic Analyzer

With the emulation module, use the powerful triggering of the Agilent Technologies 16700 Series logic analysis systems to halt on events such as microprocessor activity, system buses, or other external events. The emulation module also can trigger the logic analyzer when a breakpoint is hit. This provides powerful event correlation between the debugger interface environment and the logic analyzer.

Specification	Description
Microprocessors Supported	Motorola M-CORE
External Bus Speed	40 MHz
Physical Connections	Ethernet 10base2 or 10baseT Ethernet connections RS-232-C 1200 through 115 Kbaud rates supported
Number of Breakpoints	Virtually unlimited software breakpoints or one hardware breakpoint
Physical Size	155 mm width x 161 mm depth x 65 mm height
Environmental	
Temperature	Operating: 5 °C to +40 °C (+41 °F to +104 °F) Nonoperating: -40 °C to +70 °C (-40 °F to +158 °F)
Altitude	Operating: 4,600 m (15,000 ft) Nonoperating: 4,600 m (15,000 ft)
Humidity	15% to 80% @ 40 °C for 24 hours
Regulatory Compliance	EMC CISPR 11:1990/EN 55011:1991 Group 1, Class A IEC 801-2:1991/EN 50082-1:1992 4 kV CD, 8 kV AD IEC 801-3:1984/EN 50082-1:1992 3 V/m, (1 kHz 80% AM, 27-1 kHz) IEC 801-4: 1988 / EN 50082-1:1992 0.RkV Sig lines, 1 kV Power lines
Safety Approvals	IEC 1010-1:1990 AMD 1:1992 UL 1244 CSA-C22.2 No. 231

Table 2: Agilent Technologies Emulation Probe and Module Specifications

Emulation Probe and Module Target Connection Information

A 14-pin male 2X7 header Berg style connector is needed on the target development board to connect the M-CORE micro-processor interface assembly to the JTAG debug port of the microprocessor.

The header should be placed as close as possible to the processor to ensure signal integrity. TD0, TD1, TCK, TMS, and /TRST signal traces between the JTAG connector and the M-CORE must be less than three inches. If these signals are connected to other nodes, you must connect in a daisy chain between the JTAG debug connector and the M-CORE. These signals are sensitive to crosstalk and cannot be routed next to active signals, such as clock lines on the target board.

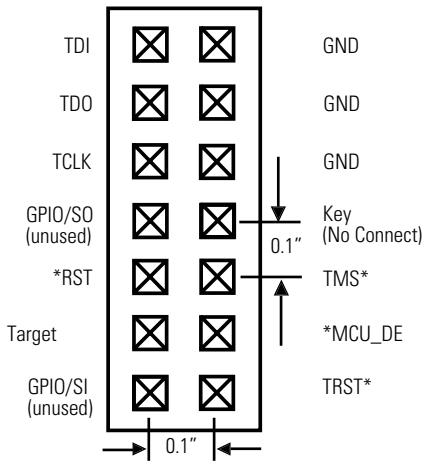

Figure 3. Motorola M-CORE JTAG Connector Information

1. *TDI, TCLK, GPIO/SI, GPIO/SO, TMS*, TRST*, and /RST all need a 10KΩ pullup resistor to VDD.*
2. *Agilent drives /RST open collector.*

Real-Time Trace Analysis

Real-time trace analysis consists of a physical connection to signals on the Motorola M-CORE microprocessors, acquisition of relevant data, and analysis of the real-time captured bus information. Physical connection to the micro-

processor is provided by an AMP Mictor probing solution.

The real-time trace analysis solutions for the Motorola M-CORE include inverse assembly, source correlation, and system performance analysis. For information on the data acquisi-

tion modules for the Agilent 16700 Series logic analysis systems please refer to related Agilent Technologies literature on page 12.

M-CORE Microprocessor	Supported Speed	Probing Solutions	Real-Time Trace Solutions
RIM memory controller based device	Up to 40 MHz	Mictor Connector Probing Solution: <ul style="list-style-type: none"> • Mictor connectors designed in target for access to critical signals for logic analysis 	Inverse Assembly: <ul style="list-style-type: none"> • Disassembly of bus information into M-CORE microprocessor mnemonics • M-CORE configuration files for logic analyzer <hr/> Source Correlation: <ul style="list-style-type: none"> • Time-correlation of acquired trace to high-level source code • Trigger and search through trace in high-level source code <hr/> System Performance Analysis: <ul style="list-style-type: none"> • Statistical performance measurements on trace data • State overview, state interval, time interval, and time overview measurements

Table 3: Real-Time Trace and Probing Alternatives

Supported Memory Controllers	Un-Supported Memory Controllers
<ul style="list-style-type: none"> • RIM Memory Controller 	<ul style="list-style-type: none"> • RISC-Local Bus • EIM Memory Controller

Inverse Assembler

The inverse assembler quickly configures the logic analyzer by labeling address, data, and status signals for the M-CORE microprocessors. It also provides M-CORE mnemonics in the trace listing for easy correlation between captured data and target code. The inverse assembler works with the Agilent B4620B source correlation tool set to provide time correlation between the assembly-level trace and the high-level source code.

The inverse assembler provides filters and color coding to show and/or suppress different instructions such as data reads, data writes, unexecuted prefetches, and memory map regions.

The inverse assembler has several modes of operation, depending on your microprocessor configuration. The inverse assembler provides M-CORE mnemonics, but the cache must be off to see all cycles on the microprocessor.

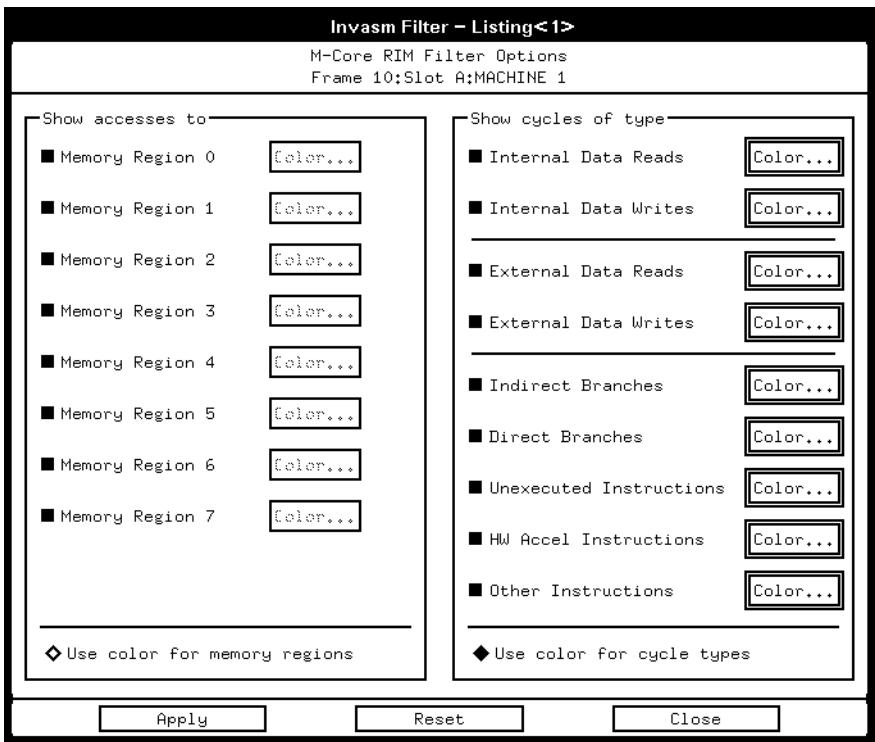

Figure 4: Inverse Assembler Filter

Modes of Operation

State Modes

In state-per-address or mode, the logic analyzer only records those states in which the #SHS signal is toggling.

Timing Mode

Timing analysis is supported. All processor signals are connected directly to the logic analyzer pods.

Agilent Technologies Logic Analyzers Supported

- Contact your Agilent field engineer for latest logic analyzer information

Agilent Technologies B4620B Source Correlation Tool Set

The inverse assembler can be used with the Agilent B4620B source correlation tool set for the Agilent 16700 Series logic analysis systems. This allows time correlation of an acquired trace to source code. The source correlation tool set uses the symbolic information provided in your object file to build a database of source files, line numbers and symbol information.

Once the logic analyzer acquires the real-time trace, you can step through the trace at assembly-code level or source-code level. You can also easily locate the cause of a problem by stepping backward to the root cause. With time-correlated analysis in both the digital and analog domains, Agilent provides powerful solutions for your most difficult hardware/software integration problems.

IEEE 695, Elf/Dwarf, and ASCII symbol files are supported.

System Correlation

With the Agilent logic analysis systems, you can time-correlate bus information from other microprocessors or bus interfaces in your target system, such as a CAN bus, with the M-CORE. Analysis probes are available for additional microprocessors. (Contact your local Agilent Sales Office or visit our web site at: <http://www.agilent.com/find/las-data> for more information).

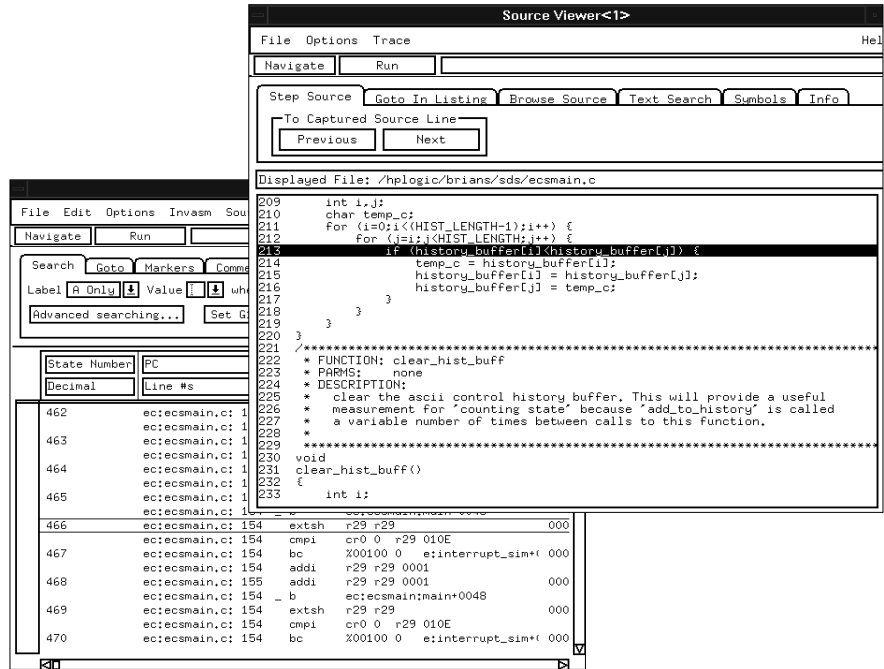

Figure 5: Inverse Assembled Trace Time-Correlated to Source Code Using the Agilent Source Correlation Tool Set

Agilent Technologies B4600B System Performance Analysis Tool Set

The system performance analysis (SPA) tool set is an optional software package for the Agilent 16700 Series logic analysis systems. The SPA tool set provides such statistical performance measurements as state overview, state interval, time

interval, and time overview. The same symbol file used with the source correlation tool set provides symbolic support for the system performance analyzer, as shown in figure 6.

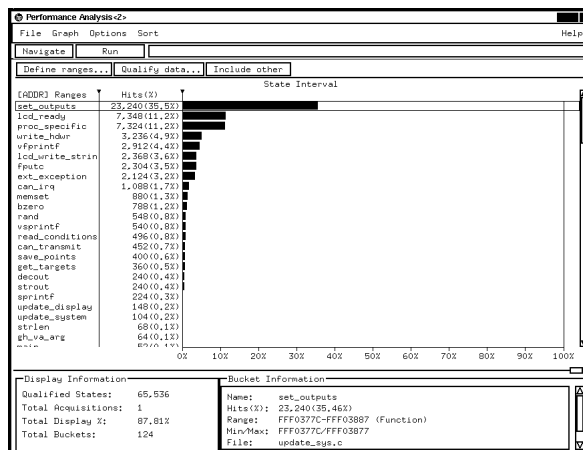

Figure 6: Statistical Performance Information from the Agilent Technologies System Performance Analysis Tool Set

AMP Mictor Connector Probing Solution

Signals required for inverse assembly must be routed to a minimum of four AMP Mictor 38 connectors for connection to the logic analyzer. The AMP Mictor connectors use a minimal amount of board space and provide a convenient connection for real-time trace analysis. Additional Mictor connectors can be used to probe other signals of interest.

Eight, 16-channel logic analyzer pods are required for inverse assembly. These eight pods are connected to four Agilent E5346A high-density termination adapters not included with the inverse assembler. The termination networks are located in the probe tip of the Agilent E5346A for easy application and use. A schematic of this termination is shown in figure 7.

An Agilent support shroud is also recommended to provide additional strain relief between the Agilent E5346A adapter and the AMP Mictor connector. Five shrouds are included with five AMP Mictor connectors in the Agilent E5346-68701 Mictor connector kit. The AMP Mictor connectors are also available from AMP (P/N 2-767004-2).

Probe Loading

- 10 pF on all signals
- 100 Kohms on all signals

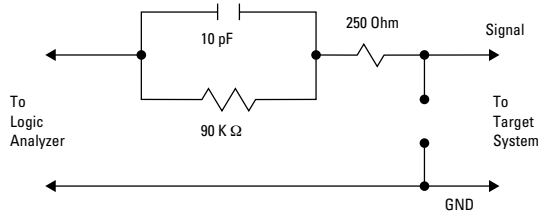

Figure 7: RC Network for Signal Termination

When locating each Mictor connector on your board, try to minimize the trace lengths of signals routed to the Mictor connectors. This will prevent reflections from the long traces and stubs.

For more detailed connection information, including pin-out, please refer to the product note, *Passively Probing a Motorola M-CORE Target System with E5346A High-Density Termination Adapters* (5968-2503E).

System Configuration and Ordering Information

The table below shows the system components you need to order and what is included in each. The solution product numbers do not include

logic analysis. The Agilent 16700 Series logic analysis systems must be ordered separately.

If you want to configure or upgrade your system with individual products, see page 12 for individual product number information.

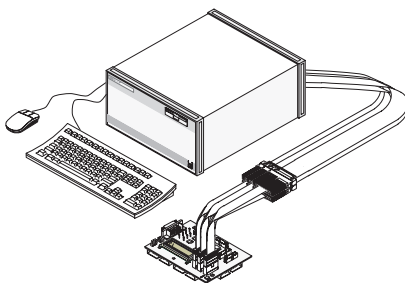
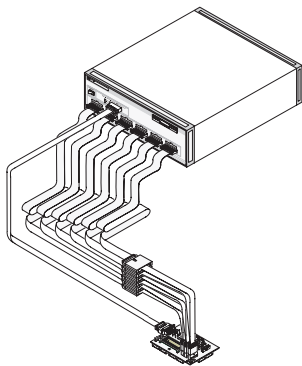
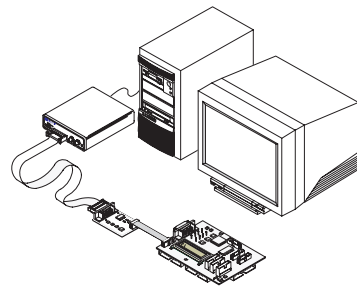

Solution	Products to Order	Included Components
JTAG Emulation		
<ul style="list-style-type: none"> M-CORE Emulation Probe Debugger Connection 	<ul style="list-style-type: none"> Agilent E5900A #090 Order directly from Green Hills, Microtec, or SDS 	
Emulation Solution with Real-Time Trace		
<ul style="list-style-type: none"> Agilent 16700 Series Logic Analysis System Emulation Using Mictor Probing Debugger Connection Optional System Performance Analysis Tool Set 	<ul style="list-style-type: none"> Refer to Agilent publication number 5968-9661E for logic analyzer configuration Contact your Agilent field engineer for latest logic analyzer information Agilent E9512A #001 Four Agilent E5346A High-Density Termination Adapters Agilent E5346-68701 Mictor Connector Kit Order directly from Green Hills, Microtec, or SDS Agilent B4600B 	<ul style="list-style-type: none"> Inverse Assembler-RIM only Source Correlation Tool Set Emulation Module
Logic Analysis Solution		
<ul style="list-style-type: none"> Agilent 16700 Series Logic Analysis System Logic Analysis Solution Using Mictor Probing Optional Source Correlation Tool Set Optional System Performance Analysis Tool Set Optional Emulation Module 	<ul style="list-style-type: none"> Refer to Agilent publication number 5968-9661E for logic analyzer configuration Contact your Agilent field engineer for latest logic analyzer information Agilent E9612A #001 Four Agilent E5346A High-Density Termination Adapters Agilent E5346-68701 Mictor Connector Kit Agilent B4620B Agilent B4600B Agilent E5901A #090 	<ul style="list-style-type: none"> Inverse Assembler-RIM only

Individual Components Ordering Information

Description	Agilent Product
Emulation Probe	E5900A #090
Emulation Module	E5901A #090
Inverse Assembler	E9612A #001
Emulation Module and Emulation Probe Migration	E5902A #090
Source Correlation Tool Set	B4620B
System Performance Analysis Tool Set	B4600B
High-Density Termination Adapter	E5346A
Mictor Connector Kit	E5346-68701

Training and Consulting

Agilent Technologies has experienced Digital Systems Consultants who can help you maximize the utilization of your emulation and analysis system through training and consulting. Digital Systems Consultants are peaked in debugging complex digital hardware/software problems and hardware/software integration.

Agilent training may be delivered through scheduled courses, on-site classes, or one-on-one consulting. Agilent has courses for the beginner as well as advanced users migrating from the 16500 Series system. Call 1-800-593-6632 in the U.S. for information about training schedules and location or to register. For training offered in other geographies and languages, consult the Agilent Technologies Test and Measurement education web site: <http://www.agilent.com/find/tmeducation>.

For consulting services, contact your local Agilent sales office. An Agilent Digital Systems Consultant can help you solve tough digital debug problems by showing you how to apply Agilent tools and debug best practices. Topics covered can include:

- System Installation
- Complex Triggering
- Multiple Bus Analysis
- Source-Line Referencing
- System Performance Analysis
- Instrumenting Code to Solve Specific Issues
- Bus Signal Timing Analysis
- Signal Integrity Analysis
- Agilent 16700 Networking

Related Agilent Literature

Pub. Number

*Agilent Technologies 16700 Series
Logic Analysis System, Product Overview*

5968-9661E

*Passively Probing a Motorola M-CORE
Target System with E5346A High-Density
Termination Adapters, Product Note*

5968-2503E

Agilent Technologies' Test and Measurement Support, Services, and Assistance

Agilent Technologies aims to maximize the value you receive, while minimizing your risk and problems. We strive to ensure that you get the test and measurement capabilities you paid for and obtain the support you need. Our extensive support resources and services can help you choose the right Agilent products for your applications and apply them successfully. Every instrument and system we sell has a global warranty. Support is available for at least five years beyond the production life of the product. Two concepts underlie Agilent's overall support policy: "Our Promise" and "Your Advantage."

Our Promise

Our Promise means your Agilent test and measurement equipment will meet its advertised performance and functionality. When you are choosing new equipment, we will help you with product information, including realistic performance specifications and practical recommendations from experienced test engineers. When you use Agilent equipment, we can verify that it works properly, help with product operation, and provide basic measurement assistance for the use of specified capabilities, at no extra cost upon request. Many self-help tools are available.

Your Advantage

Your Advantage means that Agilent offers a wide range of additional expert test and measurement services, which you can purchase according to your unique technical and business needs. Solve problems efficiently and gain a competitive edge by contracting with us for calibration, extra-cost upgrades, out-of-warranty repairs, and on-site education and training, as well as design, system integration, project management, and other professional engineering services. Experienced Agilent engineers and technicians worldwide can help you maximize your productivity, optimize the return on investment of your Agilent instruments and systems, and obtain dependable measurement accuracy for the life of those products.

For more assistance with your test & measurement needs go to:

www.agilent.com/find/assist

Or contact the test and measurement experts at Agilent Technologies (During normal business hours)

United States:

(tel) 1 800 452 4844

Canada:

(tel) 1 877 894 4414

(fax) (905) 282 6495

Europe:

(tel) (31 20) 547 2323

(fax) (31 20) 547 2390

Japan:

(tel) (81) 426 56 7832

(fax) (81) 426 56 7840

Latin America:

(tel) (305) 269 7500

(fax) (305) 269 7599

Australia:

(tel) 1 800 629 485

(fax) (61 3) 9210 5947

New Zealand:

(tel) 0 800 738 378

(fax) 64 4 495 8950

Asia Pacific:

(tel) (852) 3197 7777

(fax) (852) 2506 9284

Product specifications and descriptions in this document subject to change without notice.

Copyright© 1999, 2000
Agilent Technologies
Printed in USA 11-00
5968-1982E



Agilent Technologies
Innovating the HP Way