

# Agilent 1180C

## Testmobile Scope Cart

### Data Sheet

#### Add mobility to your instruments

The Agilent 1180C testmobile scope cart provides convenient mobility of test equipment to make it readily available when needed and effectively extend the amount of lab bench space. Allows several operators to cost effectively share expensive equipment.

#### Features

- Ergonomic design, test equipment is operator-accessible whether seated or standing
- Heavy-duty casters make moving instruments easy
- Includes a steel buckle and nylon strap to secure instruments to the cart
- Attractive quartz gray color
- Tilt tray adjusts 30-plus degrees for viewing comfort

#### Specifications

- Material: Cold-rolled steel
- Weight: 25.9 kg (57 lbs)
- Color: Quartz gray
- Casters: 101 mm (4 in) diameter
- Tilt Tray Load Capacity: 29.5 kg (65 lbs)
- Total Load Capacity: 59 kg (130 lbs)
- Tilt Tray Width: 457 mm (18 in)
- Tilt Tray Depth: 457 mm (18 in)

#### Installation

The 1180C is shipped virtually assembled except for its handle and casters. Place the handle in the rear top of the cart and secure with screws provided. Insert the casters in the corner holes on the underside of the cart. Attach the nylon strap on the slots of the instrument tray and thread through buckle.

Tools required for installation:

- Torx T25 screwdriver



#### What you get in the box

- Scope cart assembly with tray
- Torx T25 screwdriver
- Tubular handle
- 4 casters
- All mounting hardware
- Nylon strap with steel buckle
- Installation instructions

#### What changed

- Color changed from parchment white to quartz gray



## Related Products

Other testmobiles available are:

- 1181B – Agilent testmobile system cart
- 1182B – Agilent testmobile instrument cart

## Optional Accessory

**35183B** Work surface

## Replacement Parts

**1530-2054** Tie-down assembly strap

**1492-0134** Caster, swivel with brake

## Warranty

Three-year replacement

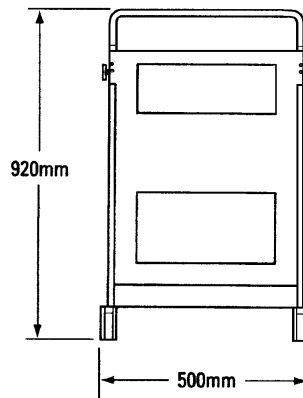
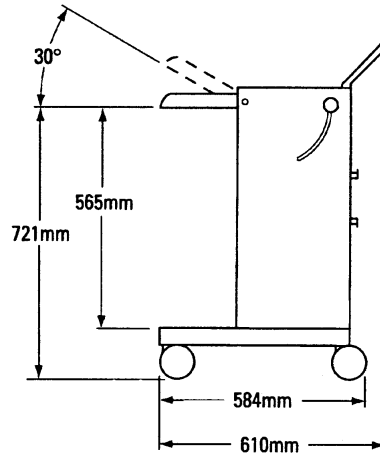

## Agilent Technologies' Test and Measurement Support, Services, and Assistance

Agilent Technologies aims to maximize the value you receive, while minimizing your risk and problems. We strive to ensure that you get the test and measurement capabilities you paid for and obtain the support you need. Our extensive support resources and services can help you choose the right Agilent products for your applications and apply them successfully. Every instrument and system we sell has a global warranty. Support is available for at least five years beyond the production life of the product. Two concepts underlie Agilent's overall support policy: "Our Promise" and "Your Advantage."

### Our Promise

"Our Promise" means your Agilent test and measurement equipment will meet its advertised performance and functionality. When you are choosing new equipment, we will help you with product information, including realistic performance specifications and practical recommendations from experienced test engineers. When you use Agilent equipment, we can verify that it works properly, help with product operation, and provide basic measurement assistance for the use of specified capabilities, at no extra cost upon request. Many self-help tools are available.

### Your Advantage

"Your Advantage" means that Agilent offers a wide range of additional expert test and measurement services, which you can purchase according to your unique technical and business needs. Solve problems efficiently and gain a competitive edge by contracting with us for calibration, extra-cost upgrades, out-of-warranty repairs, and on-site education and training, as well as design, system integration, project management, and other professional services. Experienced Agilent engineers and technicians worldwide can help you maximize your productivity, optimize the return on investment of your Agilent instruments and systems, and obtain dependable measurement accuracy for the life of those products.

**Get assistance with all your test and measurement needs at:**  
[www.agilent.com/find/assist](http://www.agilent.com/find/assist)

Product specifications and descriptions in this document subject to change without notice.

Copyright © 2001 Agilent Technologies  
Printed in U.S.A. May 1, 2001  
5988-2771EN



**Agilent Technologies**