



# Agilent 35181N

## Testmobile Keyboard Shelf

Data Sheet

### Mount a keyboard to a testmobile

The Agilent 35181N testmobile keyboard shelf allows for a keyboard to be mounted onto the top of a system or instrument cart.

### Features

- Holds all standard keyboards up to 2.27 kg (5 lbs)
- Attractive quartz gray color
- All mounting hardware included

### Specifications

- Material: Cold-rolled steel
- Weight: 3.63 kg (8 lbs)
- Color: Quartz gray
- Length: 521 mm (20.5 in)
- Depth: 220 mm (8.66 in)
- Supported Weight: 2.27 kg (5 lbs)

### Installation

Attach the brackets to the tilting tray. Install the keyboard holder and secure with provided hardware.

Tools required for installation:

- Torx T15 Screwdriver

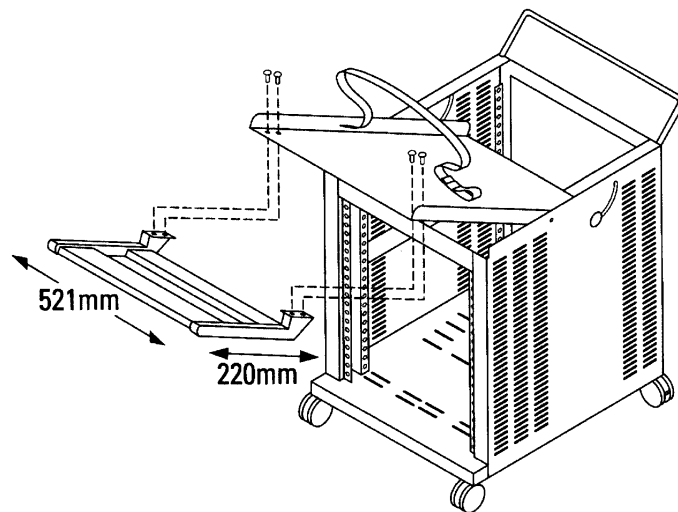

### What you get in the box

- Keyboard tray
- Left and right end brackets
- Dual lock adhesive pads
- Torx T15 screwdriver
- All mounting hardware
- Installation instructions

### What changed

Replaces: 35181B

- Color changed from parchment white to quartz gray

### Compatibility

The 35181N can be used with either:

- 1181B – Agilent testmobile system cart
- 1182B – Agilent testmobile instrument cart

### Warranty

Three-year replacement



Agilent Technologies

**Agilent Technologies' Test and Measurement Support, Services, and Assistance**

Agilent Technologies aims to maximize the value you receive, while minimizing your risk and problems. We strive to ensure that you get the test and measurement capabilities you paid for and obtain the support you need. Our extensive support resources and services can help you choose the right Agilent products for your applications and apply them successfully. Every instrument and system we sell has a global warranty. Support is available for at least five years beyond the production life of the product. Two concepts underlie Agilent's overall support policy: "Our Promise" and "Your Advantage."

**Our Promise**

"Our Promise" means your Agilent test and measurement equipment will meet its advertised performance and functionality. When you are choosing new equipment, we will help you with product information, including realistic performance specifications and practical recommendations from experienced test engineers. When

you use Agilent equipment, we can verify that it works properly, help with product operation, and provide basic measurement assistance for the use of specified capabilities, at no extra cost upon request. Many self-help tools are available.

**Your Advantage**

"Your Advantage" means that Agilent offers a wide range of additional expert test and measurement services, which you can purchase according to your unique technical and business needs. Solve problems efficiently and gain a competitive edge by contracting with us for calibration, extra-cost upgrades, out-of-warranty repairs, and on-site education and training, as well as design, system integration, project management, and other professional services. Experienced Agilent engineers and technicians worldwide can help you maximize your productivity, optimize the return on investment of your Agilent instruments and systems, and obtain dependable measurement accuracy for the life of those products.

By internet, phone, or fax, get assistance with all your test and measurement needs.

**Online Assistance**

[www.agilent.com/find/assist](http://www.agilent.com/find/assist)

**Phone or Fax**

United States:

(tel) 1 800 452 4844

Canada:

(tel) 1 877 894 4414

(fax) (905) 282 6495

Europe:

(tel) (31 20) 547 2323

(fax) (31 20) 547 2390

Japan:

(tel) (81) 426 56 7832

(fax) (81) 426 56 7840

Latin America:

(tel) (305) 269 7500

(fax) (305) 269 7599

Australia:

(tel) 1 800 629 485

(fax) (61 3) 9210 5947

New Zealand:

(tel) 0 800 738 378

(fax) (64 4) 495 8950

Asia Pacific:

(tel) (852) 3197 7777

(fax) (852) 2506 9284

Product specifications and descriptions in this document subject to change without notice.

Copyright © 2001 Agilent Technologies

Printed in U.S.A. May 1, 2001

5988-2773EN



**Agilent Technologies**