



N4865A GPIB-to-LAN Adapter

Data Sheet

Key Features

- GPIB to LAN interface module for use with Agilent's 7000 and 9000 Series oscilloscopes
- Custom software or driver not required on either the controller or instrument
- Fast data transfer rates
- Power from USB host port of scope or PC
- Comes with a USB power cable, user's guide in electronic form, declaration of conformity in electronic form and crossover Ethernet cable

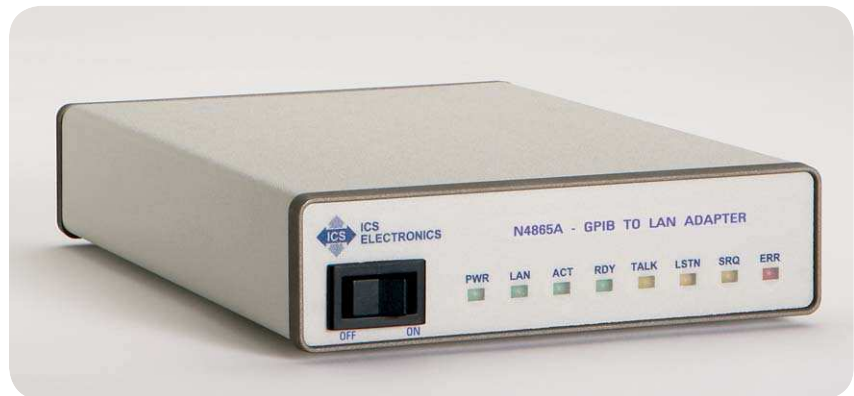

Agilent's N4865A is a GPIB to LAN adapter that provides a GPIB interface for VXI-11.3 compatible LAN based oscilloscopes such as Agilent's 7000 and 9000 Series. Using the N4865A, GPIB applications running on a computer can transparently interface to a LAN based instrument as if it were a GPIB instrument.

The N4865A will not require any custom software or driver on either the controller or the instrument beyond whatever GPIB software is already in use. The product is compatible with the LXI AutoIP standard or can use a static IP address. When shipped, the product is configured to operate with a static IP address (169.254.48.65) and to work with a VXI 11.3 compatible LAN instrument with a single IP address. The product includes a HTML based interface which can be accessed

via a standard (PC based) TCP/IP connection. This interface allows access to all relevant configuration settings within the product, specifically including the GPIB address, static IP address, and other communication settings.

The N4865A has two ways to connect to an instrument after the power-on self test.

- 1) The user can specify an IP address for the instrument and the N4865A will attempt to connect to it.
- 2) If the N4865A's AutoFind function is enabled, the N4865A will do an UDF broadcast and attempt to connect it to the first VXI-11.3 compatible instrument that replies to the broadcast.



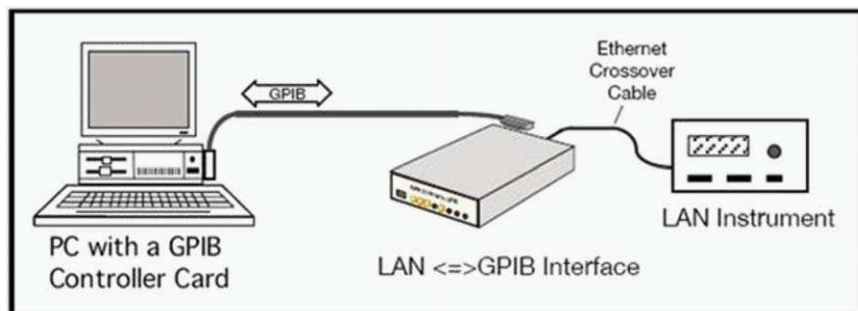

Figure 1. N4865A direct instrument connection

Characteristics

- System requirements and compatibility
 - Compatible with Agilent oscilloscopes and other Agilent LXI instruments with an Ethernet
 - Any computer with a GPIB card and the Agilent I/O library or NI GPIB library
 - IEEE488 GPIB interface meets the IEEE standard 488.1-1987 standard and has the following capabilities
SH1, AH1, T6, L4, SR1, PP0, DC0, RL0, DT0, C1-C4 and C9
- Construction: All metal case (providing proper EMI/RFI protection and rack mounting capability) – Rack mount kit available from ICS.
- Configuration: direct instrument connection – See figure 1
- Power: via instrument’s host USB port
- Connectors: IEEE488 GPIB connector with metal studs, Ethernet interface RJ-45 connector
- Controls: Power switch on front panel, LAN reset switch on rear panel
- Included accessories:
 - X1 GPIB to LAN interface module
 - X1 USB power cable
 - X1 Ethernet crossover cable
 - X1 Agilent user’s manual
 - X1 Declaration of Conformity in electronic or paper form
- Size: 7.65” L x 5.57” W x 1.52” H (18.92 cm L x 14.15 cm W x 3.86 cm W)
- Weight: 3 lbs (1.4 kg) including adapter
- Temperature: operating - -10 °C to +55 °C, Storage - -40 °C to +70 °C
- Humidity: 0-90% RH without condensation
- Shock/Vibration: Tested to Agilent’s normal GP instrument standard

For more information on Agilent Technologies’ products, applications or services, please contact your local Agilent office. The complete list is available at:

www.agilent.com/find/contactus

Americas

Canada	(877) 894-4414
Latin America	305 269 7500
United States	(800) 829-4444

Asia Pacific

Australia	1 800 629 485
China	800 810 0189
Hong Kong	800 938 693
India	1 800 112 929
Japan	0120 (421) 345
Korea	080 769 0800
Malaysia	1 800 888 848
Singapore	1 800 375 8100
Taiwan	0800 047 866
Thailand	1 800 226 008

Europe & Middle East

Austria	01 36027 71571
Belgium	32 (0) 2 404 93 40
Denmark	45 70 13 15 15
Finland	358 (0) 10 855 2100
France	0825 010 700
Germany	07031 464 6333
Ireland	1890 924 204
Israel	972-3-9288-504/544
Italy	39 02 92 60 8484
Netherlands	31 (0) 20 547 2111
Spain	34 (91) 631 3300
Sweden	0200-88 22 55
Switzerland	0800 80 53 53
United Kingdom	44 (0) 118 9276201

Other European Countries:

www.agilent.com/find/contactus

Revised: October 1, 2008

Product specifications and descriptions in this document subject to change without notice.

© Agilent Technologies, Inc. 2009
Printed in USA, September 1, 2009
5990-4266EN

