

Agilent 1GG6-8054 DC–75 GHz SPDT GaAs MMIC Switch

TC950

Data Sheet

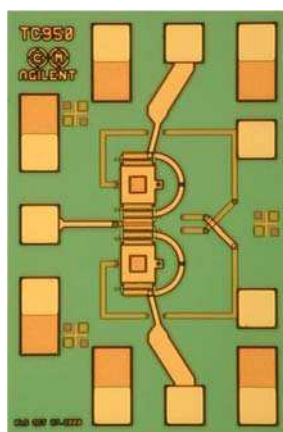

Chip Size: 630 x 930 μm (24.8 x 36.6 mils)
 Chip Size Tolerance: $\pm 10 \mu\text{m}$ (± 0.4 mils)
 Chip Thickness: 50 $\pm 15 \mu\text{m}$ (2.0 \pm 0.6 mils)
 Pad Dimensions: 80 x 80 μm (3.2 x 3.2 mils)

Features

- Frequency Range:
DC-75 GHz
- Insertion Loss:
2.6 dB typical @ 50 GHz
- Isolation:
29 dB typical @ 50 GHz
- Return Loss:
>10 dB (Both Input & Selected Output)
- $P_{-1\text{dB}}$:
+15 dBm
- Harmonics:
<-50 dBc
- Settling Time:
< ns (0.1 dB)

Description

The TC950 is a GaAs monolithic microwave integrated circuit (MMIC) switch designed for low insertion loss and high isolation from DC to 75 GHz. It is intended for use as a general-purpose, single-pole, double-throw (SP-DT) switch. One series and two shunt pHEMTs per throw typically provide 2.6 dB insertion loss and 29 dB isolation at 50 GHz. This IC is fabricated in MWTC's advanced 0.12- μm gate-length GaAs pHEMT process.

Absolute Maximum Ratings^[1]

Symbol	Parameters/Conditions	Min.	Max.	Units
V_{sel}	Select Voltages 1 & 2	-3.5	+3.5	volts
P_{in}	RF Input Power		+17	dBm
T_{ch}	Maximum Channel Temperature		150	$^{\circ}\text{C}$
$T_{\text{bs}}^{[2]}$	Die Backside Temperature	-55	+85	$^{\circ}\text{C}$
T_{stg}	Storage Temperature	-65	+165	$^{\circ}\text{C}$
T_{max}	Maximum Assembly Temperature (for 60 seconds maximum)		+300	$^{\circ}\text{C}$

Notes:

- 1.Operation in excess of any one of these conditions may result in permanent damage to this device.
- 2.MTTF > 1×10^6 hours @ $T_{\text{bs}} = 85^{\circ}\text{C}$. Operation in excess of maximum backside temperature (T_{bs}) will degrade MTTF.

DC Specifications/Physical Properties ^[1]

Symbol	Parameters/Conditions	Min.	Typ.	Max.	Units
I_{sel}	Leakage Current @ +3V		+1	+20	μ A
I_{sel}	Leakage Current @ -3V	-20	-4		μ A
Θ_{ch-s}	Thermal Resistance ($T_{substrate} = 25^{\circ}\text{C}$)				

1. $Z_0 = 50\Omega$, $T_A = 25^{\circ}\text{C}$

RF Specifications ^{[1], [2]}

Symbol	Parameters/Conditions	Freq.	Min.	Typ.	Max.	Units
BW	Operating Bandwidth		DC		75	GHz
		1 GHz		1.75		dB
IL	Insertion Loss, RF_{in} to RF_{out} (ON throw)	50 GHz		2.6	3.0	dB
		67 GHz		3.4		dB
		75 GHz		4.2		dB
ISO	Isolation, RF_{in} to RF_{out} (OFF throw)	1 GHz		65		dB
		50 GHz		29		dB
		67 GHz		27		dB
		75 GHz		26		dB
ISO	Isolation, RF_{out} to RF_{out} (OFF throw)	1 GHz		62		dB
		50 GHz		31		dB
		67 GHz		29		dB
		75 GHz		28		dB
RL_{in}	Input Return Loss, 50 GHz	50 GHz		16		dB
		75 GHz		10		dB
RL_{out-ON}	Output Return Loss (ON throw)	50 GHz		16		dB
		75 GHz		16		dB
$RL_{out-OFF}$	Output Return Loss (OFF throw)	1 GHz		3.5		dB
P_{-1dB}	Output Power at 1 dB Gain Compression	18 GHz		+15		dBm
H_2	2 nd Harmonic, $P_{out} \leq +10$ dBm (Fund = 100 MHz, 2 GHz, and 12 GHz)	50 GHz		-50		dBc
H_3	3 rd Harmonic $P_{out} \leq +10$ dBm (Fund = 100 MHz, 2 GHz, and 12 GHz)	50 GHz		-50		dBc
TOI	3 rd Order Intermodulation Intercept, $RF_{in1} = RF_{in2} \leq +10$ dBm, 100 MHz ($\Delta f = 1$ MHz), 2 GHz ($\Delta f = 100$ MHz), 12 GHz ($\Delta f = 100$ MHz)	50 GHz		+31		dBm

Notes:

1. $Z_0 = 50\Omega$, ac coupled, $T_A = 25^{\circ}\text{C}$.

2. These RF specifications can be achieved when the device is properly biased and heat sunk. Specifications are based on performance attained on-chip with a wafer probe system.

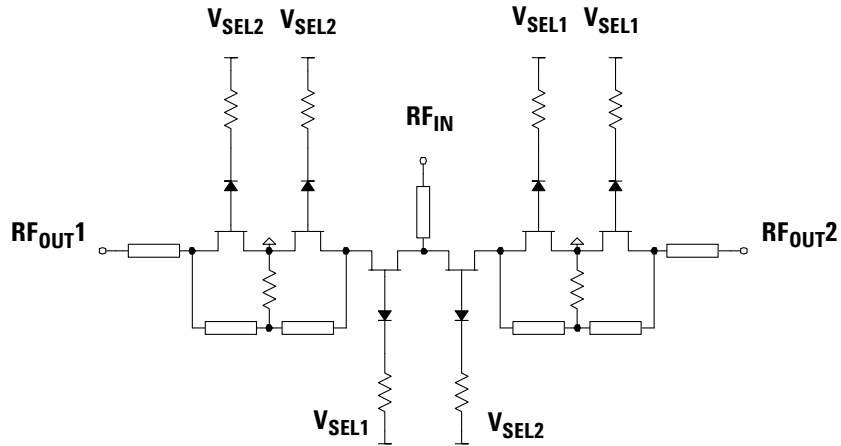

Figure 1.
1GG6-8054 Schematic

Applications

The TC950 is a general-purpose SPDT switch IC suitable for microwave and millimeter-wave switching applications. The TC950 can be used in instrumentation, communications, radar, ECM, EW, fiber optic, and many other systems requiring SPDT switching. It can be used for pulse modulation, port isola-

tion, transfer switching, high-speed switching, replacement of mechanical switches, and many other applications.

Operation

The RF input and output ports may be DC or AC-coupled. If DC-coupled, the voltages of the input and output ports must be within ± 0.25 Volts of ground for guaranteed switch performance.

Maximum OFF-state isolation is obtained with unequal select voltages. The Short and Open states both provide some degree of isolation, but not over the entire bandwidth of the device. In addition, the Open state is not recommended because of potentially destructive overvoltage stress caused by high impedance values at the input and output ports.

Recommended Operating Conditions

State	V_{SEL1}	V_{SEL2}	RF_{OUT1}	RF_{OUT2}
RF_{OUT1} ON	+3V	-3V	ON	OFF
RF_{OUT2} ON	-3V	+3V	OFF	ON
Short	+3V	+3V	ON	ON
Open	-3V	-3V	OFF	OFF

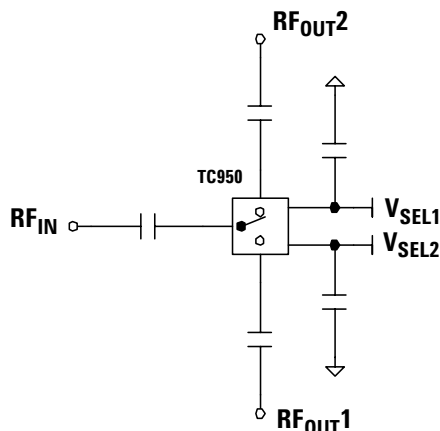

Figure 2.
1GG6-8054 Biasing Diagram

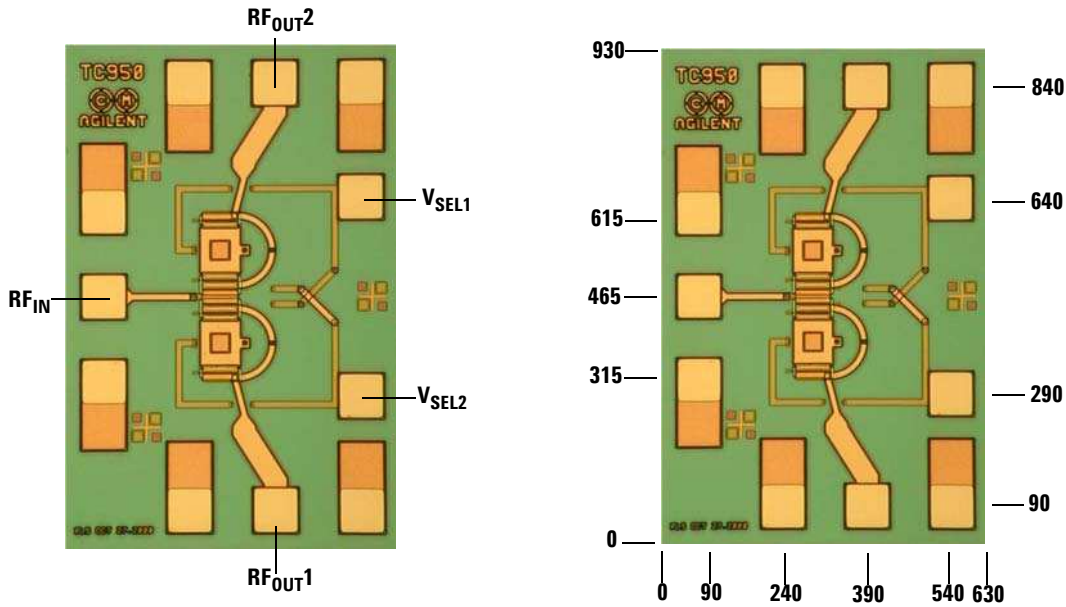

Figure 3.
1GG6-8054 Chip Bias/RF Bond Pad Locations

Assembly Techniques

Epoxy die-attach using a conductive epoxy or solder die-attach using a fluxless gold-tin solder preform are both suitable assembly methods. The IC must be attached to an electrically conductive surface that forms DC and RF ground for the circuit.

To maintain adequate impedance matching properties at the RF input and output ports, 500-

line/inch gold wire mesh bonds (or equivalent) should be used. These bonds should be kept as short as possible to minimize parasitic inductance. DC bias may be supplied through conventional 0.7-mil gold wire bonds. In both cases, thermosonic wedge bonding is recommended. The top and bottom metallization is gold.

GaAs MMICs are ESD sensitive. ESD preventive measures must

be employed in all aspects of storage, handling and assembly. MMIC ESD precautions, handling considerations, and die attach and bonding methods are critical factors in successful GaAs MMIC performance and reliability

For more detailed information see Agilent Technologies' application note #54, "GaAs MMIC ESD, Die Attach and Bonding Guidelines."

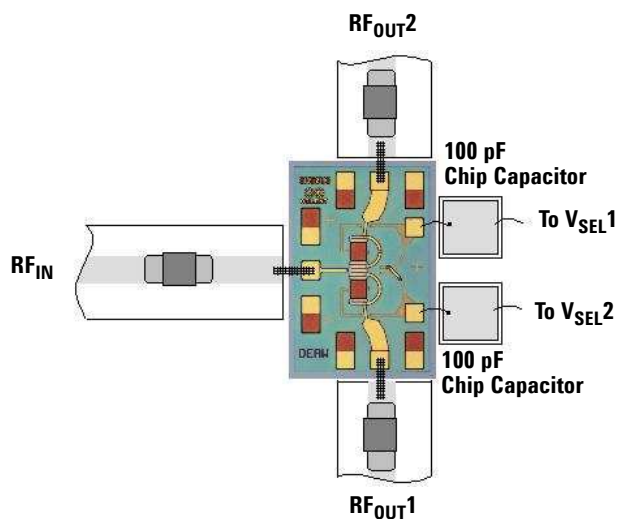

Figure 4.
1GG6-8054 Chip Assembly diagram

S-Parameters^[1], RF_{IN} to RF_{OUT1}

(T_A=25°C, V_{SEL1}=+3V, V_{SEL2}=-3V, Z₀=50 ohms) RF_{OUT1}: ON RF_{OUT2}: OFF

Freq GHz	S ₁₁			S ₁₂			S ₂₁			S ₂₂		
	dB	Mag	Ang	dB	Mag	Ang	dB	Mag	Ang	dB	Mag	Ang
1	-15.7	0.165	-3.1	-1.8	0.809	-3.5	-1.9	0.808	-3.3	-16.1	0.156	-5.2
2	-15.7	0.164	-5.4	-1.9	0.807	-6.4	-1.9	0.807	-6.5	-16.2	0.154	-9.2
4	-15.9	0.161	-10.4	-1.9	0.805	-12.7	-1.9	0.805	-12.7	-16.2	0.154	-18.8
6	-16.0	0.158	-15.7	-1.9	0.802	-18.8	-1.9	0.802	-19.0	-16.4	0.152	-27.6
8	-16.2	0.154	-20.7	-1.9	0.799	-25.1	-2.0	0.798	-25.1	-16.6	0.148	-36.3
10	-16.5	0.15	-24.6	-2.0	0.796	-31.0	-2.0	0.796	-31.2	-16.8	0.144	-45.0
12	-16.7	0.147	-28.2	-2.0	0.796	-36.8	-2.0	0.796	-37.2	-16.8	0.144	-53.1
14	-16.8	0.144	-34.7	-2.0	0.796	-43.3	-2.0	0.795	-43.4	-16.8	0.145	-63.0
16	-17.4	0.135	-39.8	-2.0	0.792	-49.5	-2.0	0.791	-49.6	-17.0	0.141	-72.3
18	-17.7	0.131	-44.9	-2.0	0.79	-55.5	-2.1	0.789	-56.0	-17.3	0.136	-83.6
20	-18.3	0.122	-51.1	-2.1	0.787	-61.5	-2.1	0.787	-62.4	-17.1	0.139	-95.0
22	-19.0	0.112	-56.5	-2.1	0.784	-68.1	-2.1	0.783	-68.2	-17.2	0.138	-103.1
24	-19.6	0.105	-60.3	-2.1	0.783	-74.4	-2.1	0.782	-74.3	-17.5	0.134	-112.0
26	-20.0	0.1	-68.0	-2.2	0.78	-80.5	-2.2	0.779	-80.7	-17.6	0.132	-125.6
28	-21.1	0.088	-76.1	-2.2	0.778	-86.6	-2.2	0.776	-87.2	-17.5	0.134	-136.3
30	-22.5	0.075	-81.0	-2.2	0.774	-92.8	-2.2	0.772	-93.4	-17.3	0.137	-148.5
32	-23.7	0.065	-83.2	-2.3	0.77	-99.0	-2.3	0.77	-99.9	-17.5	0.134	-157.3
34	-24.3	0.061	-89.8	-2.3	0.769	-105.1	-2.3	0.768	-106.3	-17.8	0.129	-169.8
36	-25.2	0.055	-96.1	-2.3	0.768	-111.5	-2.3	0.766	-112.8	-17.7	0.131	176.5
38	-27.5	0.042	-105.3	-2.3	0.764	-118.0	-2.3	0.764	-119.0	-16.8	0.144	169.0
40	-27.3	0.043	-102.6	-2.3	0.764	-124.8	-2.3	0.764	-125.6	-17.8	0.129	156.6
42	-27.5	0.042	-123.5	-2.4	0.758	-131.5	-2.4	0.758	-131.8	-16.7	0.146	143.8
44	-28.4	0.038	-131.3	-2.4	0.756	-138.2	-2.4	0.757	-138.8	-16.6	0.148	132.8
46	-28.9	0.036	-137.9	-2.5	0.752	-144.8	-2.5	0.751	-145.1	-16.4	0.152	126.2
48	-27.3	0.043	-150.2	-2.5	0.751	-151.5	-2.5	0.749	-151.9	-16.5	0.149	113.6
50	-25.8	0.051	-158.9	-2.5	0.747	-157.6	-2.5	0.746	-159.4	-16.7	0.147	106.2
52	-23.9	0.064	-175.9	-2.6	0.741	-164.7	-2.6	0.74	-166.4	-15.4	0.17	89.0
54	-24.0	0.063	170.4	-2.7	0.732	-171.5	-2.7	0.732	-173.3	-15.0	0.178	89.3
56	-22.9	0.072	168.4	-2.8	0.727	-178.3	-2.8	0.727	179.6	-15.9	0.161	77.7
58	-20.7	0.092	170.6	-2.8	0.724	174.4	-2.8	0.722	172.6	-16.2	0.154	66.4
60	-18.5	0.119	159.0	-2.9	0.713	167.2	-3.0	0.711	165.3	-15.0	0.178	57.9
62	-17.2	0.138	151.3	-3.0	0.704	160.4	-3.0	0.704	158.2	-15.5	0.168	49.1
64	-15.8	0.162	140.3	-3.2	0.69	153.1	-3.2	0.688	151.0	-14.3	0.192	44.9
66	-14.7	0.185	135.9	-3.4	0.677	145.9	-3.4	0.674	143.7	-16.6	0.148	35.3
68	-13.4	0.214	126.8	-3.6	0.66	139.5	-3.6	0.658	137.1	-14.8	0.183	23.1
70	-12.4	0.239	120.6	-3.8	0.646	132.7	-3.8	0.644	130.1	-15.2	0.174	21.1
72	-11.8	0.256	112.9	-4.0	0.629	126.1	-4.0	0.628	123.7	-16.5	0.149	25.2
74	-10.6	0.294	107.2	-4.1	0.621	119.7	-4.2	0.62	117.0	-16.2	0.155	-6.0
76	-9.9	0.319	97.2	-4.3	0.609	113.5	-4.3	0.61	111.1	-15.3	0.171	8.2
78	-9.5	0.334	91.6	-4.4	0.601	105.9	-4.4	0.601	103.3	-18.2	0.123	-2.9
80	-9.0	0.353	85.2	-4.7	0.583	99.2	-4.7	0.581	96.2	-19.6	0.105	2.0

1. S-parameters measured on-wafer with a wafer probe system at T_A=25°C

S-Parameters^[1], RF_{IN} to RF_{OUT1}

(T_A=25°C, V_{SEL1}=-3V, V_{SEL2}=+3V, Z₀=50 ohms) RF_{OUT1}: OFF RF_{OUT2}: ON

Freq GHz	S ₁₁			S ₁₂			S ₂₁			S ₂₂		
	dB	Mag	Ang	dB	Mag	Ang	dB	Mag	Ang	dB	Mag	Ang
1	-15.5	0.167	-3.0	-64.1	0.001	93.0	-63.4	0.001	92.3	-3.7	0.653	177.0
2	-15.7	0.164	-15.8	-56.7	0.001	96.5	-56.5	0.001	95.9	-3.7	0.652	174.4
4	-18.1	0.124	-13.3	-50.6	0.003	91.9	-50.6	0.003	91.9	-3.8	0.649	168.8
6	-17.9	0.127	-18.7	-46.7	0.005	84.5	-46.7	0.005	84.6	-3.8	0.649	163.2
8	-15.8	0.162	-9.6	-43.6	0.007	80.6	-43.6	0.007	80.5	-3.8	0.649	157.8
10	-16.8	0.144	-36.3	-41.8	0.008	72.6	-41.9	0.008	72.3	-3.8	0.649	152.3
12	-18.1	0.125	-16.7	-40.2	0.010	73.6	-40.2	0.010	73.3	-3.8	0.648	147.0
14	-17.7	0.130	-26.6	-39.2	0.011	65.0	-39.2	0.011	64.9	-3.8	0.646	141.6
16	-21.8	0.081	-20.5	-39.2	0.011	63.3	-39.2	0.011	63.3	-3.8	0.646	136.0
18	-25.2	0.055	-29.9	-38.4	0.012	60.2	-38.4	0.012	58.3	-3.8	0.647	130.8
20	-19.3	0.109	-34.5	-37.1	0.014	56.6	-37.1	0.014	55.7	-3.8	0.647	125.9
22	-17.5	0.134	-62.9	-36.5	0.015	49.7	-36.5	0.015	51.3	-3.8	0.642	120.5
24	-17.3	0.136	-67.9	-35.4	0.017	46.5	-35.4	0.017	46.5	-3.8	0.645	114.7
26	-23.1	0.070	-85.5	-35.9	0.016	47.8	-35.9	0.016	49.0	-3.8	0.644	109.7
28	-21.2	0.087	-37.9	-34.4	0.019	50.1	-34.4	0.019	49.6	-3.8	0.644	104.6
30	-24.0	0.063	-33.7	-33.6	0.021	47.0	-34.0	0.020	46.6	-3.8	0.649	99.6
32	-26.0	0.050	-94.3	-33.6	0.021	39.4	-33.6	0.021	38.2	-3.9	0.641	93.9
34	-25.5	0.053	-124.4	-33.6	0.021	36.3	-33.6	0.021	35.0	-3.8	0.647	88.1
36	-20.0	0.100	-85.9	-31.7	0.026	32.5	-32.0	0.025	30.7	-3.7	0.650	83.1
38	-24.0	0.063	-120.9	-32.4	0.024	27.8	-32.4	0.024	27.5	-3.8	0.647	78.5
40	-25.7	0.052	-24.8	-31.7	0.026	32.4	-31.7	0.026	31.5	-3.8	0.648	71.1
42	-23.9	0.064	-52.2	-31.1	0.028	28.8	-30.8	0.029	27.7	-3.7	0.650	67.4
44	-25.4	0.054	-92.0	-30.5	0.030	23.0	-30.5	0.030	22.6	-3.8	0.648	61.6
46	-23.3	0.068	-175.5	-30.8	0.029	17.1	-30.8	0.029	16.7	-3.9	0.640	56.3
48	-28.0	0.040	172.6	-30.2	0.031	16.2	-30.2	0.031	16.0	-3.9	0.637	50.0
50	-23.0	0.071	-124.2	-29.1	0.035	10.9	-29.4	0.034	10.1	-4.0	0.628	44.6
52	-21.9	0.080	-140.9	-28.9	0.036	6.3	-28.6	0.037	5.1	-3.8	0.647	39.8
54	-18.4	0.120	168.5	-29.1	0.035	0.3	-29.1	0.035	-1.3	-4.1	0.625	36.8
56	-16.1	0.156	165.0	-28.6	0.037	-7.0	-28.6	0.037	-8.0	-4.3	0.613	29.3
58	-17.1	0.140	-174.6	-28.0	0.040	-8.2	-27.7	0.041	-10.6	-4.3	0.608	22.8
60	-17.1	0.139	177.6	-27.1	0.044	-13.6	-27.3	0.043	-15.2	-4.3	0.611	19.2
62	-17.7	0.130	120.3	-28.0	0.040	-16.7	-28.0	0.040	-18.0	-4.5	0.597	13.4
64	-14.2	0.196	108.0	-28.6	0.037	-23.1	-28.9	0.036	-23.8	-4.4	0.600	10.8
66	-12.9	0.227	136.0	-27.5	0.042	-35.4	-27.7	0.041	-34.3	-5.1	0.557	2.5
68	-12.1	0.247	144.5	-26.9	0.045	-37.6	-26.6	0.047	-41.2	-4.7	0.584	-1.1
70	-13.0	0.223	142.6	-26.2	0.049	-41.6	-26.4	0.048	-42.4	-4.9	0.566	-4.1
72	-13.2	0.218	105.1	-27.1	0.044	-44.9	-26.7	0.046	-47.0	-5.6	0.527	-7.6
74	-11.1	0.278	110.5	-26.9	0.045	-57.5	-27.1	0.044	-61.7	-5.1	0.553	-18.9
76	-8.0	0.396	100.4	-28.0	0.040	-69.3	-27.7	0.041	-71.6	-5.2	0.548	-15.6
78	-8.5	0.375	96.0	-27.5	0.042	-70.8	-27.3	0.043	-73.6	-5.8	0.513	-25.1
80	-8.6	0.370	78.3	-28.2	0.039	-71.6	-28.4	0.038	-74.4	-6.4	0.479	-29.7

1. S-parameters measured on-wafer with a wafer probe system at T_A=25°C

S-Parameters^[1], RF_{IN} to RF_{OUT1}

(T_A=25°C, V_{SEL1}= +3V, V_{SEL2}= +3V, Z₀= 50 ohms) RF_{OUT1}: ON RF_{OUT2}: ON

Freq GHz	S ₁₁			S ₁₂			S ₂₁			S ₂₂		
	dB	Mag	Ang	dB	Mag	Ang	dB	Mag	Ang	dB	Mag	Ang
1	-5.2	0.547	177.2	-17.9	0.128	-3.4	-17.9	0.128	-3.2	-2.9	0.713	176.8
2	-5.2	0.547	174.8	-17.9	0.128	-6.2	-17.9	0.128	-6.2	-3.0	0.712	174.1
4	-5.2	0.547	169.5	-17.9	0.127	-12.3	-18.0	0.126	-12.5	-3.0	0.709	168.2
6	-5.3	0.546	164.4	-18.1	0.125	-18.4	-18.1	0.125	-18.6	-3.0	0.706	162.3
8	-5.3	0.546	159.3	-18.2	0.123	-24.2	-18.2	0.123	-24.2	-3.0	0.704	156.6
10	-5.3	0.546	154.3	-18.3	0.121	-30.2	-18.3	0.121	-30.4	-3.1	0.702	151.0
12	-5.2	0.547	149.1	-18.6	0.118	-35.7	-18.6	0.118	-36.1	-3.1	0.698	145.4
14	-5.3	0.546	144.2	-18.8	0.115	-41.4	-18.8	0.115	-41.6	-3.2	0.694	139.8
16	-5.2	0.549	139.3	-19.1	0.111	-47.1	-19.1	0.111	-47.2	-3.2	0.692	134.1
18	-5.2	0.549	134.6	-19.3	0.108	-52.3	-19.3	0.108	-52.9	-3.2	0.689	128.8
20	-5.2	0.549	129.9	-19.6	0.105	-57.5	-19.7	0.104	-58.4	-3.3	0.686	123.8
22	-5.2	0.551	125.2	-19.9	0.101	-63.3	-19.9	0.101	-63.5	-3.4	0.679	118.3
24	-5.2	0.550	120.7	-20.3	0.097	-68.8	-20.3	0.097	-68.6	-3.4	0.679	112.5
26	-5.1	0.554	116.4	-20.7	0.092	-73.8	-20.7	0.092	-74.1	-3.4	0.675	107.5
28	-5.1	0.557	111.8	-21.0	0.089	-77.9	-21.1	0.088	-78.5	-3.4	0.673	102.4
30	-5.1	0.559	107.4	-21.4	0.085	-82.6	-21.4	0.085	-83.3	-3.4	0.676	97.5
32	-5.0	0.563	103.0	-21.7	0.082	-87.8	-21.7	0.082	-88.7	-3.5	0.667	91.8
34	-5.0	0.562	98.9	-22.2	0.078	-92.9	-22.2	0.078	-94.1	-3.5	0.670	86.1
36	-4.9	0.568	94.4	-22.6	0.074	-97.0	-22.6	0.074	-98.7	-3.5	0.671	81.2
38	-4.9	0.566	90.3	-23.0	0.071	-102.2	-23.0	0.071	-103.2	-3.5	0.667	76.6
40	-4.9	0.572	86.0	-23.5	0.067	-107.8	-23.5	0.067	-108.6	-3.5	0.667	69.4
42	-4.9	0.571	82.1	-24.0	0.063	-111.5	-24.0	0.063	-112.0	-3.5	0.667	65.7
44	-4.8	0.575	78.4	-24.6	0.059	-116.1	-24.4	0.060	-116.6	-3.5	0.665	60.0
46	-4.8	0.574	74.4	-25.0	0.056	-121.0	-24.9	0.057	-120.9	-3.7	0.655	54.8
48	-4.8	0.578	70.7	-25.4	0.054	-125.0	-25.5	0.053	-125.8	-3.7	0.652	48.6
50	-4.8	0.578	66.9	-26.2	0.049	-128.4	-26.0	0.050	-130.7	-3.8	0.642	43.3
52	-4.7	0.583	63.4	-26.6	0.047	-132.2	-26.6	0.047	-133.2	-3.6	0.660	38.6
54	-4.6	0.587	59.6	-27.1	0.044	-135.0	-27.1	0.044	-137.7	-3.9	0.635	35.6
56	-4.6	0.588	56.1	-27.7	0.041	-139.0	-27.7	0.041	-140.6	-4.1	0.625	28.3
58	-4.7	0.582	52.3	-28.2	0.039	-143.5	-28.2	0.039	-144.4	-4.2	0.618	21.7
60	-4.6	0.588	49.2	-28.9	0.036	-144.5	-28.9	0.036	-147.4	-4.2	0.620	18.1
62	-4.5	0.593	45.4	-29.1	0.035	-149.7	-29.4	0.034	-151.5	-4.3	0.608	12.4
64	-4.5	0.597	42.0	-29.9	0.032	-151.8	-29.6	0.033	-154.2	-4.3	0.610	9.9
66	-4.5	0.598	38.1	-30.5	0.030	-154.9	-30.2	0.031	-159.3	-4.9	0.566	1.6
68	-4.5	0.597	34.7	-31.1	0.028	-158.4	-31.4	0.027	-161.7	-4.6	0.592	-2.0
70	-4.5	0.595	30.5	-32.0	0.025	-159.3	-31.7	0.026	-160.0	-4.8	0.575	-4.8
72	-4.5	0.595	26.7	-32.4	0.024	-155.3	-32.0	0.025	-159.0	-5.4	0.536	-8.2
74	-4.7	0.582	23.2	-32.4	0.024	-160.7	-32.8	0.023	-164.5	-5.0	0.562	-19.6
76	-4.7	0.580	20.4	-33.2	0.022	-155.4	-32.8	0.023	-158.6	-5.1	0.557	-16.0
78	-4.8	0.574	17.0	-32.8	0.023	-158.2	-32.8	0.023	-162.0	-5.7	0.519	-25.7
80	-4.8	0.574	14.2	-32.8	0.023	-157.9	-32.8	0.023	-159.2	-6.3	0.486	-30.4

1. S-parameters measured on-wafer with a wafer probe system at T_A=25°C

S-Parameters^[1], RF_{IN} to RF_{OUT1}

(T_A=25°C, V_{SEL1}= -3V, V_{SEL2}= -3V, Z_o= 50 ohms) RF_{OUT1}: OFF RF_{OUT2}: OFF

Freq GHz	S ₁₁			S ₁₂			S ₂₁			S ₂₂		
	dB	Mag	Ang	dB	Mag	Ang	dB	Mag	Ang	dB	Mag	Ang
1	-0.1	0.994	-3.0	-42.5	0.008	95.2	-42.1	0.008	94.2	-0.5	0.942	-5.3
2	-0.1	0.993	-6.3	-34.9	0.018	91.9	-34.9	0.018	91.4	-0.6	0.937	-9.6
4	-0.1	0.992	-11.7	-28.2	0.039	83.4	-28.2	0.039	83.4	-0.6	0.929	-19.2
6	-0.2	0.976	-17.4	-24.4	0.060	74.4	-24.4	0.060	74.3	-0.7	0.926	-28.4
8	-0.3	0.967	-23.3	-21.8	0.081	65.4	-21.8	0.081	65.4	-0.7	0.918	-37.6
10	-0.3	0.964	-28.8	-19.7	0.104	56.5	-19.7	0.104	56.3	-0.9	0.906	-46.8
12	-0.4	0.956	-34.5	-17.9	0.127	47.2	-18.0	0.126	46.7	-0.9	0.900	-55.7
14	-0.5	0.947	-40.3	-16.9	0.143	38.5	-17.0	0.142	38.4	-1.0	0.893	-65.3
16	-0.6	0.934	-46.2	-15.9	0.160	30.8	-15.9	0.160	30.7	-1.1	0.879	-74.4
18	-0.7	0.925	-51.9	-14.9	0.179	23.1	-14.9	0.179	22.5	-1.2	0.867	-84.1
20	-0.9	0.906	-57.6	-14.2	0.196	15.4	-14.2	0.196	14.4	-1.4	0.855	-93.8
22	-1.0	0.891	-63.6	-13.5	0.212	7.1	-13.5	0.212	7.1	-1.5	0.839	-102.3
24	-1.2	0.873	-69.3	-12.9	0.227	-0.6	-12.9	0.227	-0.5	-1.6	0.828	-111.1
26	-1.3	0.864	-75.6	-12.3	0.242	-8.5	-12.4	0.241	-8.6	-1.8	0.815	-120.5
28	-1.5	0.843	-81.9	-11.9	0.253	-15.6	-12.0	0.252	-16.4	-1.9	0.804	-129.7
30	-1.7	0.826	-88.0	-11.5	0.266	-22.8	-11.5	0.265	-23.5	-2.0	0.795	-138.7
32	-1.9	0.804	-94.3	-11.1	0.278	-29.8	-11.1	0.278	-30.5	-2.1	0.786	-146.9
34	-2.0	0.794	-99.9	-10.6	0.294	-36.8	-10.6	0.294	-38.0	-2.2	0.776	-156.3
36	-2.3	0.763	-106.6	-10.4	0.303	-43.8	-10.4	0.302	-44.9	-2.3	0.770	-165.6
38	-2.5	0.749	-112.7	-10.0	0.316	-50.9	-10.0	0.316	-51.9	-2.2	0.775	-174.2
40	-2.8	0.726	-120.6	-9.7	0.329	-58.9	-9.7	0.329	-59.7	-2.3	0.770	176.9
42	-3.1	0.701	-127.2	-9.4	0.338	-66.5	-9.4	0.339	-66.8	-2.2	0.775	166.7
44	-3.3	0.680	-133.7	-9.1	0.349	-73.9	-9.1	0.349	-74.4	-2.2	0.773	157.4
46	-3.5	0.672	-139.0	-8.7	0.366	-80.4	-8.7	0.366	-80.7	-2.2	0.779	148.5
48	-3.7	0.651	-146.4	-8.4	0.381	-88.5	-8.4	0.380	-89.1	-2.2	0.779	138.8
50	-4.2	0.620	-153.6	-8.3	0.386	-95.3	-8.2	0.387	-97.0	-2.2	0.777	129.6
52	-4.5	0.597	-161.2	-8.0	0.396	-103.4	-8.0	0.397	-105.0	-2.1	0.788	117.7
54	-4.6	0.589	-166.8	-7.7	0.411	-110.1	-7.7	0.410	-111.9	-2.0	0.798	110.1
56	-4.9	0.566	-172.3	-7.4	0.426	-117.7	-7.4	0.426	-119.8	-2.1	0.786	99.9
58	-5.4	0.534	-179.9	-7.2	0.436	-126.1	-7.2	0.436	-127.9	-2.1	0.785	89.6
60	-5.7	0.518	171.3	-7.1	0.440	-135.4	-7.2	0.438	-137.2	-1.9	0.803	78.2
62	-5.3	0.541	163.8	-6.8	0.459	-144.9	-6.7	0.460	-146.9	-2.0	0.793	68.5
64	-5.3	0.543	157.5	-6.6	0.466	-153.7	-6.7	0.463	-156.1	-1.9	0.806	58.2
66	-6.4	0.479	153.8	-6.7	0.465	-161.0	-6.7	0.465	-163.2	-2.4	0.757	46.8
68	-7.2	0.438	149.3	-6.9	0.451	-168.2	-7.0	0.449	-170.4	-2.4	0.762	34.3
70	-7.6	0.417	140.4	-7.2	0.437	-176.6	-7.2	0.436	-179.0	-2.6	0.741	25.6
72	-6.6	0.470	132.6	-7.0	0.449	172.9	-7.0	0.447	170.8	-3.2	0.690	18.3
74	-6.9	0.452	131.2	-7.1	0.444	165.6	-7.1	0.442	163.1	-3.5	0.666	1.5
76	-6.1	0.497	128.5	-6.9	0.450	159.9	-6.9	0.451	157.8	-3.8	0.644	-1.2
78	-6.4	0.478	121.3	-7.1	0.443	152.0	-7.1	0.444	149.4	-4.7	0.582	-14.3
80	-6.1	0.496	111.7	-7.2	0.439	142.5	-7.2	0.438	139.5	-5.6	0.526	-23.0

1. S-parameters measured on-wafer with a wafer probe system at T_A=25°C

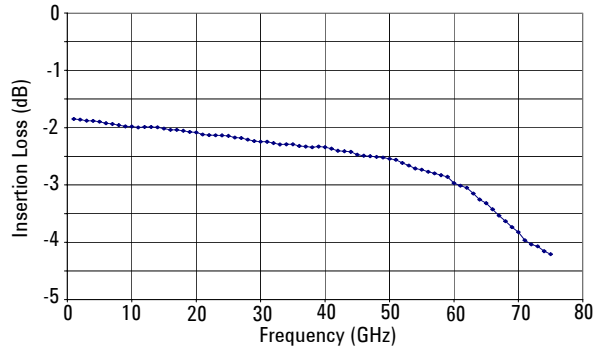

Figure 5.
Insertion Loss vs. Frequency[†]

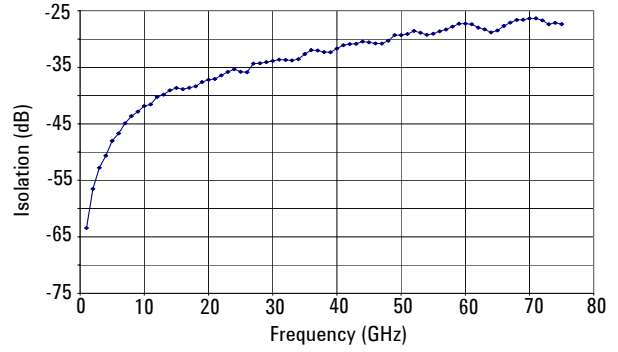

Figure 6.
Isolation vs. Frequency[†]

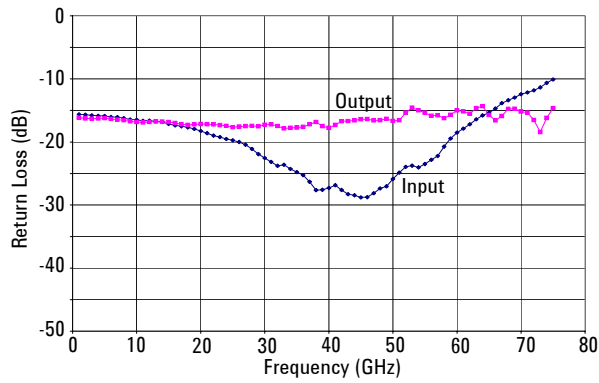

Figure 7.
Return Loss vs. Frequency[†]

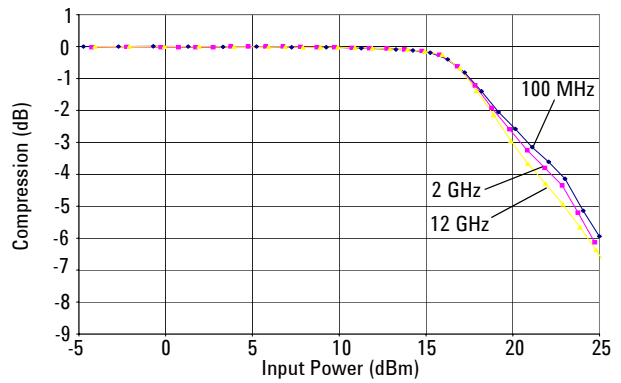

Figure 8.
Compression vs. Input Power[†]

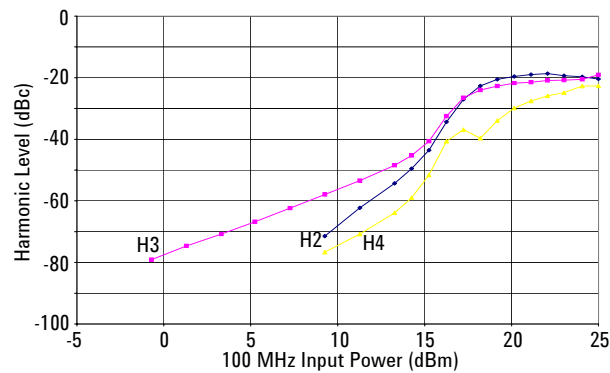

Figure 9.
**Harmonics vs. Input Power
@ 100 MHz Input[†]**

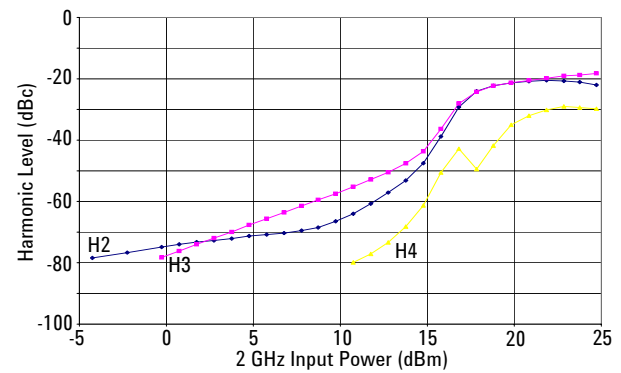

Figure 10.
**Harmonics vs. Input Power
@ 2 GHz Input[†]**

[†] All data was measured on-wafer with a wafer probe system at $T_A=25^\circ\text{C}$.

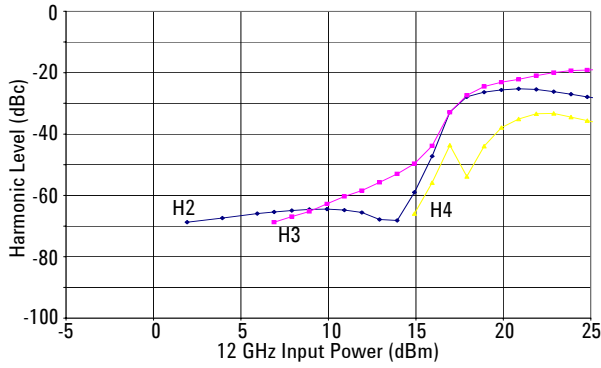

Figure 11.
Harmonics vs. Input Power
@ 12 GHz Input[†]

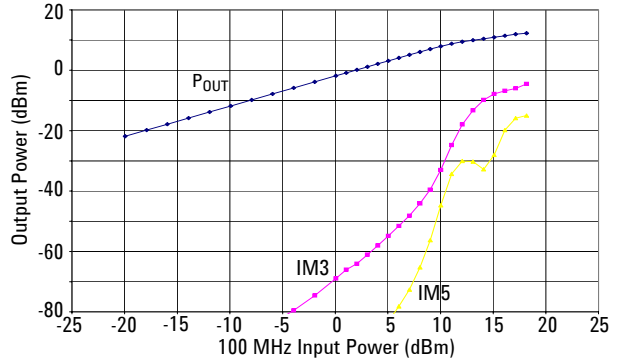

Figure 12.
Intermod Products vs. Input Power
@ 100 MHz Input[†]

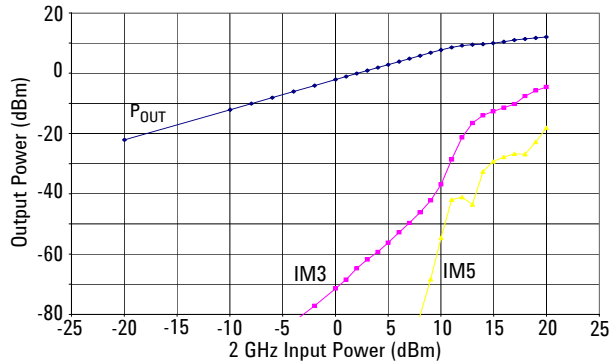

Figure 13.
Intermod Products vs. Input Power
@ 2 GHz Input[†]

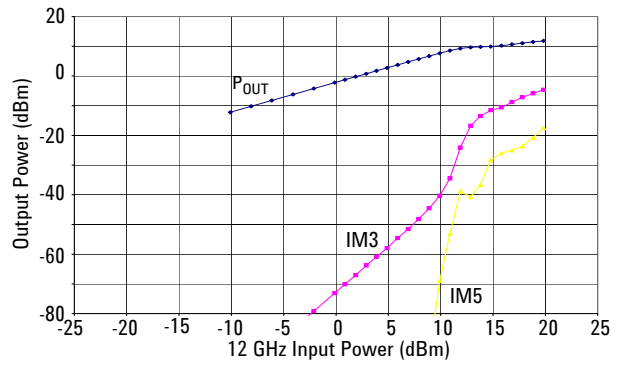

Figure 14.
Intermod Products vs. Input Power
@ 12 GHz Input[†]

[†] All data was measured on-wafer with a wafer probe system at
 $T_A=25^\circ\text{C}$.

This data sheet contains a variety of *typical* and guaranteed performance data. The information supplied should not be interpreted as a complete list of circuit specifications. Customers considering the use of this, or other MWTC GaAs ICs, for their design should obtain the current production specifications from MWTC Marketing. In this data sheet the term *typical* refers to the 50th percentile performance. For additional information contact MWTC Marketing at 1-577-4482.