

# Agilent N4371A RIN Measurement System

- ▲ *Accurate, high-speed and easy measurements of RIN frequency characteristics*
- ▲ *Reduced uncertainty by using Agilent original characterization technique*
- ▲ *High-speed measurement (5 seconds or less for 20 GHz span, 2000 points 10X average)*
- ▲ *Analysis on multiple traces with variety of markers*

Agilent provides an accurate, high-speed and easy-to-use spectral RIN measurement system by integrating of a sensitive, low-noise optical receiver, an industry-standard X-series spectrum analyzer and a digital multimeter.

RIN (Relative Intensity Noise) is a parameter representing temporal intensity fluctuations of a laser signal and is used to characterize the noise of laser devices. RIN is an indispensable specification for indicating the signal quality of both digital and analog optical transmission systems.

The N4371A Agilent RIN measurement system provides accurate RIN measurements with a specially developed characterization technique Agilent's RIN measurement system also reduces uncertainties by precisely removing the interference from thermal noise and shot noise.

The measurement time is less than 5 seconds with the conditions of a 20 GHz frequency span, 2,000 frequency points and 10 times average. The high-speed measurement enables a real-time observation of RIN frequency characteristics with varying parameters of the DUT.

The user interface of the, N4371A, shown in Figure 2, is easily accessible from the spectrum analyzer display. The user interface provides functions

for displaying up to 5 traces, placing up to 5 markers and searching for minimum or maximum RIN values in specific frequency range.



Figure 1. N4371A RIN Measurement System

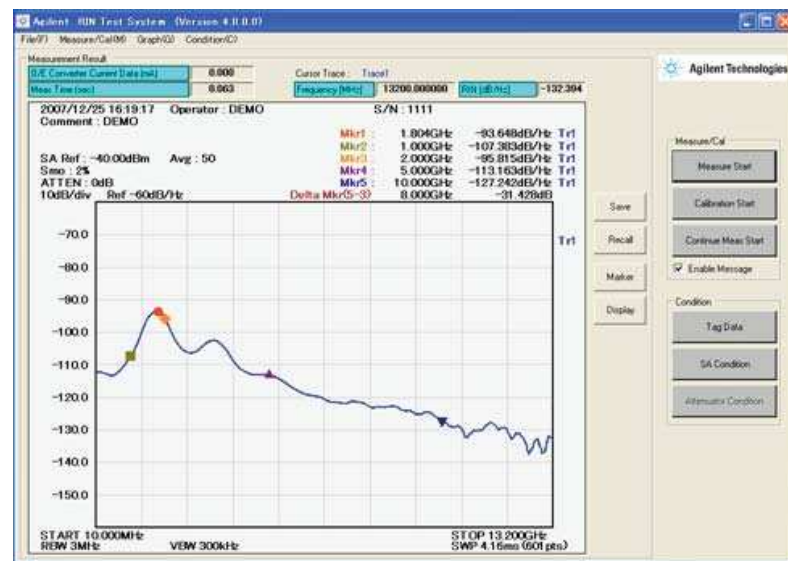

Figure 2. RIN Measurement User Interface

## System Configuration

### RIN Measurement System N4371A-301 (7G) or N4371A-302 (20G)

<b>Optical Receiver</b>	See Figure 3 Block Diagram
<b>System User Interface</b>	See Figure 2
<b>X-Series Spectrum Analyzer</b>	See Table 1
<b>Digital MultiMeter</b>	Agilent 34410A
<b>Options for input power control N4371-221(straight connector) or N4371A-222 (angled connector)</b>	
Optical attenuator	Agilent 81576A or 81577A
Optical multimeter mainframe	Agilent 8163B
GP-IB Interface	Agilent 82357B USB/GP-IB interface

Table 1 N4371A Frequency Range and Product Number of MXA-Series Spectrum Analyzer

Option	#301	#302
<b>Frequency Range</b>	10MHz to 6.7GHz	10MHz to 20GHz
<b>MXA Series Option</b>	N9020A-508 N9020-PFR	N9020A-526 N9020A-PFR

## System Block Diagram

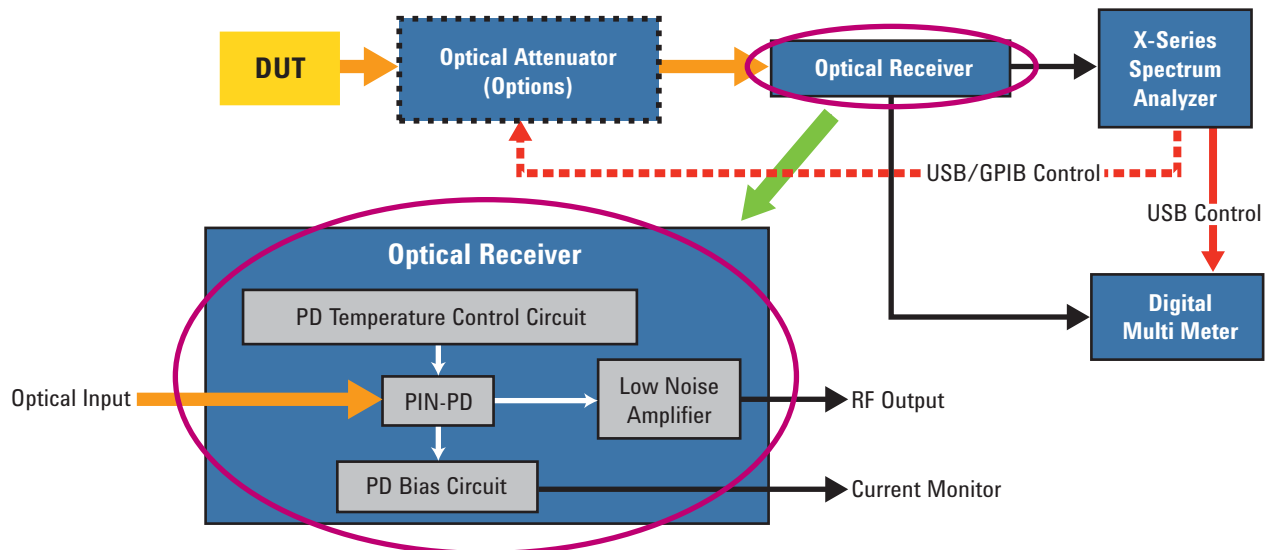

Figure 3. RIN Measurement System Block Diagram

## Measurement Example

In the RIN measurement system, an laser signal from the DUT is converted to an electric signal by the PIN-photodiode in the optical receiver. The electric signal is amplified by the low noise amplifier and measured with the spectrum analyzer. The average photocurrent of the PIN-PD is monitored by the digital multimeter.

The amplified electric signal contains thermal noise and shot noise as well as laser intensity noise. The RIN measurement isolates the amplified laser intensity noise from other noise components. The shot noise is calculated from the average photocurrent and the thermal noise is obtained as a noise without laser signal. The RIN measurement system calculates the laser intensity noise current before amplification using the factory calibration data of the photoelectric frequency response of the system. The accuracy of the photoelectric frequency response significantly affects the measurement results. Agilent characterizes the response value precisely by an originally developed methodology. The RIN value is derived from the laser intensity noise current and the average photocurrent.

The measurement results are saved as tabular data of the frequency and the RIN value in CSV file format and as graphical profiles in PNG file format.

Optionally an 81576A or 81577A optical attenuator, 8163B optical multimeter mainframe and 82357B USB/GP-IB interface can be included in the system configuration, if input optical power control is required for more than 10 dBm optical source power.

Figure 4 shows a RIN measurement example of a 1550nm DFB-laser. The RIN measurement system provides accurate, fast and easy RIN measurement to a very low RIN value to -160dB/Hz or

less, in a wide frequency range from 10MHz to 20GHz.

The smoothing aperture is selectable from 0% to 10% for displaying the measurement results. This function

achieves a high resolution RIN evaluation with small smoothing aperture, which shows the full frequency dependence of the RIN characteristics.

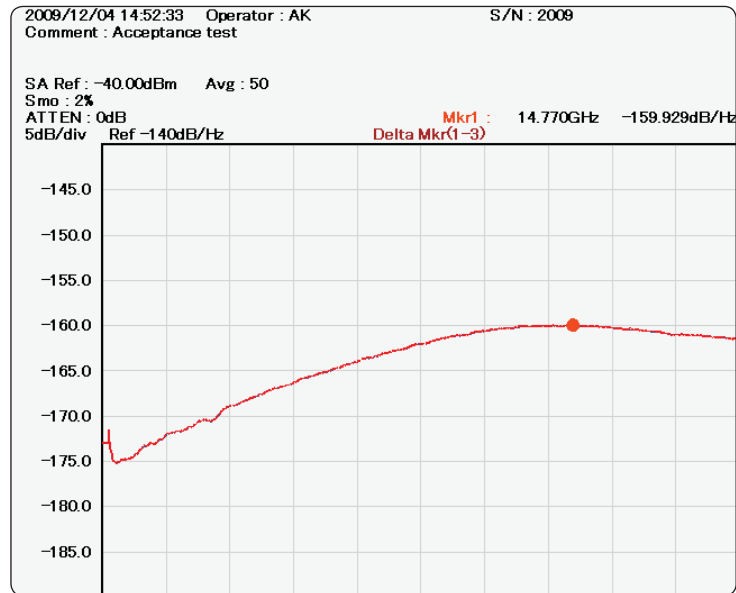

Figure 4. RIN Measurement Example

## System Performance Characteristics

Parameter	Min.	Nom.	Max.	Option
<b>Wavelength Range</b>	1265nm	1550nm	1625nm	
<b>Frequency Range</b>	10 MHz		7 GHz	301
			20 GHz	302
<b>Minimum RIN Measurement Value<sup>1</sup></b>	-160dB/Hz			
<b>Optical Power Range<sup>2</sup></b>				10 dBm
<b>Operating Temperature</b>	+15°C		+35°C	
<b>Humidity<sup>3</sup></b>	20%RN		80%RN	
<b>Operating Altitude</b>				2000 m

1. 1550 nm, 0 dBm input to optical receiver, 5% smoothing; The “Minimum RIN Measurement Value” specification is defined such that when this RIN value of -160 dB/Hz is measured on a +10dBm signal, then the measured RIN value when the signal is attenuated to 0dBm is the same within a deviation of -2.2 to 1.4 dB.
2. Input to the optical receiver
3. From +15 to +35°C



### Agilent Email Updates

[www.agilent.com/find/emailupdates](http://www.agilent.com/find/emailupdates)

Get the latest information on the products and applications you select.



[www.lxistandard.org](http://www.lxistandard.org)

LXI is the LAN-based successor to GPIB, providing faster, more efficient connectivity. Agilent is a founding member of the LXI consortium.

### Agilent Channel Partners

[www.agilent.com/find/channelpartners](http://www.agilent.com/find/channelpartners)

Get the best of both worlds: Agilent's measurement expertise and product breadth, combined with channel partner convenience.

## Remove all doubt

Our repair and calibration services will get your equipment back to you, performing like new, when promised. You will get full value out of your Agilent equipment throughout its lifetime. Your equipment will be serviced by Agilent-trained technicians using the latest factory calibration procedures, automated repair diagnostics and genuine parts. You will always have the utmost confidence in your measurements.

Agilent offers a wide range of additional expert test and measurement services for your equipment, including initial start-up assistance, onsite education and training, as well as design, system integration, and project management.

For more information on repair and calibration services, go to:

[www.agilent.com/find/removealldoubt](http://www.agilent.com/find/removealldoubt)

## [www.agilent.com](http://www.agilent.com)

For more information on Agilent Technologies' products, applications or services, please contact your local Agilent office. The complete list is available at:

[www.agilent.com/find/contactus](http://www.agilent.com/find/contactus)

### Americas

Canada	(877) 894-4414
Latin America	305 269 7500
United States	(800) 829-4444

### Asia Pacific

Australia	1 800 629 485
China	800 810 0189
Hong Kong	800 938 693
India	1 800 112 929
Japan	0120 (421) 345
Korea	080 769 0800
Malaysia	1 800 888 848
Singapore	1 800 375 8100
Taiwan	0800 047 866
Thailand	1 800 226 008

### Europe & Middle East

Austria	43 (0) 1 360 277 1571
Belgium	32 (0) 2 404 93 40
Denmark	45 70 13 15 15
Finland	358 (0) 10 855 2100
France	0825 010 700*
	*0.125 €/minute
Germany	49 (0) 7031 464 6333
Ireland	1890 924 204
Israel	972-3-9288-504/544
Italy	39 02 92 60 8484
Netherlands	31 (0) 20 547 2111
Spain	34 (91) 631 3300
Sweden	0200-88 22 55
Switzerland	0800 80 53 53
United Kingdom	44 (0) 118 9276201

Other European Countries:

[www.agilent.com/find/contactus](http://www.agilent.com/find/contactus)

Revised: October 1, 2009

Product specifications and descriptions in this document subject to change without notice.

© Agilent Technologies, Inc. 2007, 2008, 2009  
Printed in USA, December 17, 2009  
5989-7300EN



Agilent Technologies