



Agilent Technologies N5465A: InfiniiSim Waveform Transformation Toolset for the Infiniium Series Oscilloscopes

Data Sheet



The Agilent Technologies Inc. InfiniiSim waveform transformation toolset software for the 9000, 90000 and 90000 X Series oscilloscopes provides the most flexible and accurate means to render waveforms anywhere in a digital serial data link. The highly configurable system modeling that is featured enables engineers to remove the deleterious effects of

unwanted channel elements, simulate waveforms with channel models inserted, view waveforms in physically unprobable locations, compensate for loading of probes and other circuit elements, and to do so simply and quickly on the digital engineers tool of choice, the real-time oscilloscope.



Agilent Technologies

Use models for productivity and margin

The InfiniiSim waveform transformation toolset provides default configurations for many common use models as well as general purpose configurations for the advanced user. These are identified and described as follows:

1. **Removal of channel element insertion loss (Advanced and Basic)**

Description: one block of loss such as from a cable or fixture between a digital source and the oscilloscope. The inverse gain of the block (S_{21}^{-1}) is determined and its time response is convolved with the acquisition.

2. **Inserting a channel element insertion loss (Advanced and Basic)**

Description: one block of loss such as from a standard cable model to be inserted before the oscilloscope. The S_{21} of the block is determined and its time response is convolved with the acquisition.

3. **Remove all effects of a channel element (Advanced only)**

Description: Using S-parameter models of source and scope load, the effects of a channel element are totally removed. This is different from 1 above (removing insertion loss) in that the interactions between the elements are taken into account. This provides the most accurate way to remove a channel element.

4. **Add all effects of a channel element (Advanced only)**

Description: Using S-parameter models of source and scope load with, a complete insertion of a channel element is performed. This is different from the Inserting a channel element insertion loss (#2 above) in that the reflective interactions between the elements are taken into account. This provides the most accurate rendering to insert a channel element such as a standard cable.

5. **Measurement plane relocation (Advanced only)**

Description: Measurement plane relocation allows you to view any voltage waveform in a circuit as the circuit exists by moving the simulation node to any location you desire. This is an 'in situ' analysis so is not a 'removal' or 'insertion' viewpoint.

6. **Remove loading effects of oscilloscope probe (Advanced only)**

Description: To remove the loading effects of a probe, a topology of circuit blocks is given that allows probe models to be considered in the measurement. An oscilloscope probe, while it might be defined as 'high impedance', really does have a loading effect on the circuit. This effect can be taken into account and removed.

7. **General purpose configuration (Advanced only)**

Description: General topologies are provided for greater flexibility. General purpose probe, 6 block, and 9 block topologies are available with user defined measurement and simulation points and each block can be defined as having combinations of up to three elements in cascade or parallel arrangement so 27 total circuit elements can be defined for the most sophisticated scenarios.

Model your system as detailed as you need

InfiniiSim waveform transformation toolset offers a wide breadth of possibilities to suit your goals:

One block for simplest path compensation

Many times you will want simply to compensate for the loss of a channel element such as a cable or fixture. The one block model shown right gets this job done. It can also be extended to a remove/replace operation by changing simulation parameters.

Three block analysis for true channel element removal and insertion

When the most precision is required for a single channel element removal and insertion is required you will need at least the 3 block model. This model uses block descriptions for transmitter (T) and receiver (S) as well as the channel (C) to describe the full system. The inclusion of the transmitter and receiver blocks enable most complete waveform rendering by including the reflective S-parameter elements in the mathematical calculation of the transfer function used to transform from the measurement, M to the simulated measurement, S.

General Purpose Configurations

The InfiniiSim waveform transformation toolset includes 3 general purpose topologies to enable detail tailoring of the description of your circuit. For probe modeling, the general purpose probe topology is used while for SMA differential probe usage, the general purpose 6 block model will find use in a majority of cases. For those very sophisticated applications, possibly using both high impedance probes and differential SMA probe heads, the general purpose model can be used to describe these complex cases.

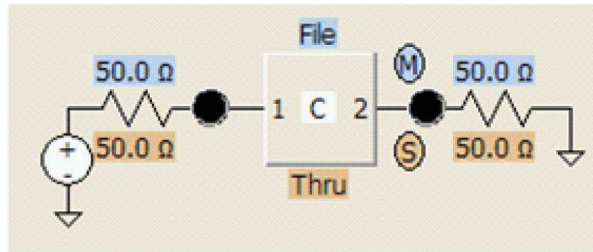

Figure 1. One Block Channel Element

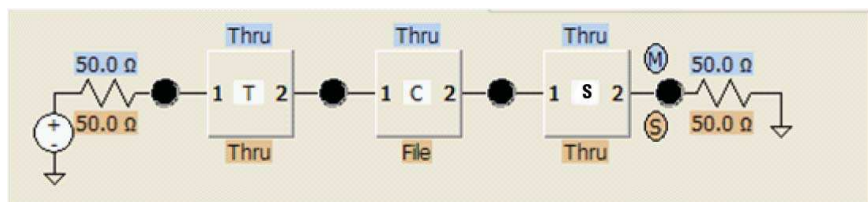

Figure 2. Three block analysis for channel element insertion

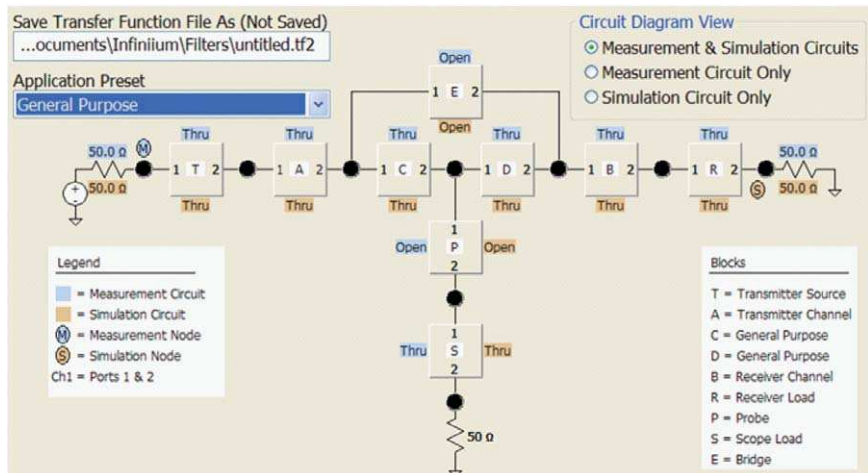

Figure 3: InfiniiSim can handle the most sophisticated system configurations with the general purpose configuration shown above.

Model your system as detailed as you need

Circuit models to define your setup

The InfiniiSim waveform transformation toolset provides a graphical user interface for you to define your system as you understand it and can be almost arbitrarily complex. This is accomplished through topology selection and circuit block definition. The most common circuit block definition is that of an S-parameter model which can be measured directly using a vector network analyzer, be derived from a time domain reflectometer with appropriate conversion software, or be created from a simulation tool such as the Advanced Design System. S-Parameters can be entered as two port models (.s2p files) or as 4 port models (.s4p files). Circuit descriptions such as R-L-C definition or 'open' and 'thru' are also available as are more complex blocks that result from cascaded or parallel combinations of circuit elements. The InfiniiSim waveform transformation software makes AC small signal linearity assumptions to derive transfer functions from an actual measured location (node) to another location that where you aim to simulate measurement. This location may physically exist but be unprobable, or may incorporate a circuit model not actually present. The transfer function is used to derive a time domain 'filter' that is convolved with the acquisition to transform the acquired waveform to a waveform at the desired location.

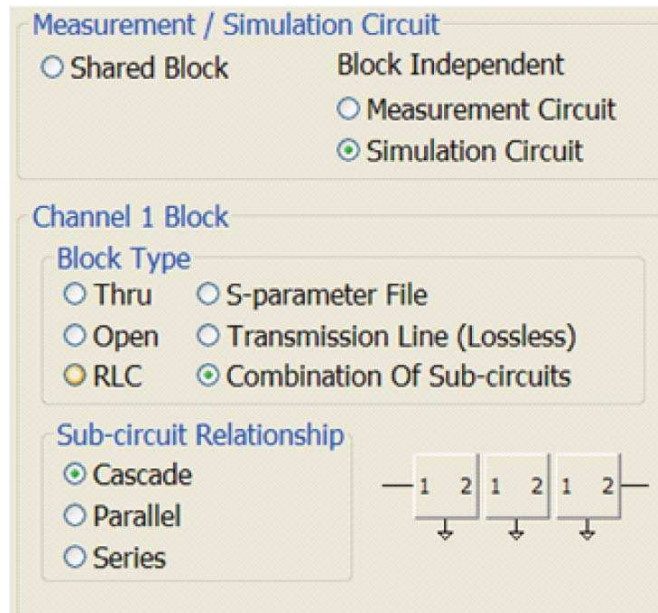

Figure 4. Measurement/simulation circuit

Model your system as detailed as you need

Measurement and simulation circuits

The core of the InfiniiSim waveform transformation software is in defining two circuits: one that defines your measurement setup and the other to define what you desire to have as your measurement. The first we call the 'measurement circuit' and the second is the 'simulation circuit'. These can be as simple as one block between the source and the oscilloscope load, or as complex as nine circuit blocks as in general purpose model. The simulation and measurement circuits share the topology selected, however, in many cases, circuit definitions for each block will be very different from measurement to simulation. This leads to great flexibility in transforming acquisitions at a measurement point to any other virtually probed location. For the circuit shown in Figure 5, for instance, Block 'P' has an S parameter file describing its loading during measurement, however, for simulation, the loading is desired to be eliminated, thus the 'open' designation.

See what you deserve to see

With the InfiniiSim waveform transformation toolset, you can see transformed signals in confidence whether channel elements are being inserted removed or whether the measurement plane is being relocated. Figure 6A below shows a waveform of a digital signal at 2.7 Gbs going through a combination of fixture and cable. Note that for the longer sequences of identical digits the waveform reaches a level that very different from when the data changes frequently. This is called ISI and is seen when the channel exhibits low pass filter characteristics. The fixture and cables were measured with a 4-port Vector Network Analyzer and removed using the channel element removal selection in InfiniiSim.

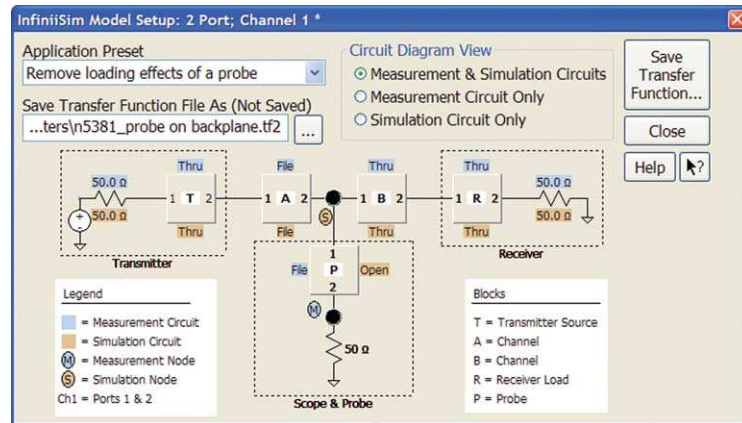

Figure 5. Measurement and Simulation circuits. Blue designates the measurement circuit elements while the brown labeling designates the simulation circuit elements.

Figure 6B depicts the results. Note the inset picture depicting the 'before measurement' directly at the transmitter versus the waveform in Figure 6A transformed using the 4-port channel model of the fixture.

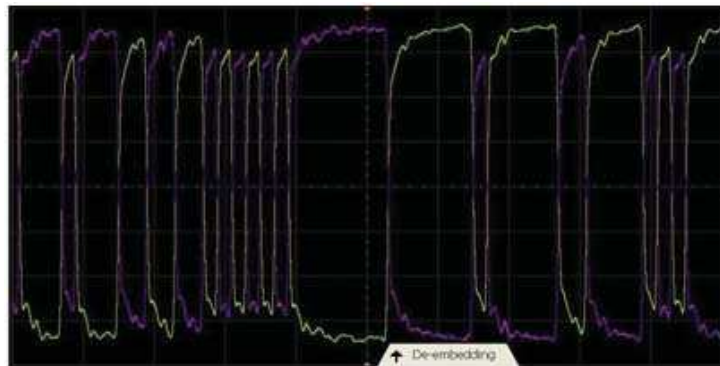

Figure 6A. Waveform before de-embedding the fixture

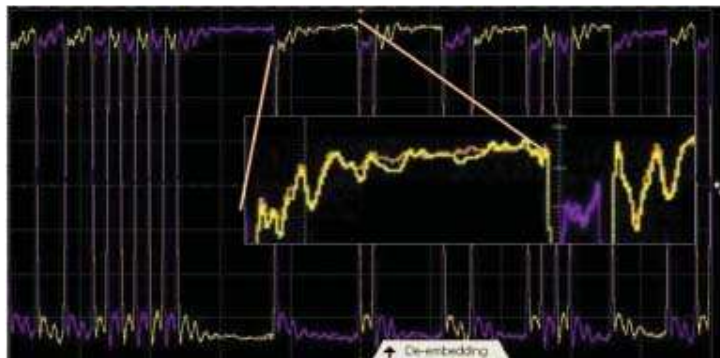

Figure 6B. After de-embedding and comparison to source signal. Source signal in orange and De-embedded signal in yellow.

Ordering information

To purchase the InfiniiSim waveform transformation toolset software for your new 9000, 90000 or 90000 X Series oscilloscope, order the following:

Model number	Description
DSA90000A or DSAX90000A	Infiniium 90000A or 90000 X Series scope with software 2.10 or higher
Opt 13	InfiniiSim waveform transformation toolset BASIC
Opt 14	InfiniiSim waveform transformation toolset ADVANCED
DSA9000A	Infiniium 9000A Series scope with software 2.00 or higher
Opt 13	InfiniiSim waveform transformation toolset BASIC
Opt 14	InfiniiSim waveform transformation toolset ADVANCED

For existing Infiniium 9000, 90000 or 90000 X Series oscilloscopes, update to software 2.10 or higher and order:

Model number	Description
N5465A-001	InfiniiSim Waveform Transformation Toolset BASIC
N5465A-002	InfiniiSim Waveform Transformation Toolset ADVANCED
N5435A-026	InfiniiSim Waveform Transformation Toolset BASIC Server Based License
N5435A-027	InfiniiSim Waveform Transformation Toolset ADVANCED Server Based License

Related literature

Publication title	Publication type	Publication number
<i>Infiniium DSO90000 and DSA90000 Series Oscilloscopes</i>	Data sheet	5989-7819EN
<i>Infiniium 9000 Series Oscilloscopes 4-Port</i>	Data sheet	5990-3746EN
<i>Infiniium 90000 X-Series Oscilloscopes</i>	Data sheet	5990-5271EN
<i>4-Port TDR/VNA/PLTS</i>	Application note	5989-5764EN
<i>ABCs of De-Embedding</i>	Application note	5989-5765EN

For more information please go to www.Agilent.com/InfiniiSim/info

For copies of this literature, contact your Agilent representative or visit www.agilent.com/find/scope-apps

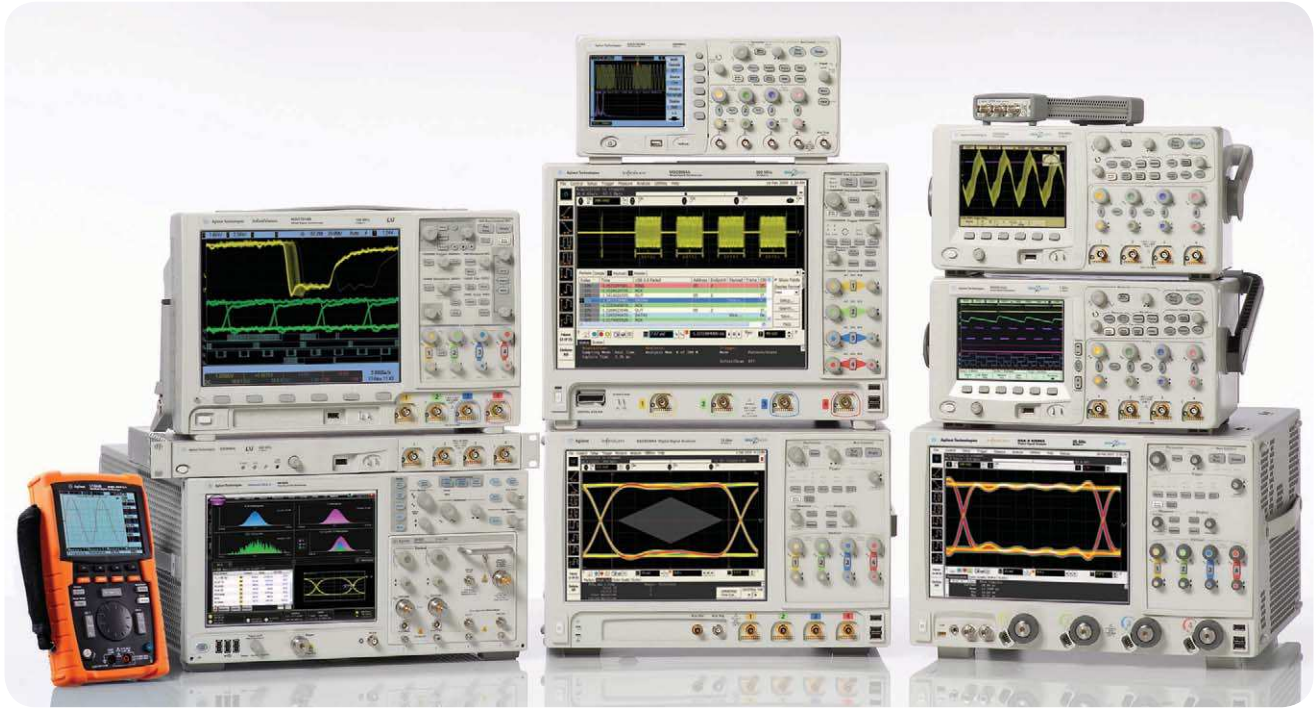

Agilent Technologies Oscilloscopes

Multiple form factors from 20 MHz to >90 GHz | Industry leading specs | Powerful applications



Agilent Email Updates

www.agilent.com/find/emailupdates

Get the latest information on the products and applications you select.



Agilent Direct

www.agilent.com/find/agilentdirect

Quickly choose and use your test equipment solutions with confidence.

Agilent Channel Partners

www.agilent.com/find/channelpartners

Get the best of both worlds: Agilent's measurement expertise and product breadth, combined with channel partner convenience.



www.lxistandard.org

LXI is the LAN-based successor to GPIB, providing faster, more efficient connectivity. Agilent is a founding member of the LXI consortium.

Windows® is a U.S. registered trademark of Microsoft Corporation.

Remove all doubt

Our repair and calibration services will get your equipment back to you, performing like new, when promised. You will get full value out of your Agilent equipment throughout its lifetime. Your equipment will be serviced by Agilent-trained technicians using the latest factory calibration procedures, automated repair diagnostics and genuine parts. You will always have the utmost confidence in your measurements.

Agilent offers a wide range of additional expert test and measurement services for your equipment, including initial start-up assistance onsite education and training, as well as design, system integration, and project management.

For more information on repair and calibration services, go to

www.agilent.com/find/removealldoubt

www.agilent.com

www.agilent.com/find/InfinitiSim

For more information on Agilent Technologies' products, applications or services, please contact your local Agilent office. The complete list is available at:

www.agilent.com/find/contactus

Americas

Canada	(877) 894-4414
Latin America	305 269 7500
United States	(800) 829-4444

Asia Pacific

Australia	1 800 629 485
China	800 810 0189
Hong Kong	800 938 693
India	1 800 112 929
Japan	0120 (421) 345
Korea	080 769 0800
Malaysia	1 800 888 848
Singapore	1 800 375 8100
Taiwan	0800 047 866
Thailand	1 800 226 008

Europe & Middle East

Austria	43 (0) 1 360 277 1571
Belgium	32 (0) 2 404 93 40
Denmark	45 70 13 15 15
Finland	358 (0) 10 855 2100
France	0825 010 700*
	*0.125 €/minute
Germany	49 (0) 7031 464 6333
Ireland	1890 924 204
Israel	972-3-9288-504/544
Italy	39 02 92 60 8484
Netherlands	31 (0) 20 547 2111
Spain	34 (91) 631 3300
Sweden	0200-88 22 55
Switzerland	0800 80 53 53
United Kingdom	44 (0) 118 9276201

Other European Countries:

www.agilent.com/find/contactus

Product specifications and descriptions in this document subject to change without notice.

October 1, 2009

© Agilent Technologies, Inc. 2010
Printed in USA, May 7, 2010
5990-4059EN



Agilent Technologies