



Agilent Signal Simulation Test System Z2090B-032

System Overview

System Capability

- RF signal generation for 50 MHz to 20 GHz
- Individual and combined RF carriers
- Spectrum Analysis and Vector Signal Analysis capabilities
- RF Power measurement capability to 26 GHz

System Software

The system comes with standard Agilent instrument drivers, measurement firmware depending on instrument options selected, Win XP Pro™ operating system, and Norton Ghost™.

System Hardware

- Two Agilent E8267D 20 GHz Performance Signal Generators with built in AWG capability
- Agilent E4440A Spectrum Analyzer
- Two Agilent N1912A RF Power Meters with wide band power sensors
- RF switch and signal conditioning chassis
- Internal 10 MHz reference distribution
- System rack, cabling, and industrial PC
- Modular DC power supply

Rack Hardware

- Agilent 1.6meter or 3rd party ruggedized rack, PDU and cooling

System Description

The Z2090B-032 Signal Stimulator Test Set (SSTS) provides generation and measurement of two individual and/or combined RF signals which are routed to one of four RF outputs. The RF signals are generated by two Agilent vector PSG signal generators which are capable of generating RADAR and communications signals from 50 MHz to 20 GHz. Measurement capability is provided by an Agilent PSA signal analyzer and an Agilent RF power meter.

Agilent will tailor the system to specific customer needs

Any test system is only as good as its capability to test the specific UUT. Agilent has the expertise, resources and processes in place to match the system to your needs. Our experience along with that of selected partners will ensure that your testing needs are fully met in a cost competitive manner.

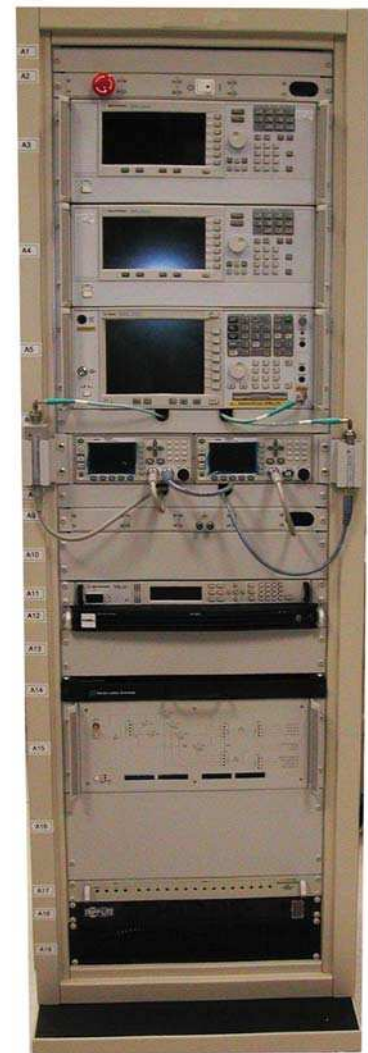

Rack example



Agilent Technologies

System Functional Block Diagram

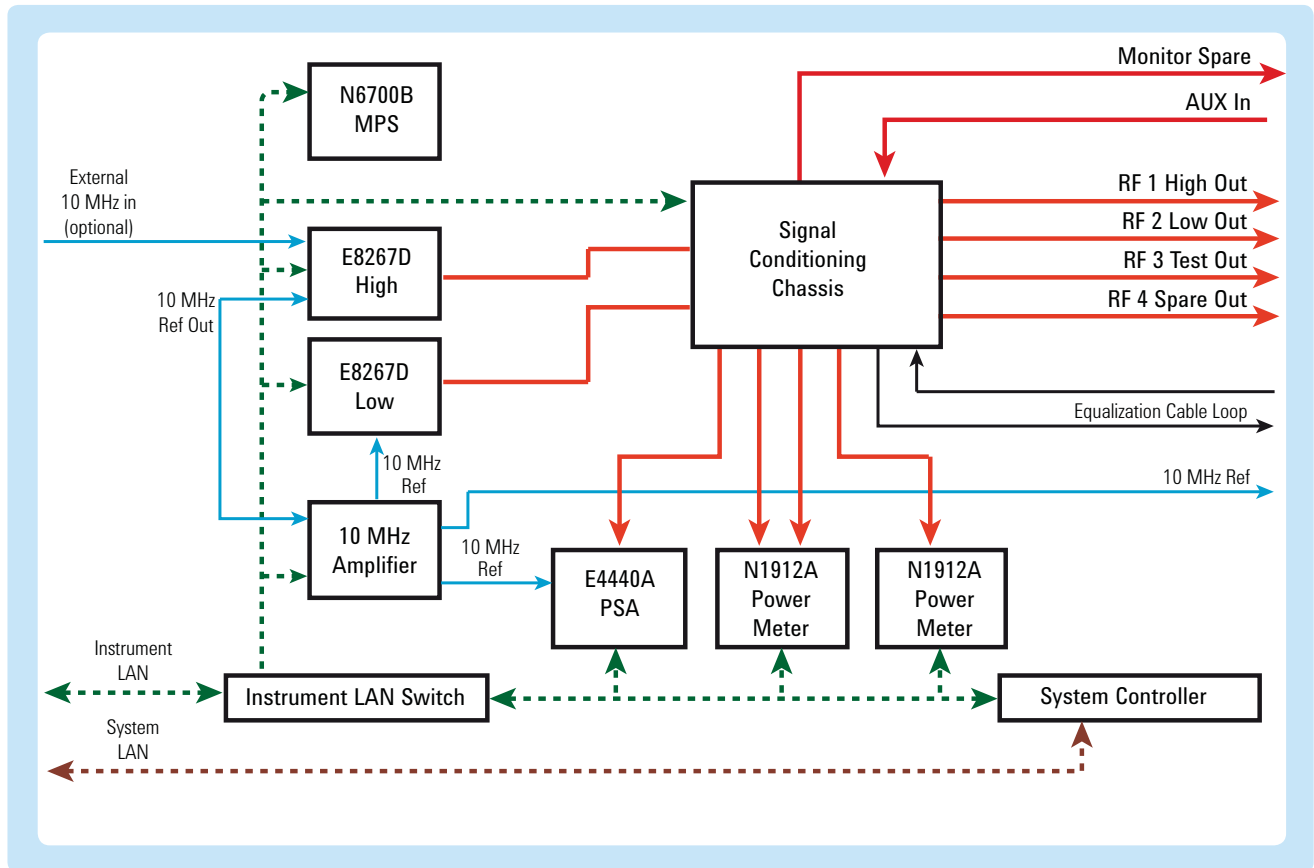

System Benefits

- This system solution provides a single part number with capability to supply RF stimulus and perform measurements for multiple channel communication and radar products
- SSTS is a platform solution that can be customized to specific requirements.

Warranty & Support

Agilent provides a 1-year return-to-Agilent warranty on custom systems. Warranty extensions and custom repair strategies are available to meet your specific requirements.

Agilent Technologies aims to maximize the value you receive, while minimizing your risk and problems. We strive to ensure that you get the test and measurement capabilities you paid for and obtain the support you need. Our extensive support resources and services can help you choose the right Agilent products for your applications and apply them successfully. Every instrument and system we sell has a global warranty. Support is available for at least five years beyond the production life of the product. Two concepts underlie Agilent's overall support policy: "Our Promise" and "Your Advantage."

Our Promise

Our Promise means your Agilent test and measurement equipment will meet its advertised performance and functionality. When you are choosing new equipment, we will help you with product information, including realistic performance specifications and practical recommendations from experienced test engineers. When you use Agilent equipment, we can verify that it works properly, help with product operation, and provide basic measurement assistance for the use of specified capabilities, at no extra cost upon request. Many self-help tools are available.

Application Assistance

Agilent's application experts are available to help optimize the system, taking full advantage of the system capability for your unique application. Operator training is also available to help you get the system into service quickly.

If your application goes beyond the standard system offering described above, Agilent program managers and engineering professionals can help define and implement unique functionality. They ensure that your custom system requirements are implemented successfully.



Agilent Email Updates

www.agilent.com/find/emailupdates

Get the latest information on the products and applications you select.



www.lxistandard.org

LXI is the LAN-based successor to GPIB, providing faster, more efficient connectivity. Agilent is a founding member of the LXI consortium.

Agilent Channel Partners

www.agilent.com/find/channelpartners

Get the best of both worlds: Agilent's measurement expertise and product breadth, combined with channel partner convenience.

Remove all doubt

Our repair and calibration services will get your equipment back to you, performing like new, when promised. You will get full value out of your Agilent equipment through-out its lifetime. Your equipment will be serviced by Agilent-trained technicians using the latest factory calibration procedures, automated repair diagnostics and genuine parts. You will always have the utmost confidence in your measurements. For information regarding self maintenance of this product, please contact your Agilent office.

Agilent offers a wide range of additional expert test and measurement services for your equipment, including initial start-up assistance, onsite education and training, as well as design, system integration, and project management.

For more information on repair and calibration services, go to:

www.agilent.com/find/removealldoubt

www.agilent.com

www.agilent.com/find/assist

For more information on Agilent Technologies' products, applications or services, please contact your local Agilent office. The complete list is available at:

www.agilent.com/find/contactus

Americas

Canada	(877) 894 4414
Latin America	305 269 7500
United States	(800) 829 4444

Asia Pacific

Australia	1 800 629 485
China	800 810 0189
Hong Kong	800 938 693
India	1 800 112 929
Japan	0120 (421) 345
Korea	080 769 0800
Malaysia	1 800 888 848
Singapore	1 800 375 8100
Taiwan	0800 047 866
Thailand	1 800 226 008

Europe & Middle East

Austria	43 (0) 1 360 277 1571
Belgium	32 (0) 2 404 93 40
Denmark	45 70 13 15 15
Finland	358 (0) 10 855 2100
France	0825 010 700*
	*0.125 €/minute
Germany	49 (0) 7031 464 6333
Ireland	1890 924 204
Israel	972-3-9288-504/544
Italy	39 02 92 60 8484
Netherlands	31 (0) 20 547 2111
Spain	34 (91) 631 3300
Sweden	0200-88 22 55
Switzerland	0800 80 53 53
United Kingdom	44 (0) 118 9276201

Other European Countries:

www.agilent.com/find/contactus

Revised: October 1, 2009

Product specifications and descriptions in this document subject to change without notice.

© Agilent Technologies, Inc. 2010

Printed in USA, May 26, 2010

5990-5916EN

Microsoft is a U.S. registered trademark of Microsoft Corporation.



Agilent Technologies