

Agilent 8500 FE-SEM

Compact System for Low-Voltage, High-Performance Imaging

Data Sheet



Features and Benefits

- Resolution and imaging equal to that of conventional FE-SEMs
- Variable low voltage eliminates charging and the need for sample coating
- Programmable X, Y, Z stage allows user to set precise coordinates, scan, and save information
- Miniature electrostatic lens design ensures repeatable performance without constant re-tuning
- Compact size enables easy installation in any research laboratory and does not require special facilities

Applications

- Polymers
- Thin films
- Biomaterials
- Nonconductive samples
- Energy-sensitive materials
- Glass substrates

Overview

The new Agilent 8500 FE-SEM offers researchers a field emission scanning electron microscope (FE-SEM) right in their own laboratory. This compact, innovative system has been optimized for low-voltage imaging, extremely high surface contrast, and resolution typically found only in much larger and more expensive field emission microscopes.

The 8500 is easy to install and use. No dedicated facilities are required, only an AC power outlet. About the size of a laser printer, the scientific-grade system provides capabilities to researchers in ordinary labs that previously were only available with conventional FE-SEMs installed in centralized facilities. The 8500 has been engineered to deliver consistent, reproducible performance and the industry's lowest total cost of ownership for a FE-SEM.



Agilent Technologies

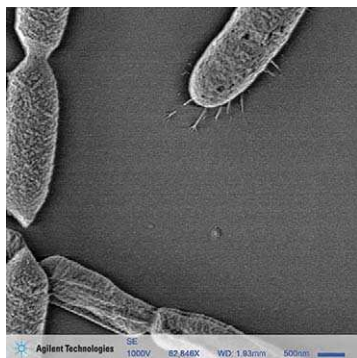

Figure 1. Bacillus megaterium incubated with L-mwaprin.

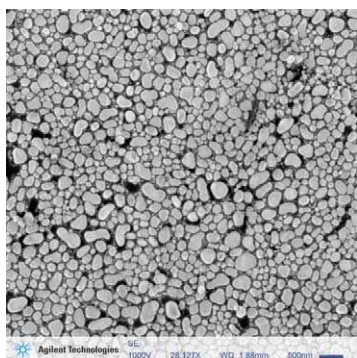

Figure 2. High resolution image of gold islands on carbon.

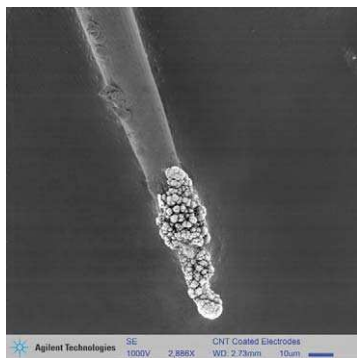

Figure 3. Low voltage image of uncoated electrode with CNTs on tip.

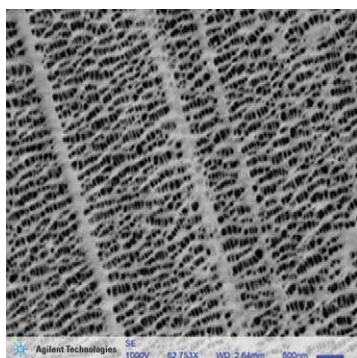

Figure 4. High resolution image of celgard.

Enhanced Imaging Capabilities

The 8500 FE-SEM offers several imaging techniques for enhancing surface contrast and allowing nanoscale features to be observed on a wide variety of nanostructured materials, including polymers, thin films, biomaterials, and other energy-sensitive samples on any substrate, even glass.

The system's continuously variable imaging voltage is tunable from 500 to 2000 volts as an operational parameter, rather than a setup choice. The 8500 eliminates charging of nonconductive samples without the need to coat the samples, which can mask nanoscale features, or resort to increased pressure operation, which can degrade resolution.

In addition, the 8500 utilizes a four-segment microchannel plate (MCP) detector that provides topographic imaging along two orthogonal directions to enhance surface detail. This technique has been demonstrated to clearly resolve sub-nanometer atomic steps on the surface of crystalline substances such as polytype 6H-SiC

Novel Design

The core technology inside a scanning electron microscope is the electron beam column, which extracts, collimates, shapes, scans, and focuses the electron beam. A

conventional electron beam column relies on a combination of precision-machined electromagnetic and electrostatic elements to control the electron beam. The coils that form the critical elements are typically hand-wrapped by technicians to achieve uniform electromagnetic fields. Moreover, closed-loop cooling and sophisticated vibration isolation are often required at the system level to manage the high currents in the lenses and other elements. The resultant high-resolution electron beam column is both large and expensive.

Silicon-based microfabrication techniques enable Agilent Technologies to design and fabricate a miniature electrostatic electron beam column combined with a thermal field emission electron source. The 8500 FE-SEM design utilizes stacks of silicon on insulator to form all of the lenses, apertures, and deflectors in the electron beam column. Patented technology allows these electron beam columns to be built wafer-scale on 150 mm substrates. The columns are fabricated with the precise aperture diameters and repeatable alignment tolerances required to minimize aberrations that can degrade image quality.

The system's thermal field emission electron source, meanwhile, provides high brightness, high stability, small virtual source size, and low energy spread and long-lasting consistent performance. A quad-segmented MCP detector

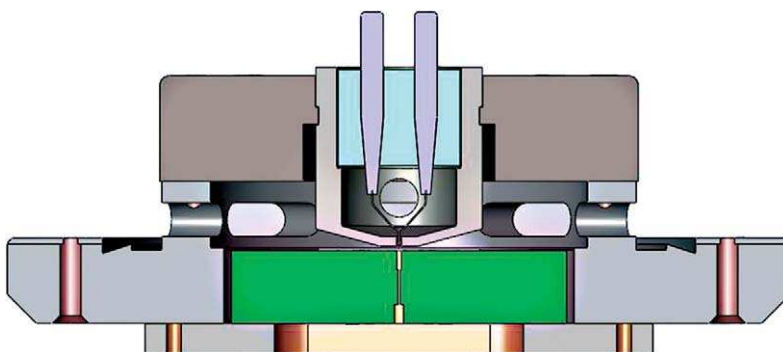

Schematic of electrostatic electron beam column.

is located just below the objective lens of the electron beam column directly and above the sample. This detector collects both backscattered and secondary electrons. The MCP may be operated either in a standard mode, where all the channels are added together, or in a differential mode (topographic mode), in which opposite sides of the detector are dynamically subtracted.

Performance Advantages

As described above, the 8500 FE-SEM embodies the successful miniaturization of the core technology in a scanning electron microscope. The 8500 is optimized for low-voltage imaging and sub-10 nm resolution. Its thermal field emission electron source provides high signal-to-noise ratios and consistent, long-lasting performance, while secondary and backscatter electron detection capabilities provide a rich data set for each sample.

Furthermore, the electrostatic lens design of the 8500 delivers repeatable performance without the constant re-tuning necessitated by the hysteresis in magnetic lenses found in conventional SEMs. This design allows researchers to store and return to any operating setup immediately with negligible fine adjustment, making the 8500 an ideal choice for multiple-user environments.

Ultimate Ease of Use

Just as the factory-calibrated 8500 FE-SEM is approximately the same size as a laser printer, it also offers similar plug-and-play performance. In fact, the compact size of the

8500 facilitates easy installation in practically any existing lab that has an AC power outlet.

Sample preparation and loading is both simple and fast. An X, Y, Z programmable stage lets users set specific coordinates, scan and then store the locations to repeat experiments with precision and confidence. For optimum control, the system's powerful software package features an intuitive graphical user interface (GUI) designed for novice and expert users.

The highly versatile 8500 can speed research and product development cycles by decreasing the time from experimentation to characterization. With the 8500, convenient access to FE-SEM performance is now a reality.

ECD Cartridge

The electron source, the electron beam column, and the electron detector of the 8500 FE-SEM are all combined in a field-replaceable ECD cartridge. When the long-lasting electron source is finally depleted, the entire ECD cartridge can be replaced on-site to provide the 8500 with not only a new source of electrons, but a new pre-aligned electron beam column and a new MCP detector — essentially a brand new FE-SEM.

Unlike conventional FE-SEMs, the electron source of the 8500 is easy to turn off and start up again quickly for imaging. By powering off the electron source when it is not in use, the lifetime of the source can be further extended, thus lowering the system operating costs and delivering the industry's lowest total cost of ownership for a FE-SEM.

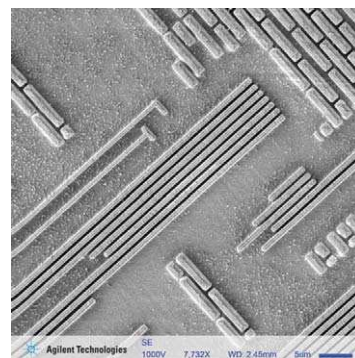

Figure 5. High resolution topographical surface information of de-processed chip metal conductor lines.

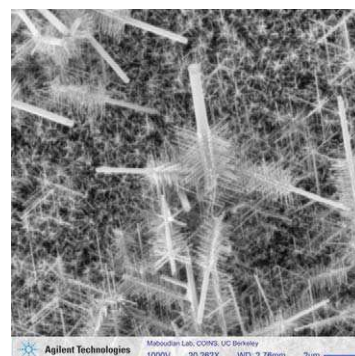

Figure 6. High resolution image of Si nanowires.

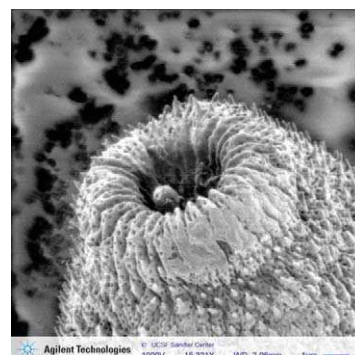

Figure 7. Low voltage image of uncoated *S. mansoni* parasite.

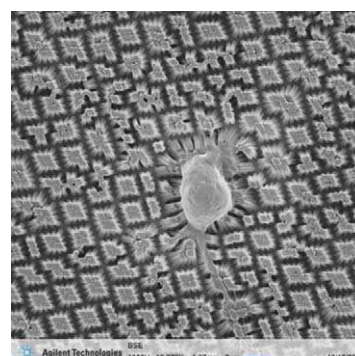

Figure 8. Uncoated cell image on PDMS pillars.

8500 Specifications

Performance	
Beam voltage	500 to 2000 V
Beam current	0.2 to 1 nA
Resolution	<10 nm at 1000 V
Magnification*	250 to 65,000 X
Digital zoom	10X
Scan field	1 x 1 mm (max)
Electron source	Schottky field emission
Detector modes	SE, BSE, Topo
Sample	
Sample size	100 x 60 mm (max)
Sample thickness	30 mm (max)
Viewable area	50 x 30 mm (max)
Sample mounts	Standard SEM stubs
Electrical activation	Vacuum feedthrough
System Control	
PC	Windows 7
Basic user interface	Simple image capture and controls
Expert user interface	Expert image optimization
Image	
Image formats	JPEG, TIFF, BMP, PNG
Image resolution	User selectable up to 2048 x 2048 pixels
Scan rate	Slow scan to video rate
Noise reduction	Frame and pixel averaging
Motorized Stage	
Piezo stage	1 μ m accuracy
X, Y, Z travel	50 x 50 x 10 mm
Vacuum System	
Chamber vacuum	1 e ⁻⁴ Torr
Pumpdown time	3 minutes
Turbo pump	80 liters per second
UHV pump	Ion pump with gettering
Dimensions	
Microscope	584(W) x 470(D) x 584(H) mm; 72 kg
Pump unit	203(W) x 254(D) x 203(H) mm; 4 kg
Installation Requirements	
Power	100/120/220-240 VAC; 50/60 Hz
Operating temperature	5 to 40°C
Humidity	20 to 80% RH
Compressed air	Not required
Dry nitrogen	Not required**
Water cooling	Not required

* Electron optical magnification relative to a 3nm pixel on a VGA monitor.
 ** A N₂ vent port is configured and available.

FE-SEM Instrumentation from Agilent Technologies

Agilent Technologies offers high-precision, compact FE-SEMs for research, industry, and education. Exceptional worldwide support is provided by experienced application scientists and technical service personnel. Agilent's leading-edge R&D laboratories are dedicated to the timely introduction and optimization of innovative and easy-to-use technologies.

Nanomeasurement Systems from Agilent Technologies

Agilent Technologies, the premier measurement company, offers high-precision, modular nanomeasurement solutions for research, industry, and education. Exceptional worldwide support is provided by experienced application scientists and technical service personnel. Agilent's leading-edge R&D laboratories ensure the continued, timely introduction and optimization of innovative, easy-to-use nanomeasure system technologies.

www.agilent.com/find/fe-sem

Americas

Canada	(877) 894 4414
Latin America	305 269 7500
United States	(800) 829 4444

Asia Pacific

Australia	1 800 629 485
China	800 810 0189
Hong Kong	800 938 693
India	1 800 112 929
Japan	0120 (421) 345
Korea	080 769 0800
Malaysia	1 800 888 848
Singapore	1 800 375 8100
Taiwan	0800 047 866
Thailand	1 800 226 008

Europe & Middle East

Austria	43 (0) 1 360 277 1571
Belgium	32 (0) 2 404 93 40
Denmark	45 70 13 15 15
Finland	358 (0) 10 855 2100
France	0825 010 700* *0.125 €/minute
Germany	49 (0) 7031 464 6333
Ireland	1890 924 204
Israel	972-3-9288-504/544
Italy	39 02 92 60 8484
Netherlands	31 (0) 20 547 2111
Spain	34 (91) 631 3300
Sweden	0200-88 22 55
Switzerland	0800 80 53 53
United Kingdom	44 (0) 118 9276201

Other European Countries:

www.agilent.com/find/contactus

Product specifications and descriptions in this document subject to change without notice.

© Agilent Technologies, Inc. 2012
 Printed in USA, October 31, 2012
 5990-6183EN RevB



Agilent Technologies