

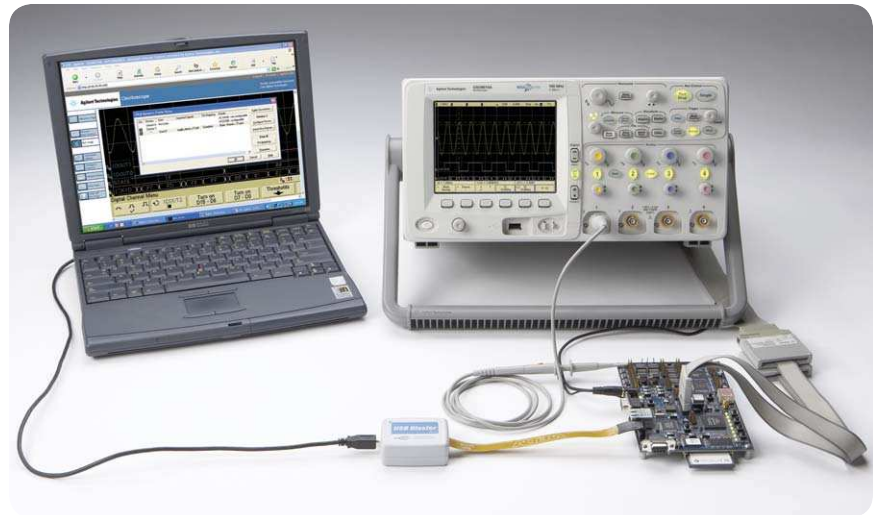

# Agilent Technologies InfiniiVision MSO N5434A FPGA Dynamic Probe for Altera

## Data Sheet



**Figure 1.** FPGA dynamic probe for Altera used in conjunction with an InfiniiVision 6000 or 7000 Series MSO provides an effective solution for simple through complex debugging of systems incorporating Altera FPGAs.

### The challenge

You rely on the insight a MSO (mixed-signal oscilloscope) provides to understand the behavior of your FPGA in the context of the surrounding system. Design engineers typically take advantage of the programmability of the FPGA to route internal nodes to a small number of physical pins for debugging. While this approach is very useful, it has significant limitations.

- Since pins on the FPGA are typically an expensive resource, there are a relatively small number available for debug. This limits internal visibility (i.e. one pin is required for each internal signal to be probed).
- When you need to access different internal signals, you must change your design to route these signals to the available pins. This can be time consuming and can affect the timing of your FPGA design.
- Finally, the process required to map the signal names from your FPGA design to the MSO digital channel labels is manual and tedious.
- When new signals are routed out, you need to manually update these signal names on the MSO, which takes additional time and is a potential source of confusing errors.



# Debug your FPGAs faster and more effectively with a MSO

## FPGA dynamic probe lets you:

**View internal activity** – With the digital channels on your MSO, you are normally limited to measuring signals at the periphery of the FPGA. With the FPGA dynamic probe, you can now access signals internal to the FPGA. You can measure up to 256 internal signals for each external pin dedicated to debug, unlocking visibility into your design that you never had before.

**Make multiple measurements in seconds** – Moving probe points internal to an FPGA used to be time consuming. Now, in less than a second, you can easily measure different sets of internal signals without design changes. FPGA timing stays constant when you select new sets of internal signals for probing.

**Leverage the work you did in your design environment** – The FPGA dynamic probe maps internal signal names from your FPGA design tool to your Agilent MSO. Eliminate unintentional mistakes and save hours of time with this automatic setup of signal and bus names on your MSO.

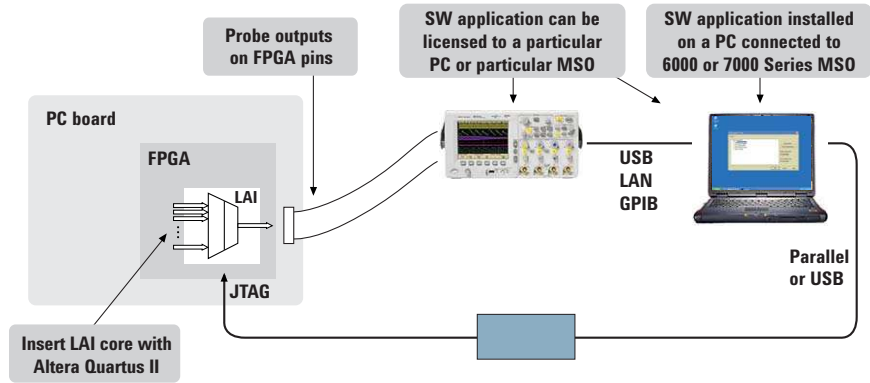

**Figure 2.** The FPGA dynamic probe requires Altera’s Quartus II design software with its LAI (logic analyzer interface) and Altera programming hardware setup. The Quartus II (ver. 6.0 or higher) LAI allows you to create and insert a debug core that interacts with the FPGA dynamic probe application on your MSO. The FPGA dynamic probe controls which group of internal signals to measure via the Altera programming hardware connected to the JTAG port of the FPGA.

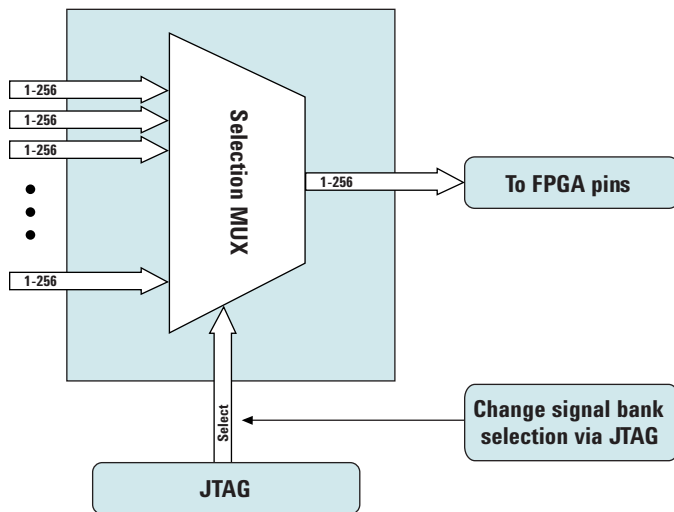
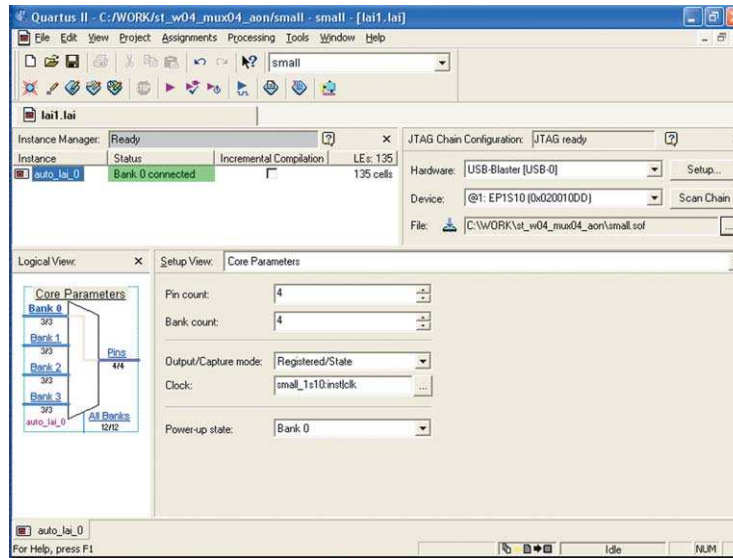

**Figure 3.** Access up to 256 internal signals for each debug pin. Signal banks all have identical width (1 to 256 signals wide) determined by the number of device pins you devote for debug. Each pin provides sequential access to one signal from every input bank. MSO6000 series can acquire up to 16 signals using digital channels.

# A quick tour of the application

## Design step 1: Configure the logic analyzer interface file and core parameters

You need to create a Altera LAI file with MSO in Quartus II. This file defines the interface that builds a connection between the internal FPGA signals and the MSO digital channels. You can then configure the core parameters, which include number of pins, number of signal banks, the type of measurement (state or timing), clock and the power-up state.



## Design step 2: Map the Altera LAI core outputs to available I/O pins

Use Pin Planner in Quartus II to assign physical pin locations for the LAI.

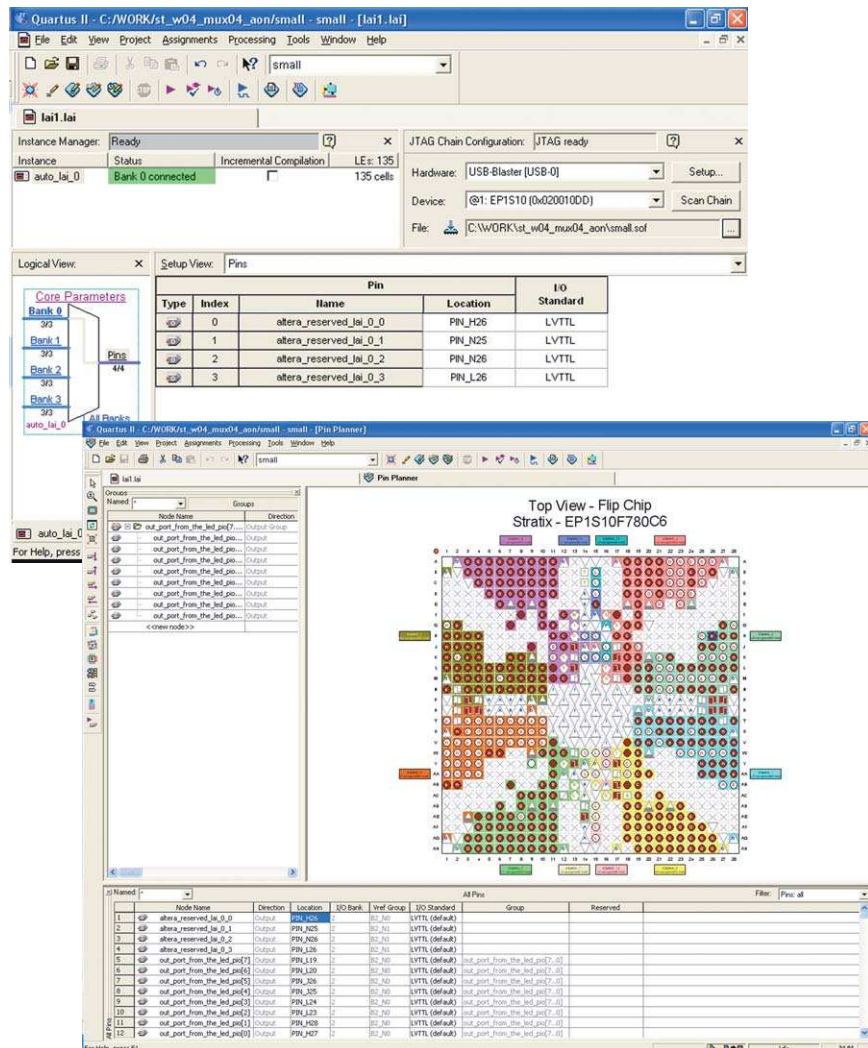

## A quick tour of the application (continued)

### Design step 3: Assign LAI bank parameters

Assign internal signals to each bank in the LAI after you have specified the number of banks to use in the core parameters. Find the signals you want to acquire with the Node Finder and assign them to the banks.

With the LAI core fully configured and instantiated into your FPGA design, you're ready to compile your design to create the device programming file (.sof). Then, to make measurements you'll move to the Agilent MSO with FPGA dynamic probe software.

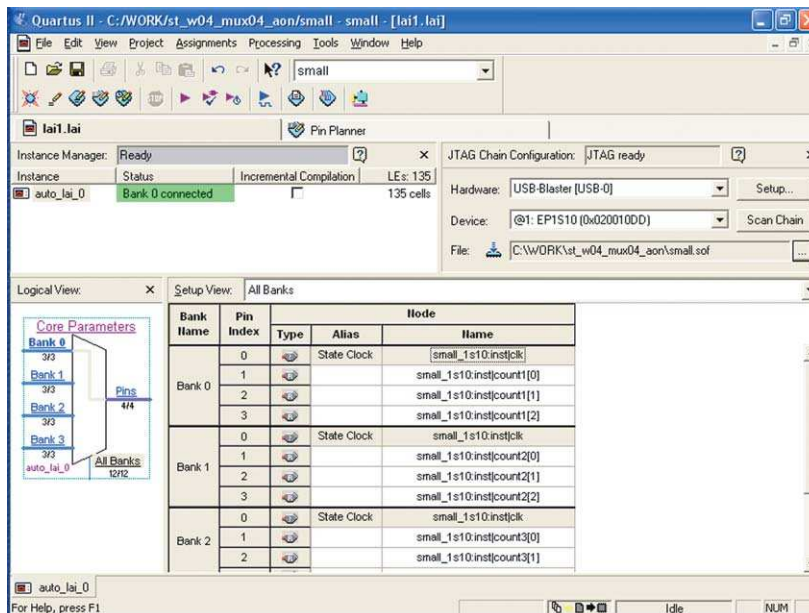

### Activate FPGA dynamic probe for Altera

The FPGA dynamic probe application allows you to control the LAI and set up the MSO for the desired measurements. This application runs on a PC.

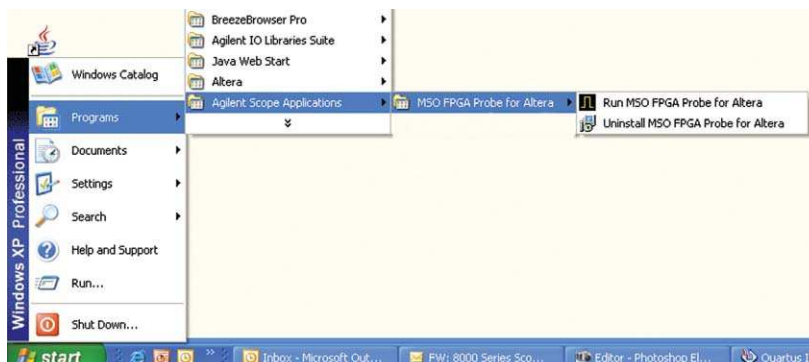

### Connect your MSO to your PC

From FPGA dynamic probe application software, specify the communication link between your PC and MSO.

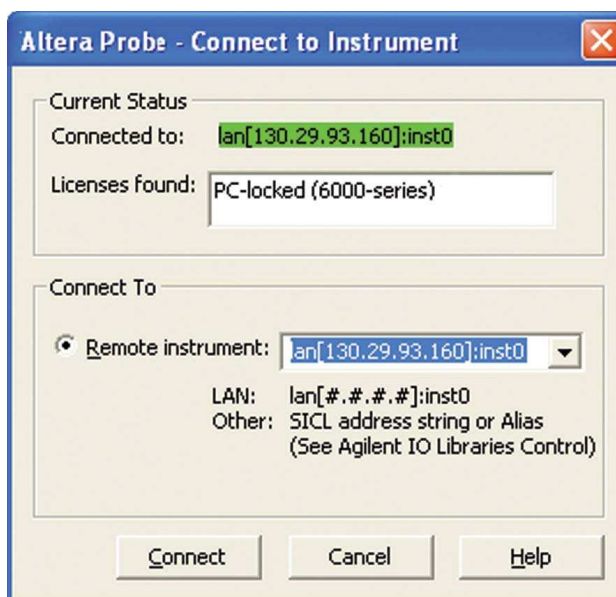

## A quick tour of the application (continued)

### Measurement setup step 1: Establish a connection between the MSO and the LAI

The FPGA dynamic probe application establishes a connection between the MSO and the FPGA via a JTAG cable. It also determines what devices are on the JTAG scan chain and lets you pick the one with which you wish to communicate.

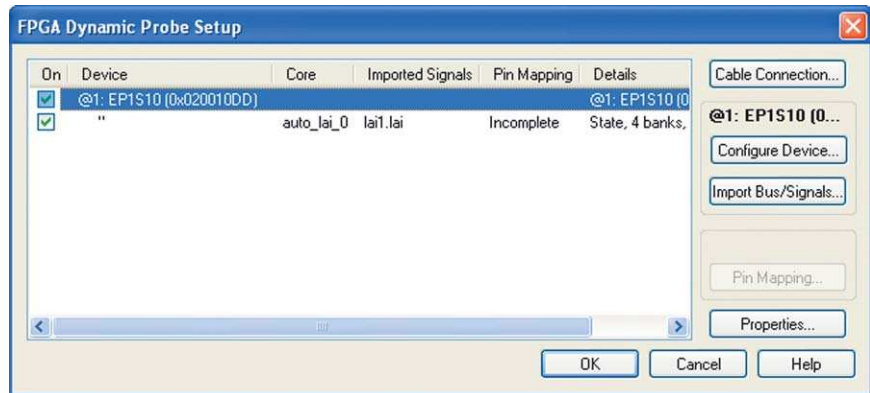

### Measurement setup step 2: Configure the device and import signal names

If needed, you can configure the device with the SRAM object file (.sof) that includes the logic analyzer interface file. The FPGA dynamic probe application reads a .lai file produced by Quartus II. The names of signals you measure will now automatically appear in the label names on your Agilent MSO.



### Measurement setup step 3: Map FPGA pins

Select your probe type and easily provide the information needed for the MSO to automatically track names of signals routed through the LAI file.

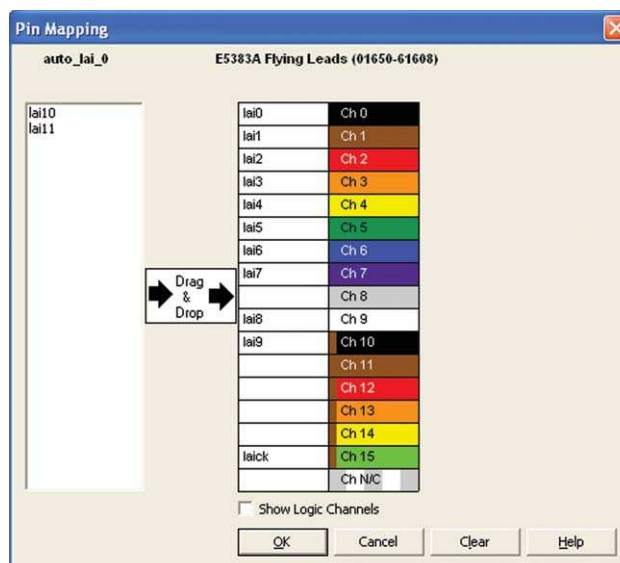

## A quick tour of the application (continued)

### Setup complete: Make measurements

Quickly change which signal bank is routed to the MSO. A single mouse click tells the LAI core to switch to the newly specified signal bank without any impact to the timing of your design. To make measurements throughout your FPGA, change signal banks as often as needed. With each new selection of a signal bank, FPGA Dynamic Probe updates new signal names from your design to the MSO. User-definable signal bank names make it straight forward to select a part of your design to measure.

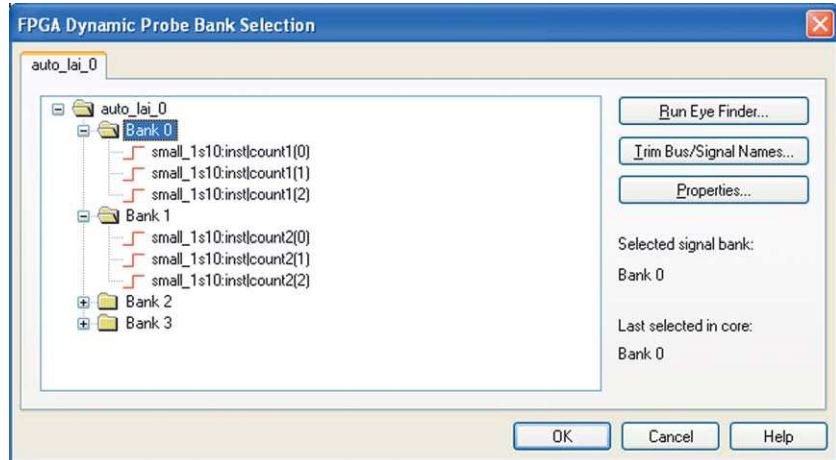

### Triggering on valid states

MSOs incorporate logic state triggering for triggering on specific states. Set up a valid state trigger by specifying the appropriate LAI clock edge and the desired bus/signal pattern. Because the LAI core outputs both the clock signal and bus values, triggering on the combination ensures your state trigger is valid—even though the digital channels are sampling asynchronously. Track valid states by measuring the bus value on each falling clock edge for the image shown.



### Correlate internal FPGA activity with external measurements

View internal FPGA activity and time-correlate internal FPGA measurements with external analog and digital events in the surrounding system. FPGA Dynamic Probe unlocks the power of the MSO for system-level debug with FPGAs.

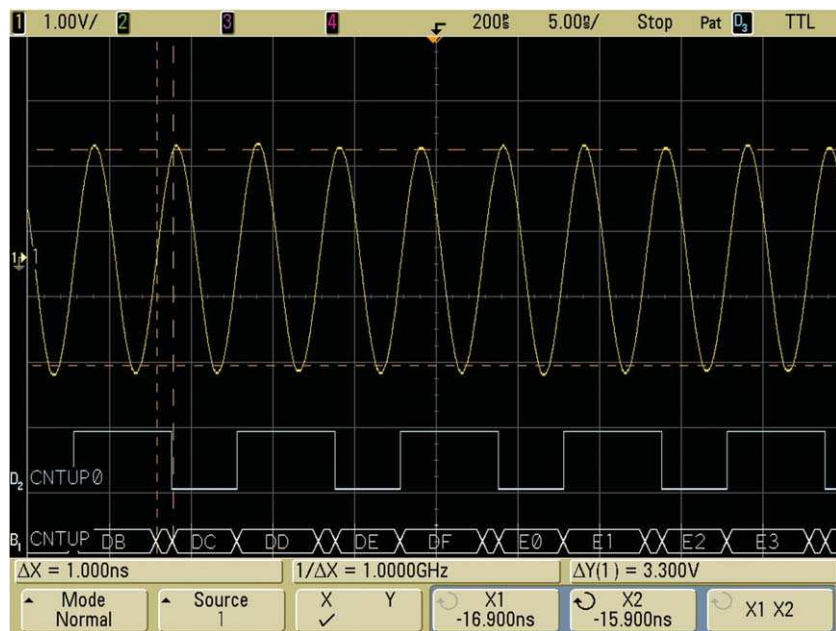

# Agilent N5434A specifications and characteristics

## Supported logic analyzers

|                                    |   |
|------------------------------------|---|
| Standalone oscilloscopes           | InfiniiVision 6000 and 7000 Series MSOs   |
| MSO Digital Channels               | 16  |
| Bus groupings                      | Up to 2, each with 6 character labels   |
| Triggering capabilities            | Determined by MSO, all have state triggering  |
| Supported Altera FPGA families     | All families that the Altera LAI core supports, including Stratix IV, Stratix III, Stratix II, Stratix, Cyclone III, Cyclone II, Cyclone, Arrix II and Arria  |
| Supported Altera cables (required) | Altera USB Blaster or ByteBlaster   |
| Supported probing mechanisms       | Soft touch (34-channel and 17-channel), Mictor, Samtec, Flying lead, 6000 and 7000 Series MSOs come standard with a 40 pin probe cable and flying leads. Cables and probing for Mictor, soft touch, or Samtec probing must be purchased separately. |

## Altera LAI characteristics

|                          |   |
|--------------------------|---|
| Number of output signals | User definable: 1 to 256 signals in 1 signal increments |
| Signal banks             | User definable: 1 to 256 banks                          |
| Modes                    | State (synchronous) or timing (asynchronous) mode       |

## Compatible software

|                                  |  |
|----------------------------------|--|
| Altera Quartus II 6.0 or greater | Agilent InfiniiVision 6000 and 7000 Series software version 4.0 or greater |
|----------------------------------|--|

Additional information available via the Internet: [www.agilent.com/find/6000-altera](http://www.agilent.com/find/6000-altera) and [www.agilent.com/find/7000-altera](http://www.agilent.com/find/7000-altera).

## Ordering information

### Ordering options for the Agilent N5434A FPGA dynamic probe for Altera

|            |  |
|------------|--|
| Option 001 | • Entitlement certificate for perpetual node-locked license locked to oscilloscope (most common) |
| Option 002 | • Entitlement certificate for PC locked license  |

## Related literature

| Publication title   | Publication type | Publication number |
|---|------------------|--------------------|
| <i>Frequently Asked Questions N5433A and N5434A Agilent MSO FPGA Dynamic Probe for Altera</i> | Data Sheet       | 5989-5957EN        |
| <i>Agilent Technologies 6000 Series Oscilloscopes</i>   | Data Sheet       | 5989-2000EN        |
| <i>Agilent Technologies InfiniiVision 7000 Series Oscilloscopes</i>                           | Data Sheet       | 5990-4769EN        |

## Product Web site

For the most up-to-date and complete application and product information, please visit our product Web site at: [www.agilent.com/find/7000](http://www.agilent.com/find/7000)



**Agilent Email Updates**

[www.agilent.com/find/emailupdates](http://www.agilent.com/find/emailupdates)

Get the latest information on the products and applications you select.



[www.lxistandard.org](http://www.lxistandard.org)

LXI is the LAN-based successor to GPIB, providing faster, more efficient connectivity. Agilent is a founding member of the LXI consortium.

**Agilent Channel Partners**

[www.agilent.com/find/channelpartners](http://www.agilent.com/find/channelpartners)

Get the best of both worlds: Agilent's measurement expertise and product breadth, combined with channel partner convenience.



Agilent Advantage Services is committed to your success throughout your equipment's lifetime. We share measurement and service expertise to help you create the products that change our world. To keep you competitive, we continually invest in tools and processes that speed up calibration and repair, reduce your cost of ownership, and move us ahead of your development curve.

[www.agilent.com/find/advantageservices](http://www.agilent.com/find/advantageservices)



[www.agilent.com/quality](http://www.agilent.com/quality)

For more information on Agilent Technologies' products, applications or services, please contact your local Agilent office. The complete list is available at:

[www.agilent.com/find/contactus](http://www.agilent.com/find/contactus)

**Americas**

|               |                |
|---------------|----------------|
| Canada        | (877) 894 4414 |
| Brazil        | (11) 4197 3500 |
| Latin America | 305 269 7500   |
| Mexico        | 01800 5064 800 |
| United States | (800) 829 4444 |

**Asia Pacific**

|           |                |
|-----------|----------------|
| Australia | 1 800 629 485  |
| China     | 800 810 0189   |
| Hong Kong | 800 938 693    |
| India     | 1 800 112 929  |
| Japan     | 0120 (421) 345 |
| Korea     | 080 769 0800   |
| Malaysia  | 1 800 888 848  |
| Singapore | 1 800 375 8100 |
| Taiwan    | 0800 047 866   |
| Thailand  | 1 800 226 008  |

**Europe & Middle East**

|                |                       |
|----------------|-----------------------|
| Austria        | 43 (0) 1 360 277 1571 |
| Belgium        | 32 (0) 2 404 93 40    |
| Denmark        | 45 70 13 15 15        |
| Finland        | 358 (0) 10 855 2100   |
| France         | 0825 010 700*         |
|                | *0.125 €/minute       |
| Germany        | 49 (0) 7031 464 6333  |
| Ireland        | 1890 924 204          |
| Israel         | 972-3-9288-504/544    |
| Italy          | 39 02 92 60 8484      |
| Netherlands    | 31 (0) 20 547 2111    |
| Spain          | 34 (91) 631 3300      |
| Sweden         | 0200-88 22 55         |
| Switzerland    | 0800 80 53 53         |
| United Kingdom | 44 (0) 118 9276201    |

Other European Countries:

[www.agilent.com/find/contactus](http://www.agilent.com/find/contactus)

Revised: July 8, 2010

Product specifications and descriptions in this document subject to change without notice.

© Agilent Technologies, Inc. 2010  
Printed in USA, July 26, 2010  
5989-5941EN

