

# Agilent 8762F Coaxial Switch 75 ohm

## Technical Overview



- DC to 4 GHz
- Exceptional repeatability over 1 million cycle life
- Excellent isolation



**Agilent Technologies**

The 8762F brings a new standard of performance to 75 ohm coaxial components. Designed for ATE switching systems, the 8762F offers the performance demanded by the cable television distribution equipment and communications equipment industries. It gives the ATE system designer of telecommunications and cable distribution equipment the tools to design reliable, high performance switching interfaces. The 8762F uses a mini 75 ohm SMB connector for the coaxial interface. The mini 75 ohm SMB connector is designed to terminate RG-179 75 ohm, coaxial cable. The 8762F is designed to work in virtually any system due to the range of voltage options covering 4.5 V to 30 V dc available for activating the switch solenoids. The standard configuration of the switch includes solder terminals.

The 8762F comes with current interrupt, the drive current is automatically disconnected after the switch is fully latched (30 ms).

As with its 50 ohm counterparts, the 8762A/B/C, the 8762F was designed for maximum dependability and performance. It has been designed to operate within its specifications for over 1 million cycles. In applications such as production test, maintaining a calibration is critical to assure accurate reliable measurements. To avoid frequent recalibration, switch repeatability is critical. Switch repeatability, especially in a test system switching interface, can contribute to test system uncertainty by adding random errors. Repeatability is controlled through a variety of factors including precise control of the switching structure and contact materials. The 8762F has a typical insertion loss repeatability, over 1 million cycles, of 0.03 dB at 25 °C.

### Interfacing to the 8762F

The 8762F uses a mini 75 ohm SMB connector. This connector has the same physical dimensions as a 50 ohm SMB, but has been optimized for 75 ohms. Sources for connectors are listed on page 6 of this technical overview.

### Computer-aided test systems

In automatic test systems, any of the switches can be driven directly by the 11713A attenuator/switch driver, so the switch becomes GPIB programmable. Each 11713A can drive up to ten 876X series switches.

### Portable and remote applications

Due to their small package size, light weight, lower power consumption, and high reliability, these switches are ideal for designing into your portable or remote applications. The light weight and repeatability make them well suited for portable spectrum analyzers and other portable microwave test equipment. Their 1,000,000 cycle life make them the ideal candidate for designing into systems, such as communications repeaters or remote monitoring stations that demand low service. The switch's automatic coil disconnect feature and low current drain during switching minimize the amount of power needed for operating the switches.

## Multisource switching

The 8762F is an excellent choice for applications that require selection of multiple signal sources, frequency counters, or signal control devices such as modulators or filters, or routing signals to multiple test ports as shown in Figure 1.

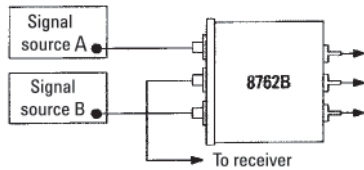

Figure 1. Multisource switching

## Easy GPIB programmability

The 8762F can be easily used in ATE systems with GPIB control using the 11713A, 70611A or 87130A attenuator/switch drivers. The 11713A has the capacity to drive up to ten 8762F switches. The 70611A and 87130A use a pulse drive method which allows them to drive up to 248 24V switches such as the 8762F.

## Operation and use

Switching is accomplished by applying a positive voltage to the common terminal and a negative voltage (or ground) to either pin #1 or #2 solenoid drive terminals (See Figure 2). Care should be taken to avoid simultaneously activating both terminals 1 and 2 as rapid cycling may occur.

All the switches are “break before make”; the switched ports are not connected to each other preventing possible damage to sensitive circuits. The standard configuration Option 8762F-024 for the switches uses 24 Vdc for the switching voltage. Option 8762F-011 specifies a voltage of 5 Vdc, and Option 8762F-015 specifies a switching voltage of 15 Vdc.

## Driver circuits

As mentioned above, activating the switches can be accomplished through the use of the 11713A attenuator/switch driver, providing pushbutton and GPIB control. In OEM applications, it may be desirable to design in a driver circuit. Figure 3 suggests an economical TTL compatible driver circuit for a standard 8762/3/4 family switch, using an IC relay driver and an inverter. A TTL “HI” input to the circuit connects ports 1 and common, and a TTL “LO” input connects ports 2 and common. This provides a complementary driver for the switch which ensures that only one coil of the switch can be activated at a time.

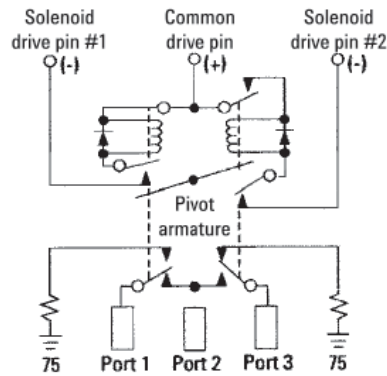

Figure 2. 8762

## Remote indication

The position of the switch may be determined by utilizing the open and closed states of the internal coil contacts. Figure 3 displays two indicator circuits, one to provide a TTL output and one that directly activates an LED. The circuits will output a TTL "HI" and LED "ON" if port 1 and port C are connected (note that port 2 and port C are connected; port 2 solenoid contacts will be open, port 1 solenoid contacts will be closed.) Due to the transient suppression circuits inside the switches, some precautions must be noted:

1. If the solenoids are pulsed, the indicator circuit will take approximately 1 second to settle to its steady state indication. This time delay can be reduced if the solenoid drive pulse is at least 250 milliseconds long. After this time, the indication will be correct.
2. The circuits shown are designed to operate with coil voltage of 24 V. If other voltage switches are used, the circuit components must be modified to accommodate that voltage.

Since current is drawn through the solenoid for these indicator circuits, inadvertent switching is prevented by limiting the current to 5 mA. Additional design information may be required from the component manufacturer for the circuits described in Figure 3, since modifications may be necessary, depending upon specific applications.

Agilent Technologies assumes no responsibility for use of any circuits described herein, and makes no representations or warranties, expressed or implied, that such circuits are free from patent infringements.

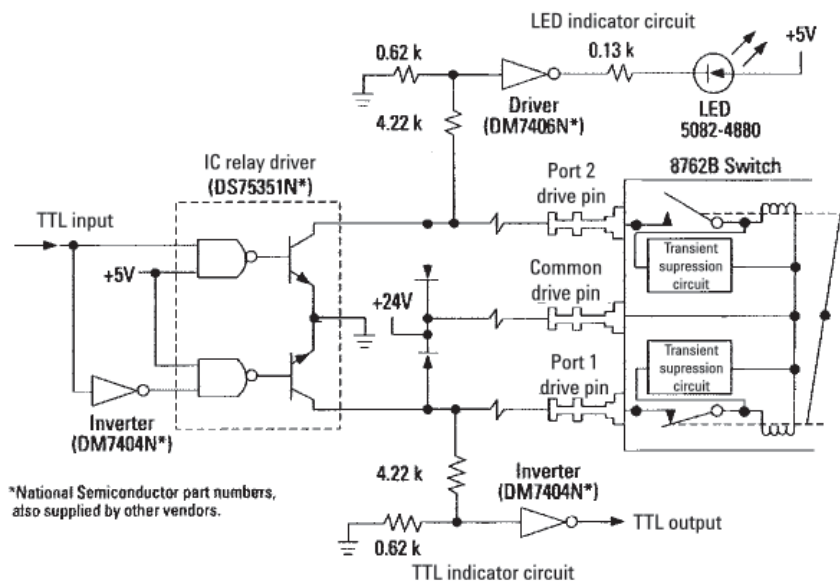

Figure 3. Driver circuit with remote indicator circuits

## Specifications

Specifications describe the instrument's warranted performance. Supplemental and typical characteristics are intended to provide information useful in applying the instrument by giving typical, but not warranted performance parameters.

Model number	8762F
Frequency range	dc to 4 GHz
Insertion loss	< 0.40 dB, dc to 4 GHz
Isolation between ports	> 100 dB, dc to 4 GHz
SWR through line	< 1.30, dc to 4 GHz
Into internal 75 Ω load	< 1.30 to 4 GHz
Solenoid voltage	24 VDC
Insertion loss repeatability dc to 4 GHz	< 0.03 dB (typical up to 1,000,000 cycles)
Connectors <sup>1</sup>	Mini SMB (m) 75 Ω

- (m) male connectors = jack  
(f) female connectors = plug

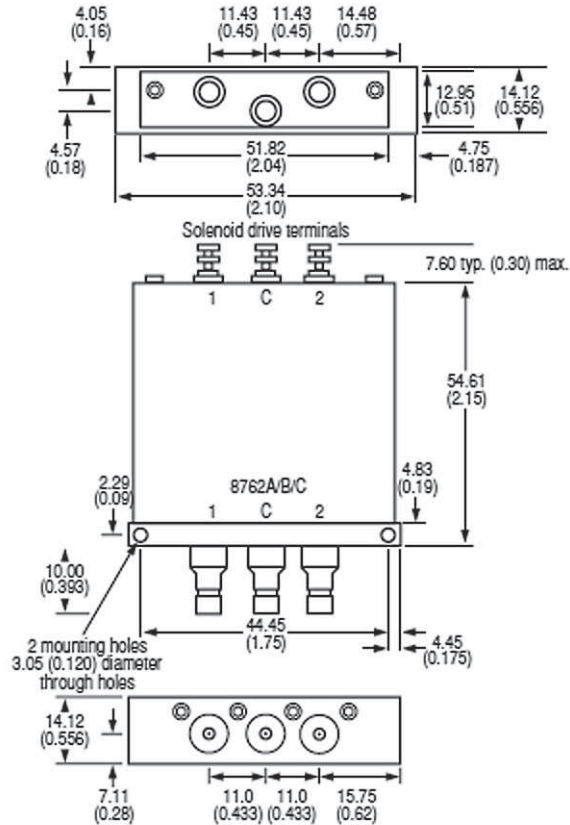

Dimensions in millimeters (inches)

Figure 4.

## General operating data

Maximum power rating	1 watt average; 100 watts peak; +7 Vdc			
Life (typical)	> 1,000,000 cycles			
Switching solenoid	Switching speed 30 mS maximum			
Solenoid electrical specifications and switching voltage options	<b>Option</b>	<b>Voltage</b>	<b>Current</b>	<b>Impedance</b>
	8762F-024	24 Vdc (20 to 30 Vdc)	120 mA @ 24 Vdc	200 $\Omega$ , 127 mH
	8762F-011	5 Vdc (4.5 to 7 Vdc)	400 mA @ 5 Vdc	13 $\Omega$ , 8 mH
	8762F-015	15 Vdc (12 to 20 Vdc)	182 mA @ 15 Vdc	82 $\Omega$ , 57 mH

## Environmental

Operating temperature	-25 °C to +75 °C
Humidity	95% RH, 40 °C, 5 days
Vibration	0.05", 10 to 55 Hz
Shock	50 g's, 3 mS

## RF connectors

The 8762F uses the mini 75 ohm SMB connector introduced by E.F. Johnson in 1990. The mini 75 ohm SMB uses the same form factor as the 50 ohm version and the two will mate. It is important to note that these connectors will not mate to the larger diameter 75 ohm SMB or CONHEX connector. See table for the appropriate connectors and adapters.

### Connectors for RG-179 and RG-187 from E.F. Johnson<sup>1</sup>

Straight crimp plug	131-8403-001
Straight crimp bulkhead jack	131-8303-401
Right angle crimp plug	131-8403-101

### Adapters from E.F. Johnson<sup>1</sup>

Mini-SMB (m) to mini-SMB (m)	131-8901-801
Mini-SMB (f) to mini-SMB (f)	131-8901-811
Mini-SMB (m) to mini-SMB (f)	131-8901-821
Mini-SMB (f) to Type N (m)	134-1069-001
Mini-SMB (m) to Type N (m)	134-1069-011
Mini-SMB (f) to Type N (f)	134-1069-021
Mini-SMB (m) to Type N (f)	134-1069-031
Mini-SMB (m) to SMB (m) 50 ohm	134-1029-011

1. (m) male connectors = jack  
(f) female connectors = plug

## Accessories

The 11713A attenuator/switch driver is designed to provide manual and simple GPIB control of switches and attenuators. The 11713A can drive up to five 8765 series switches, ten self-interrupting switches, such as the 8762, 3, 4 or ten step attenuator sections. The 8762F standard solenoid voltage of 24 V is required for use with the 11713A.

For larger switching interfaces, the 87130A and 70611A are available for driving up to 248 switches or step attenuator sections. The 87130A is a full rack width switch controller/driver, while the 70611A is a 1/8 inch wide MMS module. Both of these drivers use the IEEE 488.2 Standard Commands for Programmable Instrumentation for controlling and configuring the switches.

The 70611-60008 is the cable interconnect kit for the 87130A and 70611A. In addition, the 84941A signal distribution board is available along with the 70611-60004 switch driver cable for the 87130A and 70611A (Option 8762F-001) to externally mount switches. See the 87130A, 70611/2/3A/C data sheets or configuration guide for more information.

## 8762F Options

### Solenoid voltage options

Option 8762F-011	5 Vdc
Option 8762F-015	15 Vdc
Option 8762F-024	24 Vdc

## Accessories

11713A	Attenuator/switch driver
70611A	MMS, Switch/attenuator driver
70611-60004	Driver extension cable
84941A	Signal distribution board
87130A	System II, Switch/attenuator driver



### Agilent Email Updates

[www.agilent.com/find/emailupdates](http://www.agilent.com/find/emailupdates)

Get the latest information on the products and applications you select.



[www.lxistandard.org](http://www.lxistandard.org)

LXI is the LAN-based successor to GPIB, providing faster, more efficient connectivity. Agilent is a founding member of the LXI consortium.

### Agilent Channel Partners

[www.agilent.com/find/channelpartners](http://www.agilent.com/find/channelpartners)

Get the best of both worlds: Agilent's measurement expertise and product breadth, combined with channel partner convenience.



Agilent Advantage Services is committed to your success throughout your equipment's lifetime. We share measurement and service expertise to help you create the products that change our world. To keep you competitive, we continually invest in tools and processes that speed up calibration and repair, reduce your cost of ownership, and move us ahead of your development curve.

[www.agilent.com/find/advantageservices](http://www.agilent.com/find/advantageservices)



[www.agilent.com/quality](http://www.agilent.com/quality)

[www.agilent.com](http://www.agilent.com)  
[www.agilent.com/find/mta](http://www.agilent.com/find/mta)

For more information on Agilent Technologies' products, applications or services, please contact your local Agilent office. The complete list is available at:

[www.agilent.com/find/contactus](http://www.agilent.com/find/contactus)

#### Americas

Canada	(877) 894 4414
Brazil	(11) 4197 3500
Latin America	305 269 7500
Mexico	01800 5064 800
United States	(800) 829 4444

#### Asia Pacific

Australia	1 800 629 485
China	800 810 0189
Hong Kong	800 938 693
India	1 800 112 929
Japan	0120 (421) 345
Korea	080 769 0800
Malaysia	1 800 888 848
Singapore	1 800 375 8100
Taiwan	0800 047 866
Thailand	1 800 226 008

#### Europe & Middle East

Austria	43 (0) 1 360 277 1571
Belgium	32 (0) 2 404 93 40
Denmark	45 70 13 15 15
Finland	358 (0) 10 855 2100
France	0825 010 700*
	*0.125 €/minute
Germany	49 (0) 7031 464 6333
Ireland	1890 924 204
Israel	972-3-9288-504/544
Italy	39 02 92 60 8484
Netherlands	31 (0) 20 547 2111
Spain	34 (91) 631 3300
Sweden	0200-88 22 55
Switzerland	0800 80 53 53
United Kingdom	44 (0) 118 9276201

Other European Countries:

[www.agilent.com/find/contactus](http://www.agilent.com/find/contactus)

Revised: July 8, 2010

Product specifications and descriptions in this document subject to change without notice.

© Agilent Technologies, Inc. 2002, 2010  
Printed in USA, August 20, 2010  
5964-3704E



**Agilent Technologies**