



Agilent 81595B Modular Optical Switches

Technical Specifications
November 2010



The Agilent 81595B 1x4 optical switch module is available for both single-mode and multimode fiber applications. These can be used in all Agilent 816x Lightwave mainframes and support automation while improving measurement repeatability. The multimode switch has excellent mode fidelity.

- 81595B Option 009: 1x4 switch for single-mode fiber
- 81595B Option 062: 1x4 switch for multimode fiber

Key Features

Wide wavelength range	Single mode	1270 nm to 1670 nm
	Multimode	700 nm to 1400 nm
Excellent repeatability	± 0.030 dB (maximum variation over 10,000 random cycles)	
Low insertion loss	Single mode	2.0 dB, < 1.25 dB typ.
	Multimode	2.0 dB, < 1.0 dB typ.
Connector types	Single mode	FC/APC (narrow keying)
	Multimode	FC/PC straight
Modular design, allowing up to 17 switches in one mainframe		

The 1 x 4 optical switch has four positions:



Agilent Technologies

Modular Design for Solution Platform

These modules enable manufacturers of optical and network components to automate their processes by routing optical signals when testing devices such as line cards, amplifiers, and active and passive components. Adding modular optical switches to this instrument platform allows flexible and cost effective all-in-one solutions to be developed for optical component test in automated test environments.

Switching Reduces Uncertainty from Connections and Eases

Test Automation

These modular switches can be used to avoid repeated reconnections during your measurements and are critical to automated procedures. The low IL and PDL and high repeatability assure minimum impact of the switch on measurement accuracy.

Switching can be performed from the button on the module, from the mainframe interface and via GPIB control. The compact form and high performance allow combining switches for multistage setups, like five 1x4 modules.

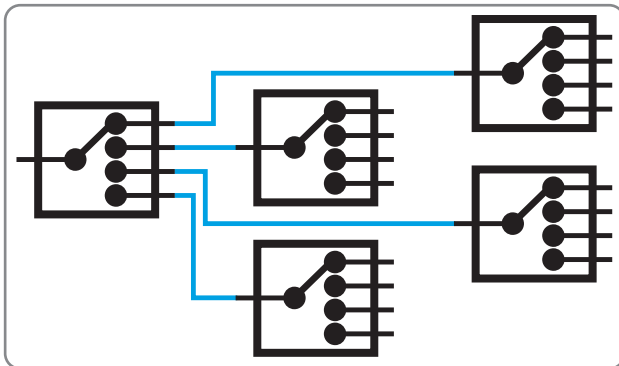

Modal Fidelity for Multimode Fiber Systems

Signals in multimode fibers are distributed over a range of mode groups that can have different loss and delay in a link. For dependable multimode transceiver testing, the instrument used to set the power level should not change this modal distribution. The Agilent multimode switches are designed with very short collimated paths between fiber, so signals propagate in practically the same distribution as through uninterrupted multimode fiber.

Agilent Technologies' Test and Measurement Support, Services, and Assistance

Agilent Technologies aims to maximize the value you receive, while minimizing your risk and problems. We strive to ensure that you get the test and measurement capabilities you paid for and obtain the support you need. Our extensive support resources and services can help you choose the right Agilent products for your applications and apply them successfully. Every instrument and system we sell has a global warranty. Support is available for at least five years beyond the production life of the product. Two concepts underlie Agilent's overall support policy: "Our Promise" and "Your Advantage."

Our Promise

Our Promise means your Agilent test and measurement equipment will meet its advertised performance and functionality. When you are choosing new equipment, we will help you with product information, including realistic performance specifications and practical recommendations from experienced test engineers. When you use Agilent equipment, we can verify that it works properly, help with product operation, and provide basic measurement assistance for the use of specified capabilities, at no extra cost upon request. Many self-help tools are available.

Your Advantage

Your Advantage means that Agilent offers a wide range of additional expert test and measurement services, which you can purchase according to your unique technical and business needs. Solve problems efficiently and gain a competitive edge by contracting with us for calibration, extra-cost upgrades, out-of-warranty repairs, and on-site education and training, as well as design, system integration, project management, and other professional engineering services. Experienced Agilent engineers and technicians worldwide can help you maximize your productivity, optimize the return on investment of your Agilent instruments and systems, and obtain dependable measurement accuracy for the life of those products.

Modular Optical Switch Specifications

81595B		
Switch type	1 x 4	
Fiber interface	# 009 single mode	# 062 multimode
Fiber type	9/125 μ m SMF	62.5/125 μ m MMF
Connectivity	FC/APC - R angled	FC/PC straight
Wavelength range	1270 nm to 1670 nm	700 nm to 1400 nm
Insertion loss	< 2.0 dB, < 1.25 dB typ. ⁴	< 2.0 dB, < 1.0 dB typ. ¹
Polarization dependent loss	typ. 0.07 dBpp	NA
Repeatability ²	\pm 0.03 dB	\pm 0.03 dB ¹
Return loss	typ. 55 dB	typ. 20 dB
Crosstalk	typ. -70 dB	typ. -70 dB
Switching time	< 10 ms	
Lifetime	> 10 million cycles	
Maximum input power	\pm 20 dBm	
Dimensions (H x W x D)	75 mm x 32 mm x 335 mm (2.9" x 1.3" X 13.2")	
Weight	0.5 kg	
Operating temperature	10 °C to 45 °C	
Storage temperature ⁵	-40 °C to 70 °C	
Humidity	Non-condensing	
Warm-up time	30 min.	

1. Specification is typical with 50/125 μ m multimode fiber.

2. Worst case measurement deviation over 10,000 random switching cycles.

3. For $\lambda = 1550$ nm; for 1270 nm < λ < 1670 nm add 0.3 dB.

4. For $\lambda = 1550$ nm; for 1270 nm < λ < 1670 nm add 0.6 dB.

5. Allow minimum acclimatization of 2 hours if previously stored outside operating temperature range before turning on the module.

Ordering information:

- Modules for single mode fiber interface: #009
- Modules for multimode fiber interface: #062



Agilent Email Updates

www.agilent.com/find/emailupdates

Get the latest information on the products and applications you select.

Agilent Channel Partners

www.agilent.com/find/channelpartners

Get the best of both worlds: Agilent's measurement expertise and product breadth, combined with channel partner convenience.



Agilent Advantage Services is committed to your success throughout your equipment's lifetime. We share measurement and service expertise to help you create the products that change our world. To keep you competitive, we continually invest in tools and processes that speed up calibration and repair, reduce your cost of ownership, and move us ahead of your development curve.

www.agilent.com/find/advantageservices



www.agilent.com/quality

www.agilent.com

www.agilent.com/comms/lightwave

www.agilent.com/comms/octcondition

For more information on Agilent Technologies' products, applications or services, please contact your local Agilent office. The complete list is available at:

www.agilent.com/find/contactus

Americas

Canada	(877) 894 4414
Brazil	(11) 4197 3500
Mexico	01800 5064 800
United States	(800) 829 4444

Asia Pacific

Australia	1 800 629 485
China	800 810 0189
Hong Kong	800 938 693
India	1 800 112 929
Japan	0120 (421) 345
Korea	080 769 0800
Malaysia	1 800 888 848
Singapore	1 800 375 8100
Taiwan	0800 047 866
Other AP Countries	(65) 375 8100

Europe & Middle East

Belgium	32 (0) 2 404 93 40
Denmark	45 70 13 15 15
Finland	358 (0) 10 855 2100
France	0825 010 700*
	*0.125 €/minute
Germany	49 (0) 7031 464 6333
Ireland	1890 924 204
Israel	972-3-9288-504/544
Italy	39 02 92 60 8484
Netherlands	31 (0) 20 547 2111
Spain	34 (91) 631 3300
Sweden	0200-88 22 55
United Kingdom	44 (0) 118 9276201

For other unlisted Countries:

www.agilent.com/find/contactus

Revised: October 14, 2010

Product specifications and descriptions in this document subject to change without notice.

© Agilent Technologies, Inc. 2010
Printed in USA, November 26, 2010
5989-1287EN



Agilent Technologies