

Agilent N4876A 28 Gb/s Multiplexer 2:1

Data Sheet, Revision 1.1



Features and Benefits

- Variable data rate up to 28.4 Gb/s
- Multiplexes two generator channels
- Front-end box for J-BERT or ParBERT
- Control via J-BERT or with stand-alone user interface via USB/LAN interface
- Small size



Agilent Technologies

Applications

Accurate characterization up to 28 Gb/s

The N4876A 28 Gb/s Multiplexer allows to extend the pattern generator data rate of the J-BERT N4903B and ParBERT 81250A up to 28.4 Gb/s. Design and test engineers in the semiconductor, communications, storage and computer industry can now accurately characterize the next generation of serial interfaces operating at bit rates of up to 28.4 Gb/s. With its excellent output performance the N4876A helps to optimize design margins by minimizing the influence of the test equipment on measurement results. The multiplexer is transparent to jitter, so when using it with the J-BERT N4903B, calibrated RJ and PJ can be generated. The small size allows locating the device under test closely to the outputs of the N4876A.

Affordable path to 28 Gb/s pattern generation

The N4876A multiplexer doubles the pattern generator data rate by multiplexing two pattern generator channels. The N4876A extends the variable generator data rate of J-BERT N4903B up to 28.4 Gb/s and of ParBERT 81250A up to 27.0 Gb/s. It's an affordable path to extend the operating rate up to 28.4 Gb/s by just adding the multiplexer front-end to a 12.5/13.5/14.2 Gb/s BERT pattern generator.

Accurate eye, mask and jitter analysis

The Agilent Infiniium DCA-X wide bandwidth oscilloscope offers the most precise waveform, eye, mask and jitter analysis of optical or electrical and advanced eye analysis options.

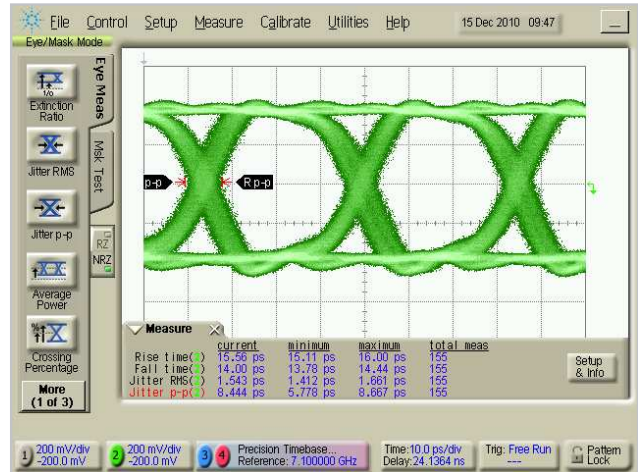

Figure 1. The N4876A multiplexer offers excellent output performance. The example shows a 28.4 Gb/s signal, using J-BERT's internal clock, PRBS15 and is captured with Agilent 86118A and 86107A precision time-based modules.

Target Applications for N4876A

- IEEE 802.3 ba 100GBASE-LR4, -ER4 interfaces operating at data rates of 25.78125 Gb/s
- OIF CEI backplanes operating between 19.9 and 28 Gb/s
- T11 16x or 32x fibre channel 14.025 and 25.8 Gb/s
- Infiniband EDR 25.78125 Gb/s
- Clean generator for transmitter test
- Stressed generator for receiver tolerance testing
- Clock/2 jitter injection
- Two differential 28 Gb/s channels when driving two MUXes from one J-BERT

J-BERT N4903B

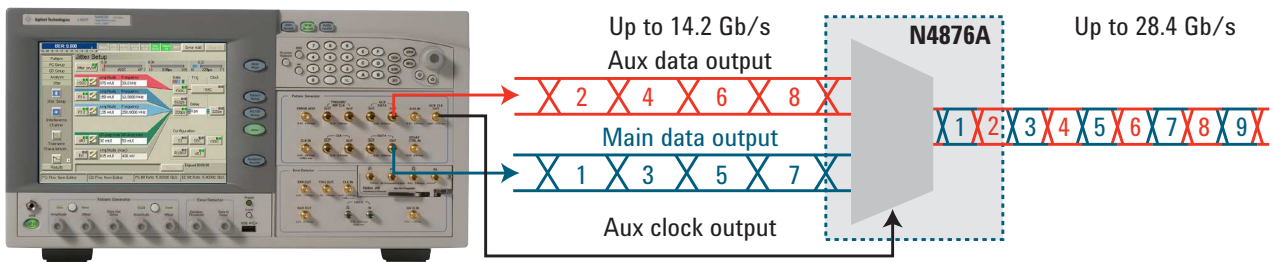

Figure 2. Two generator channels are multiplexed by the N4876A, doubling the generator data rate and interleaving the pattern bits from aux data and main data input. Example shows setup with J-BERT N4903B.

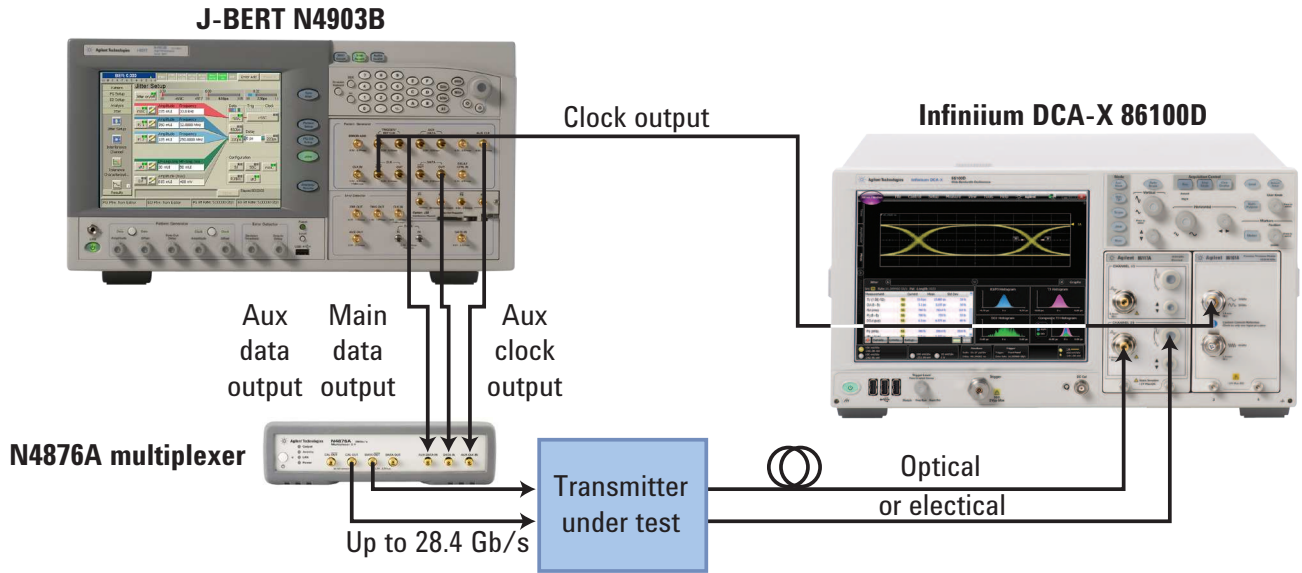

Figure 3. Transmitter test setup with N4876A, J-BERT N4903B and Infiniium DCA-X.

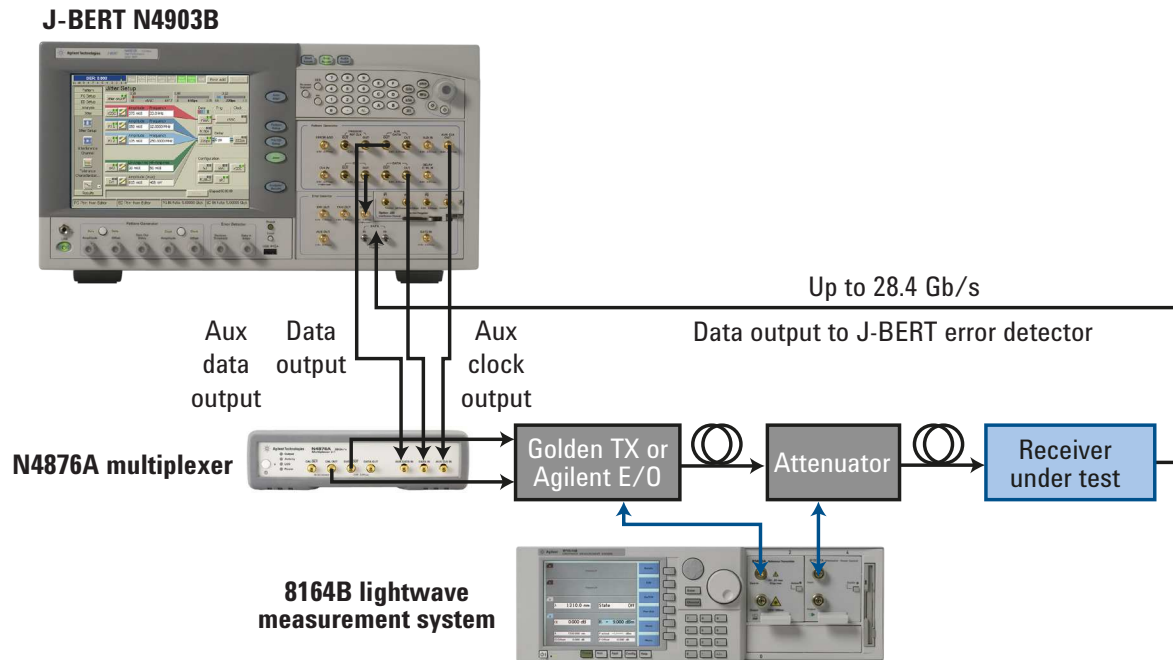

Figure 4. Receiver Tolerance Test Setup with N4876A, J-BERT N4903B using error detector clocked from main clock out and undersampling technique.

Specifications N4876A



Figure 5. Front panel view of N4876A.

Table 1. Specifications for multiplexer outputs

Output data rate	1.25 Gb/s to 27.0 Gb/s (28.4 Gb/s when using J-BERT N4903B option D14)
Output format	NRZ
Output amplitude	0.05 V _{pp} to 1.800 V _{pp} , 5 mV resolution (for single ended operation)
Output voltage window	-2.00 V to + 3.00 V
External termination voltage	- 2.00 V to +3.00 V
Output transition times	10 ps typ. (20% - 80%) 15 ps typ. (10% - 90%)
Differential skew	0 ps typ.
Intrinsic jitter	1 ps rms typical with disabled jitter sources and J-BERT N4903B internal clock and clock pattern
Jitter feed-through	Transparent for timing jitter on clock (data must be provided accordingly when used with ParBERT). S.I. and ISI shall be added after multiplexer. Notice: after multiplexing 1UI will be 2 UI
Variable Clk/2 jitter	45% to 55% or -10 ps to + 10 ps whatever is less. Notice: this means that eye 1 can be up to 10 ps longer/shorter than eye 2
Crossing point	Adjustable 20% to 80% typical
Interface	Differential or single-ended, DC coupled, 50 Ω output impedance
Connectors	2.4 mm, female

Table 2. Specifications for multiplexer inputs

Input voltage data inputs	Hi-level: 0 V nominal, max: +0.4 V Low-level: -0.8 V nominal, min.: -1.2 V, DC coupled
Input format	Data: NRZ; Clock: RZ, full-rate
Input voltage clock input	0.4 V _{pp} nominal, max: 800 mV in +/- 8V window, AC-coupled
Interface	single-ended, 50 Ω input impedance
Connectors	SMA, female

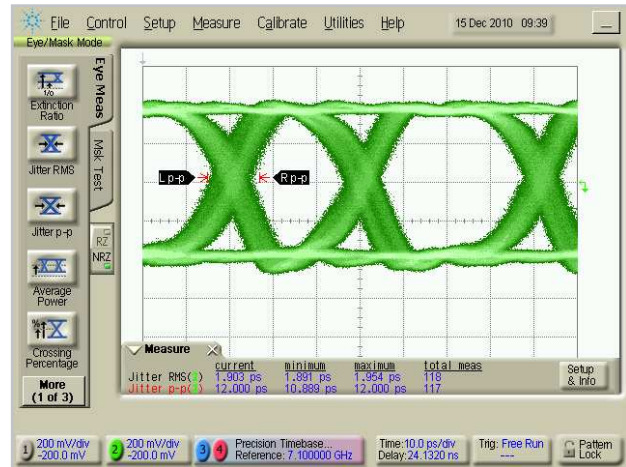

Figure 6. The N4876A allows generating bit streams where even bits have a longer (or shorter) pulse duration than odd bits. (Clock/2 jitter). Example is captured with Agilent 86118A and 86107A precision time base module.

Specifications N4876A

Table 3. General characteristics

Operating temperature	5 °C to 40 °C (-23 °F to 104 °F) Auto-adjustment required after warm-up. If operating temperature changes > 5 °C auto adjustment is needed
Storage temperature	-40 °C to +70 °C (-65 °F to 158 °F)
Operating humidity	95% relative humidity, non-condensing
Storage humidity	50% relative humidity
Power requirements	100V to 240V +/-10%, 50 Hz to 60 Hz, 80 VA
Physical dimensions (W x H x D)	Bench top with bumper: 228 x 59 x 360 mm (9.0 x 2.3 x 14.2 in) Rack mount without bumper: ½ x 19" width, 1U height: 213 x 44.5 x 360 mm (8.4 x 1.8 x 14.2 in)
Weight net	2,9 kg (6.4 lb)
Weight shipping	5.5 kg (12.1 lb)
Recommended recalibration period	1 year recommended. For calibration services see ordering information
Warranty period	1 year return to Agilent. See ordering instructions for extended warranty

Remote control interfaces:

Connectivity: USB 2.0, LAN (rear panel)

Programming language: SCPI

Via J-BERT N4903B: via USB, required SW rev. 6.7x or later

Download the latest software from:

www.agilent.com/find/n4876

Stand-alone user interface:

System requirements: Microsoft Windows®, Agilent IO library suite rev. 15.5, Microsoft .NET 2.0.

Control and Programming

The N4876A can be controlled via USB interface from J-BERT N4903B user interface or from a stand-alone user interface with programming examples. When using J-BERT with second channel option 002/U02, users can select MUX mode for the AUX DATA output to automatically generate a multiplexed pattern stream.

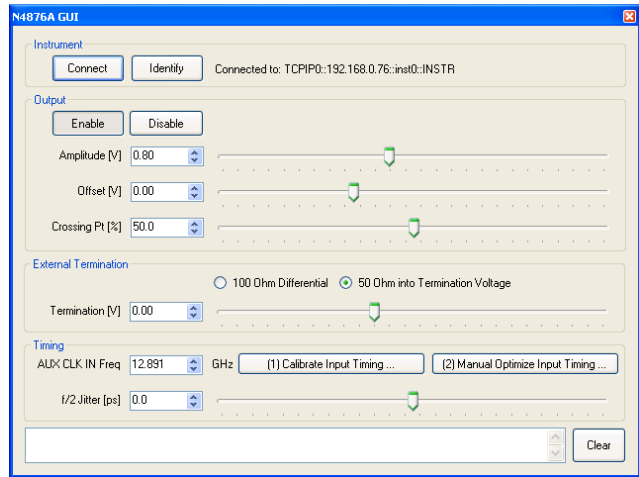

Figure 7. Controlling the N4876A multiplexer parameters from a stand-alone user interface.



Figure 8. Rear panel view of N4876A.

Specifications N4876A

Regulatory standards:

Safety: IEC61010-1:2001, EN61010-1:2001, CAN/CSA-C22 No 61010-04, UL 61010-1:2004

EMC: IEC 61326-1:2005, EN 61326-1:2006

Quality management: ISO 9001, ISO 14001

Specification assumptions:

The specifications in this document describe the instruments warranted performance. Non-warranted values are described as typical. All specifications are valid in a range from 5 °C to 40 °C ambient temperature after a warm-up time of 30 minutes and after Auto-Adjustment. If not otherwise stated, all inputs and outputs need to be terminated with 50 Ω to GND. All specifications, if not otherwise stated, are valid using the recommended cable set N4910A (2.4 mm, 24" matched pair).

Related Agilent Literature

Table 6. Related literature for N4876A

Publication title	Pub number
<i>J-BERT N4903B Data Sheet</i>	5990-3217EN
<i>81250A ParBERT Data Sheet</i>	5968-9188E
<i>Error Detection up to 28.4 Gb/s using undersampling techniques with J-BERT N4903B, Application Note</i>	5990-6239EN

Learn more

www.agilent.com/find/n4876

www.agilent.com/find/contactus

Ordering Information

Accessories included in N4876A-001: three 50 Ω terminations, three adapters 2.4 mm to 3.5 mm, USB cable, UK6 test report, USB stick with getting started guide, user software and documentation

Table 4. Ordering information for N4876A

28 Gb/s Multiplexer 2:1	N4876A-001
-------------------------	------------

Recommended accessories

2.4 mm matched cable pair	N4910A
Matched cable kit for connecting N4876A with J-BERT N4903B (2 x 2.4 mm to SMA for data/aux data, 1x SMA to SMA for clk)	N4915A-011
Short matched cable pair (2.4 mm (f) to 2.4 mm (f)) for connecting power dividers for external channel addition of N4876A or N4903B data outputs	N4915A-012
Power divider 2.4 mm, 50 GHz for external channel addition of two N4876A or N4903B outputs	11636C
Rack mount kit	E5810A-100

Warranty and calibration services

Return-to-Agilent (3 or 5 years)	R1280,R1282
On-site (not all geographies)	R1288A,R1298A
Productivity assistance	R1380-N49xx
Rack mount kit	E5810A-100

Recommended J-BERT configuration

- N4903B with Options C13, 002, and D14
- Optional: -J10 (jitter sources) and all others

Recommended ParBERT 81250A configuration

- 1x 81250A-149 13-slot ParBERT mainframe
- 1x controller (see ParBERT data sheet for options)
- 1x E4909A clock module
- 2x N4872A pattern generator module
- 1x E4875A ParBERT software



Agilent Email Updates

www.agilent.com/find/emailupdates

Get the latest information on the products and applications you select.



www.axiestandard.org

AdvancedTCA® Extensions for Instrumentation and Test (AXIe) is an open standard that extends the AdvancedTCA® for general purpose and semiconductor test. Agilent is a founding member of the AXIe consortium.



www.lxistandard.org

LAN eXtensions for Instruments puts the power of Ethernet and the Web inside your test systems. Agilent is a founding member of the LXI consortium.



<http://www.pxisa.org>

PCI eXtensions for Instrumentation (PXI) modular instrumentation delivers a rugged, PC-based high-performance measurement and automation system.

Agilent Channel Partners

www.agilent.com/find/channelpartners

Get the best of both worlds: Agilent's measurement expertise and product breadth, combined with channel partner convenience.



Agilent Advantage Services is committed to your success throughout your equipment's lifetime. We share measurement and service expertise to help you create the products that change our world. To keep you competitive, we continually invest in tools and processes that speed up calibration and repair, reduce your cost of ownership, and move us ahead of your development curve.

www.agilent.com/find/advantageservices



www.agilent.com/quality

www.agilent.com

www.agilent.com/find/n4876

For more information on Agilent Technologies' products, applications or services, please contact your local Agilent office. The complete list is available at:

www.agilent.com/find/contactus

Americas

Canada	(877) 894 4414
Brazil	(11) 4197 3500
Mexico	01800 5064 800
United States	(800) 829 4444

Asia Pacific

Australia	1 800 629 485
China	800 810 0189
Hong Kong	800 938 693
India	1 800 112 929
Japan	0120 (421) 345
Korea	080 769 0800
Malaysia	1 800 888 848
Singapore	1 800 375 8100
Taiwan	0800 047 866
Other AP Countries	(65) 375 8100

Europe & Middle East

Belgium	32 (0) 2 404 93 40
Denmark	45 70 13 15 15
Finland	358 (0) 10 855 2100
France	0825 010 700*
	*0.125 €/minute
Germany	49 (0) 7031 464 6333
Ireland	1890 924 204
Israel	972-3-9288-504/544
Italy	39 02 92 60 8484
Netherlands	31 (0) 20 547 2111
Spain	34 (91) 631 3300
Sweden	0200-88 22 55
United Kingdom	44 (0) 118 9276201

For other unlisted Countries:

www.agilent.com/find/contactus

Revised: October 14, 2010

Product specifications and descriptions in this document subject to change without notice.

© Agilent Technologies, Inc. 2011
Printed in USA, March 17, 2011
5990-5247EN



Agilent Technologies