

# Agilent M9185A

## PXI Isolated D/A Converter

8/16-Channel 16-bit,  $\pm 16$  V

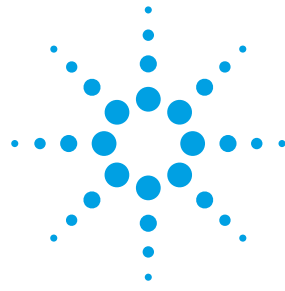

Data Sheet



**DISCOVER** the Alternatives...

... Agilent **MODULAR** Products



**Agilent Technologies**

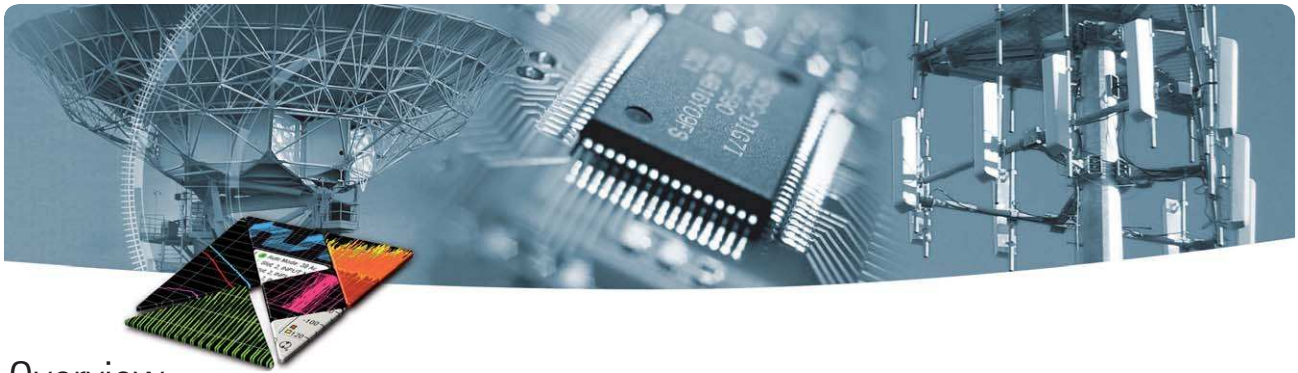

## Overview

### Introduction

The Agilent M9185A is a digital/analog converter (D/A converter) which has eight or 16 independent, isolated channels capable of supplying high voltage levels in parallel as stimulus signals to the device-under-test (DUT), making it ideal for automated test equipment (ATE) in automotive electronics.

### Product description

The M9185A is a 2- or 3-slot, PXI based, D/A converter with 16-bit resolution that is capable of providing DC voltages as stimulus to the device-under-test (DUT). The M9185A comes in eight or 16 channel option, where the eight-channel option is a 2-slot size module and the 16-channel option is a 3-slot size module. Each channel in the M9185A D/A converter is capable of supplying voltages between -16 V DC and +16 V DC at 500  $\mu$ V resolution. Each channel can also generate currents of between -20 mA and +20 mA at 630 nA resolution.

The M9185A D/A converter comes with a built-in hardware remote SENSE feature which acts as a mechanism to detect the output voltage levels and feeds the information back to the compensation circuitry of the converter. It will then use this information to auto adjust its voltage outputs to achieve the desired voltage levels. Additionally, the M9185A D/A converter is capable of providing output to a maximum level of  $\pm 16$  V per channel.

With the ability to achieve  $\pm 16$  V output voltage levels and a remote SENSE feature to guarantee that good accuracy is achieved, the M9185A is an ideal module for the automotive industry since most automotive applications require accurate voltage levels between 12 V to 14 V in order to operate the DUT.

NOTE: To ensure that an accurate voltage is present at the loads, it is recommended that you use remote sensing. However, if remote sensing is not used, do not connect loads or cables to the remote sensing terminals (H Sense and L Sense).

### Applications

- Automotive electronics test
- Functional test systems requiring isolated biasing channels
- ATE requiring remote sensing

### Features

- Eight or 16 Isolated Channels
- Output up to  $\pm 16$  V DC or  $\pm 20$  mA DC
- 16-bit resolution
- Isolation: > 80Vdc/ac peak (channel-to-chassis or channel-to-channel)
- Synchronization: Software commands or external trigger
- Remote SENSE feature for accurate output levels (4-wire)
- Interface connector compatibility with cPCI, PXI-H, PXI-1
- Output connection using stacked VHDCI receptacle
- IVI-COM, IVI-C, LabVIEW G drivers

### Customer values

- High output voltage levels up to  $\pm 16$  V for wider range of stimulus voltages
- No pull up circuit required to achieve automotive voltage requirements of 12 V to 14 V
- Remote SENSE feature for accurate output voltages



# Easy Setup ... Test ... and Maintenance

## Hardware platform

### Compliance

The M9185A D/A converter is PXI compliant, using either a cPCI, PXI-1 or PXI Hybrid slot. The product can be integrated with other test and automation modules in cPCI, PXI-1 and PXI-H chassis (hybrid slots). The PXI format offers high performance in a small, rugged package. It is an ideal deployment platform for many automated test systems. A wide array of complementary PXI products is currently available. Products include multimeters, waveform generators, local oscillators, digitizers, down converters and switch multiplexers.

### Remote SENSE mechanism

The precision of the output voltages from D/A converters cannot always be guaranteed since there is no way to instantly obtain the voltage levels at the receiving end of a DUT. Unless a DMM is utilized to measure the voltage and a manual adjustment is made, there is always an uncertainty of the output voltage levels from the D/A converters.

The M9185A's SENSE mechanism acts as a feedback feature to auto trigger the D/A converter to adjust the voltage levels to achieve better accuracy at the receiving end of a DUT. Figure 1 shows a simplified illustration of how the SENSE mechanism works. The R is actually the path resistance, or may be the lead resistance, without sense, the DMM may only sense D/A converter OUTPUT-R. For instant, the D/A converter outputs 16 V, but DMM may only sense 15.5 V. So the SENSE mechanism will increase the voltage by triggering the D/A converter to increase up to 16.5 V; therefore what the DMM now measures is 16 V.

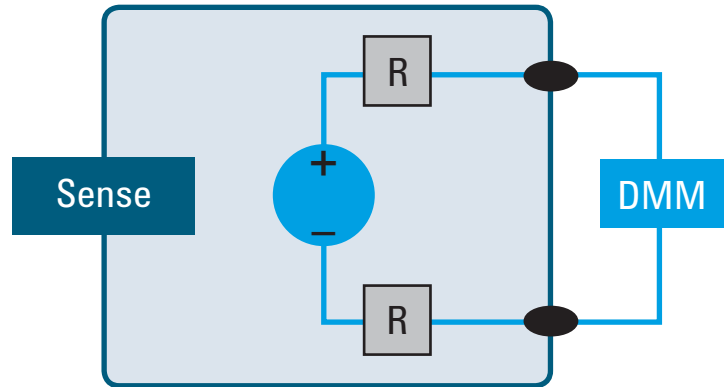

Figure 1. Basic example of the SENSE mechanism

### Using the Remote SENSE

When using the remote sensing feature, connect sense wires from the load to the High Sense and Low Sense terminals for the desired channels. When outputting current the High Sense and Low Sense terminals are not used and are opened. For protection, each channel incorporates a fuse that will open at greater than 20 mA. If an overload condition exists, the fuse will open, but no error will be generated. To reset the fuse, remove the overload and wait a few minutes for the fuse to cool.

## Software platform

### IO libraries

Agilent IO Libraries Suite offers FAST and EASY connection to instruments and the newest version extends that capability to include modular instruments.

*NEW* support for PXI — The Agilent IO Libraries Suite helps you display ALL of the modules in your system. From here you can view information about the installed software or start the modules' soft front panel. Launch the modules' soft front panel directly from Agilent Connection Expert.

### Drivers

The M9185A D/A converter is supplied with a comprehensive portfolio of module drivers, documentation, examples, and software tools to help you quickly develop test systems with your software platform of choice. The module comes with IVI-COM, IVI-C, and LabVIEW G software drivers that work in the most popular test and measurement development environments including LabVIEW and LabWindows/CVI from National Instruments, Microsoft® C/C++, C#, and VB.NET.

### Easy Software Integration

The module software support provides context sensitive help, complete documentation and code examples that allow a quick module set up and basic acquisition functionalities. These code examples can be easily modified, so that the card can be quickly integrated into a test system. Included are application code examples for LabVIEW, LabWindows/CVI, Visual Studio® C, C++, and C# and Visual Basic.

### Calibration intervals

The M9185A is factory calibrated and shipped with a calibration certificate. Calibration is recommended every year in order to verify product performance.

# Technical Specifications

## DAC specifications

Number of Channels	8 or 16 channels
Resolution	16-bit
Isolation	> 80 Vdc/ac peak (channel-to-chassis or channel to channel)
Synchronization	Software commands or external trigger.
Settling Time	500 $\mu$ s (typical)

## DC Voltage

Range	$\pm 16$ V up to 10 mA
Resolution	16-bit = 500 $\mu$ V
Accuracy	$\pm (0.05\% + 3.0$ mV)
Ripple and Noise	< 80 mVpk-pk (typical)

## DC Current

Range	$\pm 20$ mA
Resolution	16-bit = 630 nA
Accuracy	$\pm (0.09\% + 5.0$ $\mu$ A)
Ripple and Noise	< 2 $\mu$ Arms (typical)

## I/O Trigger Characteristics

### Trigger Input:

Input Level	TTL compatible (3.3 V logic, 5 V tolerant)
Slope	Rising or falling (selectable)
Pulse Width	> 100 nS
Input Impedance	> 10 k $\Omega$ typical, DC coupled

### Trigger Output:

Level	TTL compatible into 1 k $\Omega$ (3.3 V logic)
Output Impedance	50 $\Omega$ typical

# General Specifications

Environmental and physical	
Operating temperature	0 to 55° C
Storage temperature	-40 °C to 70° C
Relative humidity	80%, 0° C to 40° C (non condensing)
Altitude	10,000 ft (Operating)/15,000 ft (Non-operating)
Dimensions	8-channel: 40.30 mm x 128.40 mm x 215.00 mm 1.59 in x 5.06 in x 8.46 in 16-channel: 60.50 mm x 128.40 mm x 215.00 mm 2.38 in x 5.06 in x 8.46 in
Weight	8-Channel; 0.47 kg (1.04 lb) 16-Channel; 0.60 kg (1.32 lb)
Output connector	Stacked VHDCI receptacle
CE mark compliance	2006/95/EC; 2004/108/EC
Safety	Pollution degree 2
EMC immunity	EN/IEC 61326-1 industrial environment
EMC emissions	EN/IEC 61326-1 Class A
Warm-up time	30 minutes

Additional information	
Recommended calibration interval	1 Year

Configuration	
Hardware	
M9185A <sup>1</sup>	M9185A PXI 8/16-channel D/A converter

Related products	
Software	
Agilent IO libraries <sup>2</sup>	Agilent IO Libraries Drivers, soft front panels and programming examples in LabVIEW, LabWindows/CVI, Visual Studio C, C++ and C#, Visual Basic, and MATLAB
Accessories	
M9185A-CD1	Software and product information on CD

1. For the M9185A to work properly, at least one PXI chassis and one PXI controller type must be available.
2. Agilent IO Libraries Suite 16.0 is required. The modular product won't work with Agilent IO Libraries Suite versions earlier than version 16.0.

## Ordering

Model	Description
M9185A	M9185A PXI Digital to analog converter, 8/16-Channel, 16-bit, 16V

## Warranty and Calibration

### Advantage services: calibration and warranty

Agilent Advantage Services is committed to your success throughout your equipment's lifetime.

Warranty	Description
Standard warranty is 1 year	
R-9MB-001-3C	1 year return-to-Agilent warranty extended to 3 years
R-9MB-001-5C	1 year return-to-Agilent warranty extended to 5 years



## Definitions for specifications

**Specification (spec):** Represents warranted performance of a calibrated instrument that has been stored for a minimum of two hours within the operating temperature range of 0 to 40° C, unless otherwise stated, and after a 45-minute warm-up period. The specifications include measurement uncertainty. Data represented in this document are specifications unless otherwise noted.

**Typical (typ):** Represents characteristic performance, which 80% of the instruments manufactured will meet. This data is not warranted, does not include measurement uncertainty, and is valid only at room temperature (approximately 25° C).

**Nominal (nom):** The expected mean or average performance, or an attribute whose performance is by design, such as the 50  $\Omega$  connector. This data is not warranted and is measured at room temperature (approximately 25° C).

**Measured (meas):** An attribute measured during the design phase for purposes of communicating expected performance, such as amplitude drift vs. time. This data is not warranted and is measured at room temperature (approximately 25° C).

## The Modular Tangram

The four-sided geometric symbol that appears throughout this document is called a tangram. This seven-piece puzzle originated in China a few centuries ago. The goal is to create shapes—from simple to complex—that form an identifiable silhouette. As with a tangram, the possibilities may seem infinite as you begin to create a new test system. With a set of clearly defined elements—architecture, hardware, software—Agilent can help you create the system you need, from simple to complex.



**DISCOVER** the Alternatives ...

... Agilent **MODULAR** Products



## The Modular Tangram

The four-sided geometric symbol that appears in this document is called a tangram. The goal of this seven-piece puzzle is to create identifiable shapes—from simple to complex. As with a tangram, the possibilities may seem infinite as you begin to create a new test system. With a set of clearly defined elements—hardware, software—Agilent can help you create the system you need, from simple to complex.



**DISCOVER** the Alternatives ...  
... Agilent **MODULAR** Products

**PXI** [www.pxisa.org](http://www.pxisa.org)

**AXIe** [www.axiestandard.org](http://www.axiestandard.org)

### Agilent Channel Partners

[www.agilent.com/find/channelpartners](http://www.agilent.com/find/channelpartners)



Agilent Advantage Services is committed to your success throughout your equipment's lifetime.

[www.agilent.com/find/advantageservices](http://www.agilent.com/find/advantageservices)



### Agilent Email Updates

[www.agilent.com/find/emailupdates](http://www.agilent.com/find/emailupdates)

Visual Studio, Visual C, C++, and C#, and Visual Basic are registered trademarks of Microsoft Corporation.

Microsoft is a trademark or registered trademark of Microsoft Corporation in the United States and/or other countries..

[www.agilent.com](http://www.agilent.com)

[www.agilent.com/find/modular](http://www.agilent.com/find/modular)

[www.agilent.com/find/m9185a](http://www.agilent.com/find/m9185a)

For more information on Agilent Technologies' products, applications or services, please contact your local Agilent office. The complete list is available at: [www.agilent.com/find/contactus](http://www.agilent.com/find/contactus)

#### Americas

Canada	(877) 894 4414
Brazil	(11) 4197 3500
Mexico	01800 5064 800
United States	(800) 829 4444

#### Asia Pacific

Australia	1 800 629 485
China	800 810 0189
Hong Kong	800 938 693
India	1 800 112 929
Japan	0120 (421) 345
Korea	080 769 0800
Malaysia	1 800 888 848
Singapore	1 800 375 8100
Taiwan	0800 047 866
Other AP Countries	(65) 375 8100

#### Europe & Middle East

Belgium	32 (0) 2 404 93 40
Denmark	45 70 13 15 15
Finland	358 (0) 10 855 2100
France	0825 010 700* *0.125 €/minute
Germany	49 (0) 7031 464 6333
Ireland	1890 924 204
Israel	972-3-9288-504/544
Italy	39 02 92 60 8484
Netherlands	31 (0) 20 547 2111
Spain	34 (91) 631 3300
Sweden	0200-88 22 55
United Kingdom	44 (0) 118 9276201

For other unlisted Countries: [www.agilent.com/find/contactus](http://www.agilent.com/find/contactus)

Revised: October 14, 2010

Product specifications and descriptions in this document subject to change without notice.

© Agilent Technologies, Inc. 2011

Printed in USA, March 24, 2011

5990-7724EN



**Agilent Technologies**