

Agilent
2-Port and 4-Port
PNA-X Network Analyzer

N5241A - 10 MHz to 13.5 GHz

N5242A - 10 MHz to 26.5 GHz

Data Sheet and

Technical Specifications

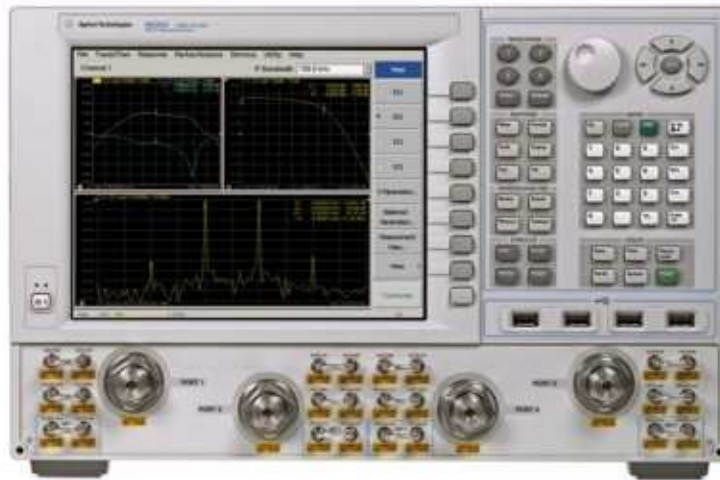
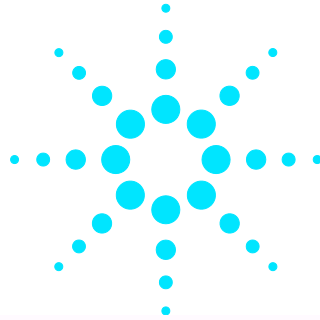

Documentation Warranty

THE MATERIAL CONTAINED IN THIS DOCUMENT IS PROVIDED "AS IS," AND IS SUBJECT TO BEING CHANGED, WITHOUT NOTICE, IN FUTURE EDITIONS. FURTHER, TO THE MAXIMUM EXTENT PERMITTED BY APPLICABLE LAW, AGILENT DISCLAIMS ALL WARRANTIES, EITHER EXPRESS OR IMPLIED WITH REGARD TO THIS MANUAL AND ANY INFORMATION CONTAINED HEREIN, INCLUDING BUT NOT LIMITED TO THE IMPLIED WARRANTIES OF MERCHANTABILITY AND FITNESS FOR A PARTICULAR PURPOSE. AGILENT SHALL NOT BE LIABLE FOR ERRORS OR FOR INCIDENTAL OR CONSEQUENTIAL DAMAGES IN CONNECTION WITH THE FURNISHING, USE, OR PERFORMANCE OF THIS DOCUMENT OR ANY INFORMATION CONTAINED HEREIN. SHOULD AGILENT AND THE USER HAVE A SEPARATE WRITTEN AGREEMENT WITH WARRANTY TERMS COVERING THE MATERIAL IN THIS DOCUMENT THAT CONFLICT WITH THESE TERMS, THE WARRANTY TERMS IN THE SEPARATE AGREEMENT WILL CONTROL.

DFARS/Restricted Rights Notice

If software is for use in the performance of a U.S. Government prime contract or subcontract, Software is delivered and licensed as "Commercial computer software" as defined in DFAR 252.227-7014 (June 1995), or as a "commercial item" as defined in FAR 2.101(a) or as "Restricted computer software" as defined in FAR 52.227-19 (June 1987) or any equivalent agency regulation or contract clause. Use, duplication or disclosure of Software is subject to Agilent Technologies' standard commercial license terms, and non-DOD Departments and Agencies of the U.S. Government will receive no greater than Restricted Rights as defined in FAR 52.227-19(c)(1-2) (June 1987). U.S. Government users will receive no greater than Limited Rights as defined in FAR 52.227-14 (June 1987) or DFAR 252.227-7015 (b)(2) (November 1995), as applicable in any technical data.

Documentation Warranty	2
DFARS/Restricted Rights Notice	2
Definitions	6
Corrected System Performance	7
Table 1a. System Dynamic Range at Test Port ¹	7
Table 1b. System Dynamic Range at Test Port ¹	8
Table 1c. System Dynamic Range at Test Port ¹	9
Table 1d. System Dynamic Range at Test Port ¹	10
Table 2a. Extended Dynamic Range at Direct Receiver Access Input ¹	11
Table 2b. Extended Dynamic Range at Direct Receiver Access Input ¹	12
Table 2c. Extended Dynamic Range at Direct Receiver Access Input ¹	13
Table 2d. Extended Dynamic Range at Direct Receiver Access Input ¹	14
N5241A and N5242A Corrected System Performance with 3.5mm Connectors	15
Table 3. 85052B Calibration Kit.....	15
Table 4. N4433A 4-Port Electronic Calibration Module.....	18
Table 5. N4691B 2- Port Electronic Calibration Module.....	21
Uncorrected System Performance	24
Table 6. Error Terms ¹	24
Test Port Output	27
Table 7. Frequency Information	27
Table 8a. Maximum Leveled Power, Option 200 or 400	27
Table 8b. Maximum Leveled Power, Option 219 or 419	32
Table 8c. Maximum Leveled Power, Option 224	33
Table 8d. Maximum Leveled Power, Option 224.....	34
Table 8e. Maximum Leveled Power, Option 423	35
Table 8f. Maximum Leveled Power, Option 224 or 423	36
Table 9a. Power Level Accuracy	37
Table 9b. Power Level Linearity - All Options.....	38
Table 9c. Power Level Linearity - All Options.....	38
Table 9d. Power Level Linearity - Option 224.....	39
Table 10a. Power Sweep Range Option 200 or 400	39
Table 10b. Power Sweep Range Option 219 or 419	40
Table 10c. Power Sweep Range Option 224 or 423.....	40
Table 10d. Power Sweep Range Option 224	41
Table 11. Nominal Power (Preset Power)	41
Table 12. Power Resolution and Maximum/Minimum Settable Power	42
Table 13. Harmonics at Max Specified Power	43
Table 13. Harmonics at Max Specified Power (continued).....	44
Table 14. Non-Harmonic Spurs at nominal power	44

Table 15. Phase Noise - All Options	45
Test Port Input	45
Table 16. Test Port Noise Floor ¹ (dBm).....	45
Table 17. Direct Receiver Access Input Noise Floor ¹ (dBm).....	46
Table 18. Test Port Compression at 0.1 dB (dBm)	47
Table 19. Test Port Compression @ 8 dBm Test Port Power (dB)	47
Table 20. Trace Noise Magnitude (dB rms).....	48
Table 21. Trace Noise Phase (deg rms).....	49
Table 22. Reference Level Magnitude	49
Table 23. Reference Level Phase.....	50
Table 24. Stability Magnitude (dB/°C)	50
Table 25. Stability Phase (°/°C).....	51
Table 26. Damage Input Level.....	51
Dynamic Accuracy	52
Table 27. Dynamic Accuracy (Specification).....	52
Table 28. Test Port Input (Group Delay) ^a	60
General Information	61
Table 29. Miscellaneous Information.....	61
Table 30. Front Panel Information.....	61
Table 31. Rear Panel Information.....	63
Table 32. Analyzer Dimensions and Weight	68
Operating Environment	68
Measurement Throughput Summary	70
Table 33. Typical Cycle Time ^a (ms) for Measurement Completion	70
Table 34. Cycle Time vs. IF Bandwidth	72
Table 35. Cycle Time vs. Number of Points.....	73
Table 36. Data Transfer Time (ms).....	75
Front-Panel Jumpers	76
Table 37. Measurement Receiver Inputs	77
Table 38. Reference Receiver Input	78
Table 39. Reference Receiver Input	79
Table 40. Reference Output	81
Table 41. Reference Output	82
Table 42. Source Outputs.....	84
Table 43. Coupler Inputs.....	86
N5241A and N5242A Option 029	87
Corrected System Performance with 3.5mm Connectors	87
Table 44. 85052B Calibration Kit.....	87
Table 45. N4433A 4-Port Electronic Calibration Module	91

Table 46. N4691B 2- Port Electronic Calibration Module.....	95
Uncorrected System Performance, N5241A and N5242A Option 029.....	99
Noise Error Terms: N5241A and N5242A Option 029	99
Table 47. Noise State Directivity, Port 1 and Port 2 ¹ (dB).....	99
Table 48. Noise State Load Match, Port 1 ¹ (dB).....	99
Table 49. Noise State Load Match, Port 2 ¹ (dB).....	100
Table 50. Noise State Reflection Tracking (S_{11} and S_{22}), Min/Max (dB)	100
Table 51. Noise State Transmission Tracking, Min/Max (dB)	101
Table 52. Noise State Source Match, Port 1 ¹ (dB)	101
Table 53. Noise State Source Match, Port 2 ¹ (dB)	102
Test Port Input: Option 029.....	102
Table 54. Receiver Noise Figure, Port 2 (dB).....	102
Table 55. Noise Jitter ^{1,2} (dB).....	103
Table 56. Noise Receiver Linearity (dB).....	103
Table 57. Noise Receiver Input Range	104
Test Port Output: Option 029.....	105
Table 58. Max Leveled Power, Port 1 Filtered Mode	105
Table 59. Max Leveled Power, Port 1 High Power Mode	105
Table 60. Max Leveled Power, Port 1 Filtered Mode	106
Table 61. Max Leveled Power, Port 1 High Power Mode	107
Table 62. Max Leveled Power, Port 1 Source 1, Combine Mode, Filtered Mode.....	107
Table 63. Max Leveled Power, Port 1 Source 1, Combine Mode, High Power Mode ...	108
Table 64. Max Leveled Power, Port 1 Source 2, Combine Mode, Filtered Mode.....	108
Table 65. Max Leveled Power, Port 1 Source 2, Combine Mode, High Power Mode ...	109
Table 66. Max Leveled Power, Port 2.....	109
Table 67. Max Leveled Power, Port 2.....	110
Test Set Block Diagrams.....	111

This is a complete list of the technical specifications for the N5241A and N5242A network analyzer with the following options:

Option 029, adds hardware and firmware for high-accuracy noise figure measurements, utilizing source correction techniques. It requires one of the following options: 219, 224, 419, or 423. It also requires an N4691B ECal module for use as an impedance tuner, and a 346-series noise source for calibration. [See the block diagram.](#)

Option 200, 2-port standard test set (includes six front-panel access loops) and power range. [See the block diagram.](#)

Option 219, adds 2-port extended power range, source and receiver attenuators, and bias-tees (requires Option 200). [See the block diagram.](#)

Option 224, adds an internal second source, a combiner, and mechanical switches to the 2-port analyzer (requires Option 200, 219, and 080). [See the block diagram.](#)

Option 400, 4-port standard test set (includes twelve front-panel access loops), power range, and an internal second source (Option 080 recommended). [See the block diagram.](#)

Option 419, adds 4-port extended power range, source and receiver attenuators, and bias-tees (requires Option 400). [See the block diagram.](#)

Option 423, adds an internal combiner, and mechanical switches to the 4-port analyzer (requires Option 400, 419, and 080). [See the block diagram.](#)

Note

This document provides technical specifications for the 85052B calibration kit, the N4433A 4-Port ECal module, and the N4691B 2-Port ECal module. Please download our free Uncertainty Calculator from http://www.agilent.com/find/na_calculator to generate the curves for your calibration kit and PNA setup.

Definitions

All specifications and characteristics apply over a 25 °C ±5 °C range (unless otherwise stated) and 90 minutes after the instrument has been turned on.

Specification (spec.): Warranted performance. Specifications include guardbands to account for the expected statistical performance distribution, measurement uncertainties, and changes in performance due to environmental conditions.

Characteristic (char.): A performance parameter that the product is expected to meet before it leaves the factory, but that is not verified in the field and is not covered by the product warranty. A characteristic includes the same guardbands as a specification.

Typical (typ.): Expected performance of an average unit which does not include guardbands. It is not covered by the product warranty.

Nominal (nom.): A general, descriptive term that does not imply a level of performance. It is not covered by the product warranty.

Calibration: The process of measuring known standards to characterize a network analyzer's systematic (repeatable) errors.

Corrected (residual): Indicates performance after error correction (calibration). It is determined by the quality of calibration standards and how well "known" they are, plus system repeatability, stability, and noise.

Uncorrected (raw): Indicates instrument performance without error correction. The uncorrected performance affects the stability of a calibration.

Standard: When referring to the analyzer, this includes no options unless noted otherwise.

Corrected System Performance

The specifications in this section apply for measurements made with the N5241A and N5242A analyzer with the following conditions:

- 10 Hz IF bandwidth
- No averaging applied to data
- Isolation calibration with an averaging factor of 8

Table 1a. System Dynamic Range at Test Port ¹

Option 200 or 400

Description	Specification (dB) at Test Port		Typical (dB) at Test Port	
	Port 1 or 3 ²	Port 2 or 4 ²	Port 1 or 3 ²	Port 2 or 4 ²
10 MHz to 50 MHz ³	93	93	106	104
50 MHz to 100 MHz ³	103	103	116	115
100 MHz to 500 MHz ³	117	117	131	130
500 MHz to 3.2 GHz	124	127	130	135
3.2 GHz to 10 GHz	127	127	137	136
10 GHz to 13.5 GHz	127	127	134	133
13.5 GHz to 16 GHz	127	127	134	133
16 GHz to 20 GHz	127	124	133	129
20 GHz to 24 GHz	122	117	130	126
24 GHz to 26.5 GHz	112	109	124	120

1. The system dynamic range is calculated as the difference between the noise floor and the specified source maximum output power. The effective dynamic range must take measurement uncertainties and interfering signals into account.
2. Either port can be used as the source port. Any other port can be used as the receiver port.
3. May typically be degraded at particular frequencies below 500 MHz due to spurious receiver residuals.

Table 1b. System Dynamic Range at Test Port¹

Option 219 or 419

Description	Specification (dB) at Test Port		Typical (dB) at Test Port	
	Port 1 or 3 ²	Port 2 or 4 ²	Port 1 or 3 ²	Port 2 or 4 ²
10 MHz to 50 MHz ³	93	93	106	104
50 MHz to 100 MHz ³	103	103	115	114
100 MHz to 500 MHz ³	117	117	130	129
500 MHz to 3.2 GHz	124	127	130	135
3.2 GHz to 10 GHz	127	127	135	134
10 GHz to 13.5 GHz	126	125	132	131
13.5 GHz to 16 GHz	126	125	132	131
16 GHz to 20 GHz	124	122	130	127
20 GHz to 24 GHz	118	117	127	124
24 GHz to 26.5 GHz	110	106	121	117

¹ The system dynamic range is calculated as the difference between the noise floor and the specified source maximum output power. The effective dynamic range must take measurement uncertainties and interfering signals into account.

² Either port can be used as the source port. Any other port can be used as the receiver port.

³ May typically be degraded at particular frequencies below 500 MHz due to spurious receiver residuals.

Table 1c. System Dynamic Range at Test Port ¹

Option 224

Description	Specification (dB) at Test Port		Typical (dB) at Test Port	
	Source 2, Out 1	Source 2, Out 2	Source 2, Out 1	Source 2, Out 2
10 MHz to 50 MHz ²	98	93	108	105
50 MHz to 100 MHz ²	108	107	117	116
100 MHz to 500 MHz ²	122	121	132	131
500 MHz to 3.2 GHz	128	128	134	136
3.2 GHz to 10 GHz	132	132	139	139
10 GHz to 13.5 GHz	130	130	138	137
13.5 GHz to 16 GHz	130	130	138	137
16 GHz to 20 GHz	129	127	136	134
20 GHz to 24 GHz	123	122	133	132
24 GHz to 26.5 GHz	114	112	127	124

¹ The system dynamic range is calculated as the difference between the noise floor and the specified source maximum output power. The effective dynamic range must take measurement uncertainties and interfering signals into account.

² May typically be degraded at particular frequencies below 500 MHz due to spurious receiver residuals.

Table 1d. System Dynamic Range at Test Port ¹**Option 224 or 423**

Description	Specification (dB) at Test Port		Typical (dB) at Test Port			
	Port 1 or 3 ²	Port 2 or 4 ²	Port 1 or 3 ²	Port 2 or 4 ²	Source 1, Port 1 Combine Mode	Source 2, Port 1 Combine Mode
10 MHz to 50 MHz ³	93	93	106	104	104	80
50 MHz to 100 MHz ³	103	103	115	115	112	90
100 MHz to 500 MHz ³	117	117	130	130	121	99
500 MHz to 3.2 GHz	124	127	130	134	127	112
3.2 GHz to 10 GHz	127	127	136	134	132	119
10 GHz to 13.5 GHz	126	124	132	131	128	115
13.5 GHz to 16 GHz	126	124	132	131	128	115
16 GHz to 20 GHz	124	121	130	127	125	113
20 GHz to 24 GHz	117	115	127	124	121	109
24 GHz to 26.5 GHz	107	105	121	117	115	102

¹ The system dynamic range is calculated as the difference between the noise floor and the specified source maximum output power. The effective dynamic range must take measurement uncertainties and interfering signals into account.

² Either port can be used as the source port. Any other port can be used as the receiver port.

³ May typically be degraded at particular frequencies below 500 MHz due to spurious receiver residuals.

Table 2a. Extended Dynamic Range at Direct Receiver Access Input¹**Option 200 or 400**

Description	Typical (dB) at Direct Receiver Access Input	
	Port 1 or 3 ²	Port 2 or 4 ²
10 MHz to 50 MHz ³	128	128
50 MHz to 100 MHz ³	115	115
100 MHz to 500MHz ³	129	129
500 MHz to 3.2 GHz	136	139
3.2 GHz to 10 GHz	139	139
10 GHz to 13.5 GHz	139	139
13.5 GHz to 16 GHz	139	139
16 GHz to 20 GHz	139	136
20 GHz to 24 GHz	134	129
24 GHz to 26.5 GHz	124	121

¹ The direct receiver access input extended dynamic range is calculated as the difference between the direct receiver access input noise floor and the source maximum output power. The effective dynamic range must take measurement uncertainties and interfering signals into account. This set-up should only be used when the receiver input will never exceed its maximum receiver input. When the analyzer is in segment sweep mode, it can have predefined frequency segments which will output a higher power level when the extended dynamic range is required (i.e. devices with high insertion loss), and reduced power when the maximum receiver input level will occur (i.e. devices with low insertion loss). The extended range is only available in one-path transmission measurements.

² Either port can be used as the source port. Any other port can be used as the receiver port.

³ May typically be degraded at particular frequencies below 500 MHz due to spurious receiver residuals.

Table 2b. Extended Dynamic Range at Direct Receiver Access Input**Option 219 or 419**

Description	Typical (dB) at Direct Receiver Access Input	
	Port 1 or 3 ²	Port 2 or 4 ²
10 MHz to 50 MHz ³	128	128
50 MHz to 100 MHz ³	115	115
100 MHz to 500MHz ³	129	129
500 MHz to 3.2 GHz	136	139
3.2 GHz to 10 GHz	139	139
10 GHz to 13.5 GHz	138	137
13.5 GHz to 16 GHz	138	137
16 GHz to 20 GHz	136	134
20 GHz to 24 GHz	130	129
24 GHz to 26.5 GHz	122	118

¹ The direct receiver access input extended dynamic range is calculated as the difference between the direct receiver access input noise floor and the source maximum output power. The effective dynamic range must take measurement uncertainties and interfering signals into account. This set-up should only be used when the receiver input will never exceed its maximum receiver input. When the analyzer is in segment sweep mode, it can have predefined frequency segments which will output a higher power level when the extended dynamic range is required (i.e. devices with high insertion loss), and reduced power when the maximum receiver input level will occur (i.e. devices with low insertion loss). The extended range is only available in one-path transmission measurements.

² Either port can be used as the source port. Any other port can be used as the receiver port.

³ May typically be degraded at particular frequencies below 500 MHz due to spurious receiver residuals.

Table 2c. Extended Dynamic Range at Direct Receiver Access Input¹**Option 224**

Description	Typical (dB) at Direct Receiver Access Input	
	Source 2, Out 1	Source 2, Out 2
10 MHz to 50 MHz ²	133	128
50 MHz to 100 MHz ²	120	119
100 MHz to 500MHz ²	134	133
500 MHz to 3.2 GHz	140	140
3.2 GHz to 10 GHz	144	144
10 GHz to 13.5 GHz	142	142
13.5 GHz to 16 GHz	142	142
16 GHz to 20 GHz	141	139
20 GHz to 24 GHz	135	134
24 GHz to 26.5 GHz	126	124

¹ The direct receiver access input extended dynamic range is calculated as the difference between the direct receiver access input noise floor and the source maximum output power. The effective dynamic range must take measurement uncertainties and interfering signals into account. This set-up should only be used when the receiver input will never exceed its compression or damage level. When the analyzer is in segment sweep mode, it can have predefined frequency segments which will output a higher power level when the extended dynamic range is required (i.e. devices with high insertion loss), and reduced power when receiver compression or damage may occur (i.e. devices with low insertion loss). The extended range is only available in one-path transmission measurements.

² May typically be degraded at particular frequencies below 500 MHz due to spurious receiver residuals.

Table 2d. Extended Dynamic Range at Direct Receiver Access Input**Option 224 or 423**

Description	Typical (dB) at Direct Receiver Access Input			
	Port 1 or 3 ²	Port 2 or 4 ²	Source 1, Port 1 Combine Mode	Source 2, Port 1 Combine Mode
10 MHz to 50 MHz ³	128	128	139	115
50 MHz to 100 MHz ³	115	115	124	102
100 MHz to 500MHz ³	129	129	133	111
500 MHz to 3.2 GHz	136	139	139	124
3.2 GHz to 10 GHz	139	139	144	131
10 GHz to 13.5 GHz	138	136	140	127
13.5 GHz to 16 GHz	138	136	140	127
16 GHz to 20 GHz	136	133	137	125
20 GHz to 24 GHz	129	127	133	121
24 GHz to 26.5 GHz	119	121	127	114

¹ The direct receiver access input extended dynamic range is calculated as the difference between the direct receiver access input noise floor and the source maximum output power. The effective dynamic range must take measurement uncertainties and interfering signals into account. This set-up should only be used when the receiver input will never exceed its compression or damage level. When the analyzer is in segment sweep mode, it can have predefined frequency segments which will output a higher power level when the extended dynamic range is required (i.e. devices with high insertion loss), and reduced power when receiver compression or damage may occur (i.e. devices with low insertion loss). The extended range is only available in one-path transmission measurements.

² Either port can be used as the source port. Any other port can be used as the receiver port.

³ May typically be degraded at particular frequencies below 500 MHz due to spurious receiver residuals.

Receiver Dynamic Range technical specifications are not provided in this document.

N5241A and N5242A Corrected System Performance with 3.5mm Connectors

All Options

Note: For any S_{ii} reflection measurement:

- $S_{jj} = 0$.

For any S_{ij} transmission measurement:

- $S_{ji} = S_{ij}$ when $S_{ij} \leq 1$
- $S_{ji} = 1/S_{ij}$ when $S_{ij} > 1$
- $S_{kk} = 0$ for all k

Table 3. 85052B Calibration Kit

N5241A and N5242A All Options

Applies to the N5241A and N5242A Option 200 or 219 or 224 or 400 or 419 or 423 analyzers, 85052B (3.5mm) calibration kit, 85131F flexible test port cable set, and a full 2-port calibration. Also applies to the following condition:

Environmental temperature $23^\circ \pm 3^\circ \text{C}$, with $< 1^\circ \text{C}$ deviation from calibration temperature

Description	Specification (dB)				
	50 MHz to 500 MHz	500 MHz to 2 GHz	2 GHz to 13.5 GHz	13.5 GHz to 20 GHz	20 to 26.5 GHz
Directivity	48	48	44	44	44
Source Match	40	40	31	31	31
Load Match	48	48	44	44	44
Reflection Tracking ¹	± 0.003 $+0.010/^\circ\text{C}$	± 0.003 $+0.010/^\circ\text{C}$	± 0.006 $+0.020/^\circ\text{C}$	± 0.006 $+0.020/^\circ\text{C}$	± 0.006 $+0.030/^\circ\text{C}$
Transmission Tracking ¹	± 0.017 $+0.010/^\circ\text{C}$	± 0.017 $+0.010/^\circ\text{C}$	± 0.104 $+0.020/^\circ\text{C}$	± 0.104 $+0.020/^\circ\text{C}$	± 0.119 $+0.030/^\circ\text{C}$

¹Temperature deviation is a characteristic value.

Transmission Uncertainty

The following charts were generated for Opt 423, although they are applicable for any option excluding Opt 029.

N5241A Opt 423 with 85052B

Magnitude

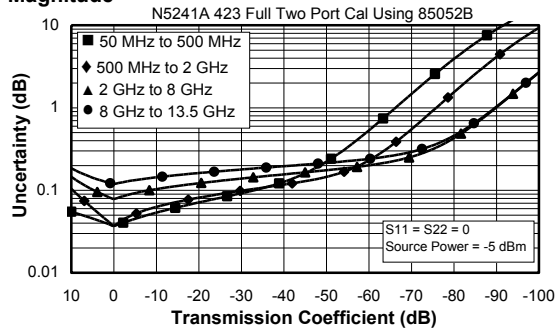

Phase

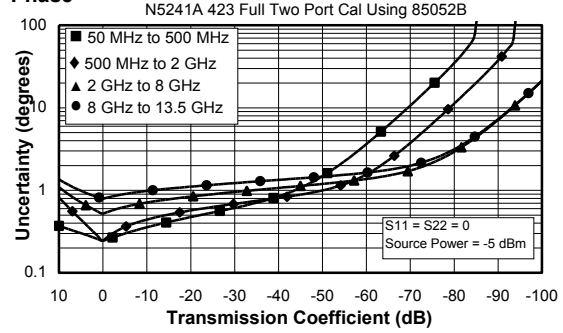

N5242A Opt 423 with 85052B

Magnitude

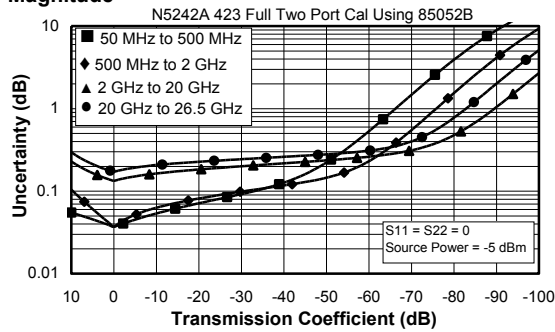

Phase

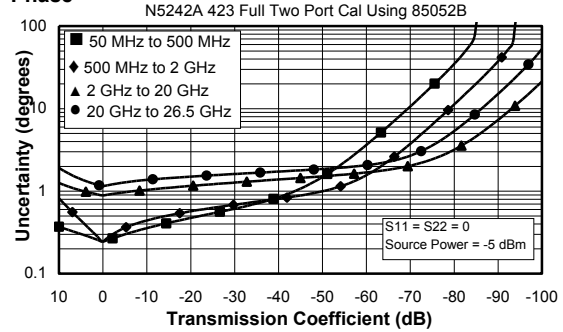

Reflection Uncertainty

The following charts were generated for Opt 423, although they are applicable for any option excluding Opt 029.

N5241A Opt 423 with 85052B

Magnitude

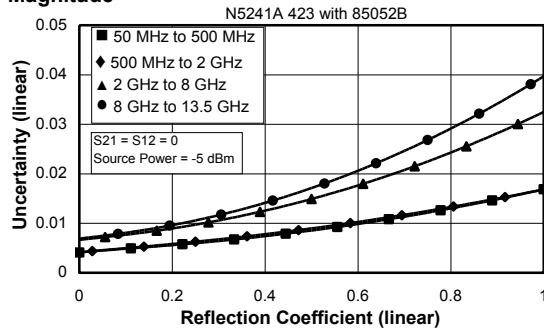

Phase

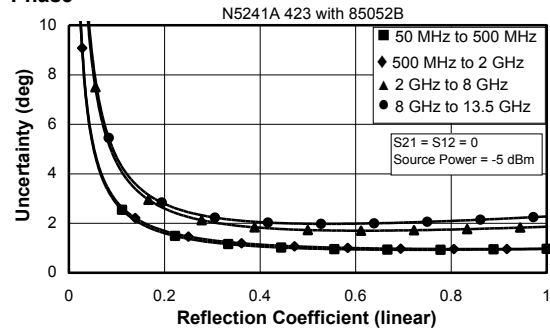

N5242A Opt 423 with 85052B

Magnitude

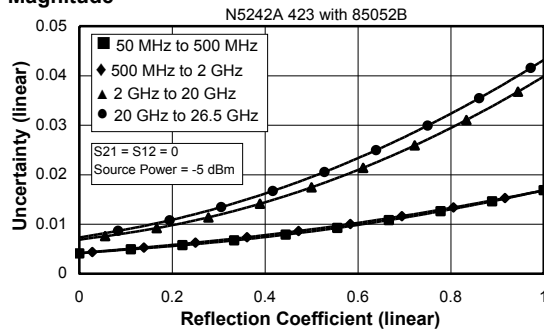

Phase

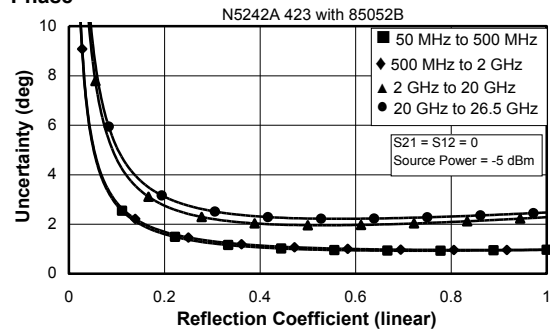

Table 4. N4433A 4-Port Electronic Calibration Module**N5241A and N5242A All Options**

Note: Uncertainty curves for the N4433A are created using a 2-port calibration. Multiport uncertainties are not supported at this time.

Applies to the N5241A and N5242A Option 200 or 219 or 224 or 400 or 419 or 423 analyzers, N4433A (3.5mm) electronic calibration module, 85131F flexible test port cable set, and a full 2-port calibration. Also applies to the following condition:

Environmental temperature $23^{\circ} \pm 3^{\circ} \text{C}$, with $< 1^{\circ} \text{C}$ deviation from calibration temperature

Description	Specification (dB)			
	50 MHz to 500 MHz	500 MHz to 2 GHz	2 GHz to 13.5 GHz	13.5 GHz to 20 GHz
Directivity	52	52	45	45
Source Match	42	42	31	31
Load Match	41	41	29	29
Reflection Tracking ¹	± 0.060 $+0.010/^{\circ}\text{C}$	± 0.060 $+0.010/^{\circ}\text{C}$	± 0.180 $+0.020/^{\circ}\text{C}$	± 0.180 $+0.020/^{\circ}\text{C}$
Transmission Tracking ¹	± 0.063 $+0.010/^{\circ}\text{C}$	± 0.063 $+0.010/^{\circ}\text{C}$	± 0.197 $+0.020/^{\circ}\text{C}$	± 0.197 $+0.020/^{\circ}\text{C}$

¹ Temperature deviation is a characteristic value.

Transmission Uncertainty

The following charts were generated for Opt 423, although they are applicable for any option excluding Opt 029.

N5241A Opt 423 with N4433A

Magnitude

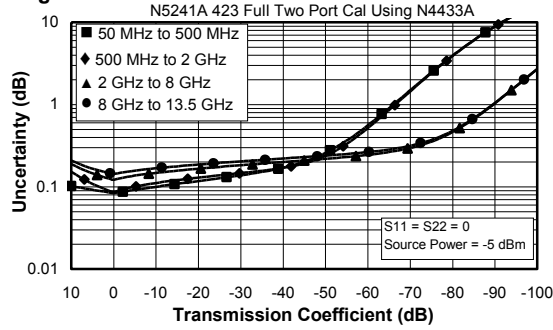

Phase

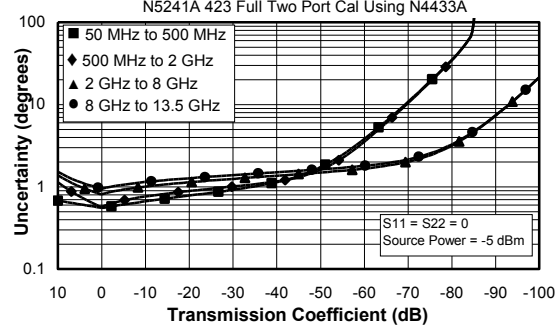

N5242A Opt 423 with N4433A

Magnitude

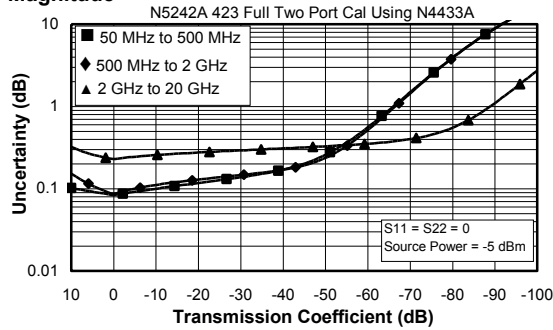

Phase

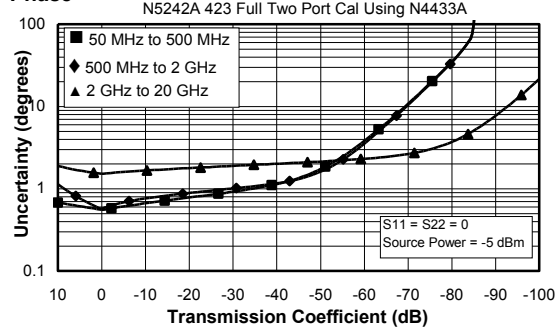

Reflection Uncertainty

The following charts were generated for Opt 423, although they are applicable for any option excluding Opt 029.

N5241A Opt 423 with N4433A

Magnitude

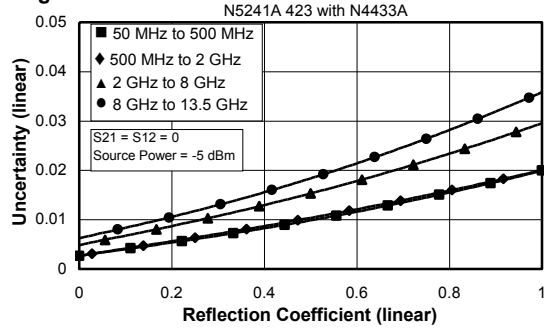

Phase

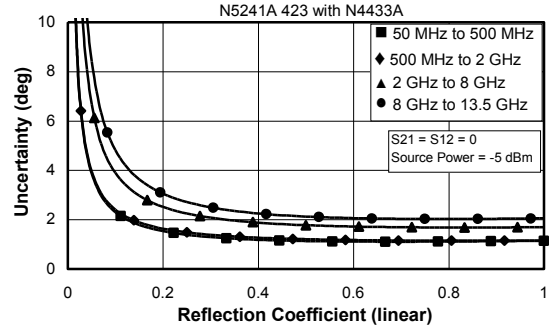

N5242A Opt 423 with N4433A

Magnitude

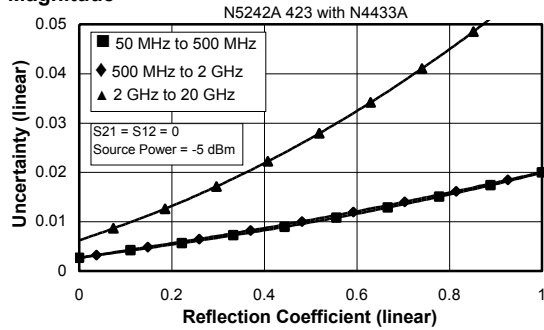

Phase

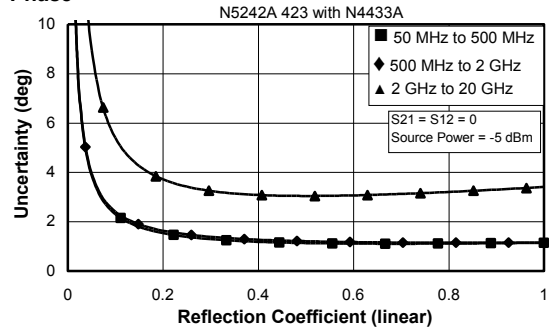

Table 5. N4691B 2- Port Electronic Calibration Module**N5241A and N5242A All Options**

Applies to the N5241A and N5242A Option 200 or 219 or 224 or 400 or 419 or 423 analyzers, N4691B (3.5mm) electronic calibration module, 85131F flexible test port cable set, and a full 2-port calibration. Also applies to the following condition:

Environmental temperature $23^{\circ} \pm 3^{\circ} \text{C}$, with $< 1^{\circ} \text{C}$ deviation from calibration temperature

Description	Specification (dB)				
	50 MHz to 500 MHz	500 MHz to 2 GHz	2 GHz to 13.5 GHz	13.5 GHz to 20 GHz	20 to 26.5 GHz
Directivity	46	56	48	48	44
Source Match	41	47	44	44	40
Load Match	40	46	42	42	38
Reflection Tracking ¹	± 0.050 $+0.010/^{\circ}\text{C}$	± 0.020 $+0.010/^{\circ}\text{C}$	± 0.040 $+0.020/^{\circ}\text{C}$	± 0.040 $+0.020/^{\circ}\text{C}$	± 0.050 $+0.030/^{\circ}\text{C}$
Transmission Tracking ¹	± 0.056 $+0.010/^{\circ}\text{C}$	± 0.022 $+0.010/^{\circ}\text{C}$	± 0.052 $+0.020/^{\circ}\text{C}$	± 0.052 $+0.020/^{\circ}\text{C}$	± 0.072 $+0.030/^{\circ}\text{C}$

¹ Temperature deviation is a characteristic value.

Transmission Uncertainty

The following charts were generated for Opt 423, although they are applicable for any option excluding Opt 029.

N5241A Opt 423 with N4691B

Magnitude

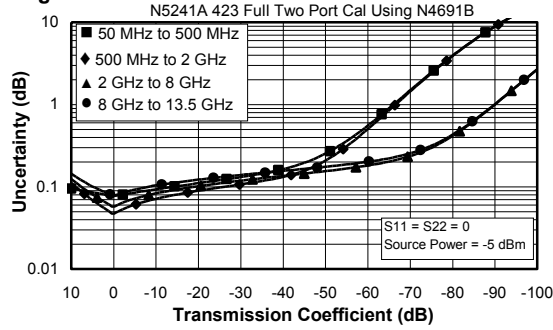

Phase

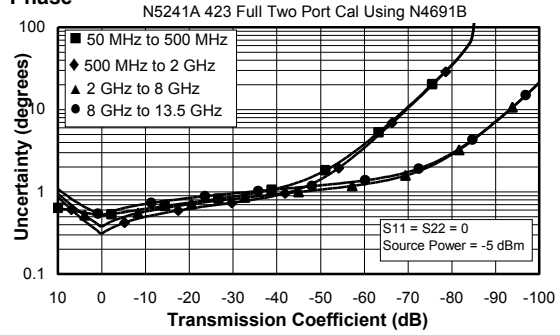

N5242A Opt 423 with N4691B

Magnitude

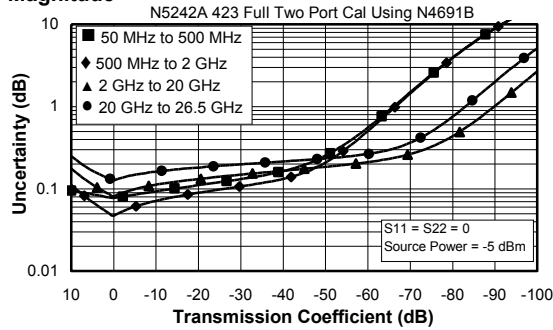

Phase

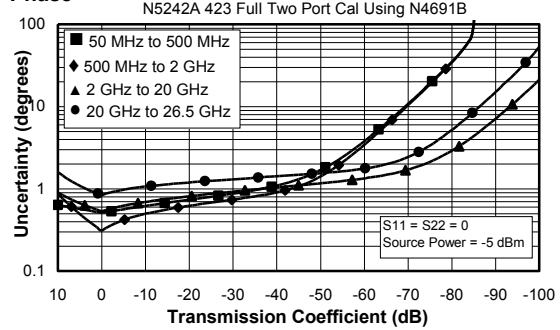

Reflection Uncertainty

The following charts were generated for Opt 423, although they are applicable for any option excluding Opt 029.

N5241A Opt 423 with N4691B

Magnitude

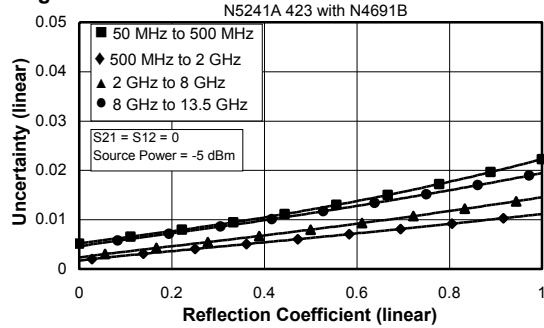

Phase

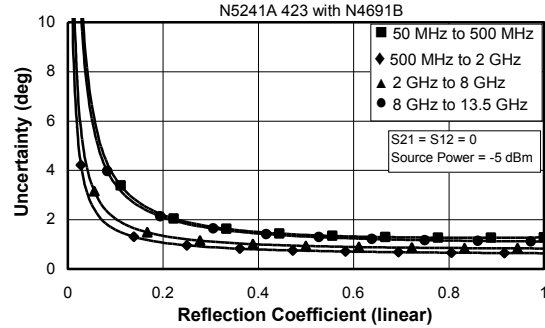

N5242A Opt 423 with N4691B

Magnitude

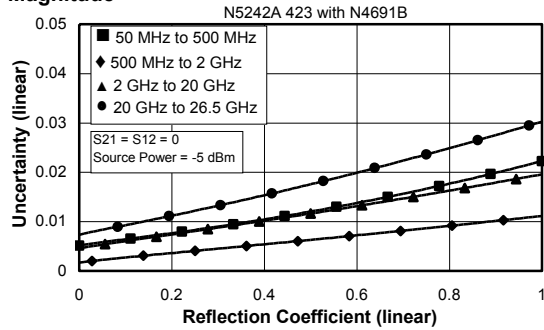

Phase

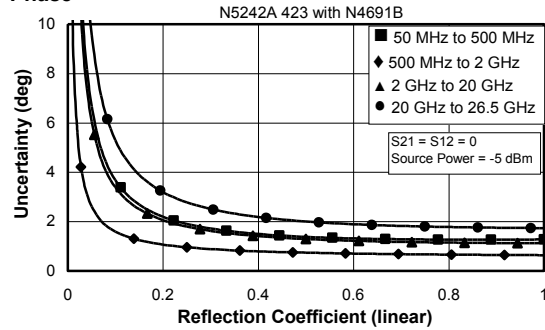

This document does not present specifications for the 85052C or 85052D Calibration Kit. Please download our free Uncertainty Calculator from http://www.agilent.com/find/na_calculator to generate the data and curves for the 85052C or the 85052D Calibration Kit.

Uncorrected System Performance

Table 6. Error Terms¹

Ports 1, 2, 3, 4. All Options. If Option 029 is included, see section [Specifications: N5241A and N5242A Option 029](#).

Description	Specification	Typical
Directivity (dB)		
10 MHz to 50 MHz	16	23
50 MHz to 500 MHz	24	28
500 MHz to 3.2 GHz	24	32
3.2 GHz to 10 GHz	23	25
10 GHz to 13.5 GHz	16	22
13.5 GHz to 16 GHz	16	22
16 GHz to 20 GHz	16	22
20 GHz to 24 GHz	16	22
24 GHz to 26.5 GHz	16	22
Source Match (dB)		
10 MHz to 50 MHz	11	14
50 MHz to 500 MHz	18	28
500 MHz to 3.2 GHz	18	22
3.2 GHz to 10 GHz	14	18
10 GHz to 13.5 GHz	12	16
13.5 GHz to 16 GHz	12	16
16 GHz to 20 GHz	10	15
20 GHz to 24 GHz	10	14
24 GHz to 26.5 GHz	8	12

Table 6. (Continued) Error Terms¹

Load Match (dB)		
10 MHz to 50 MHz	11	18
50 MHz to 500 MHz	17	25
500 MHz to 3.2 GHz	17	22
3.2 GHz to 10 GHz	13	17
10 GHz to 13.5 GHz	10	15
13.5 GHz to 16 GHz	10	15
16 GHz to 20 GHz	9	14
20 GHz to 24 GHz	9	14
24 GHz to 26.5 GHz	8	13
Transmission Tracking² (dB)		
10 MHz to 13.5 GHz	--	+/-1.5
13.5 GHz to 26.5 GHz	--	+/-1.5
Reflection Tracking (dB)		
10 MHz to 13.5 GHz	--	+/-1.5
13.5 GHz to 26.5 GHz	--	+/-1.5

Table 6. (Continued) Error Terms¹

Crosstalk³ (dB)		
10 MHz to 50 MHz	--	-84
50 MHz to 100 MHz		-90
100 MHz to 500 MHz		-110
500 MHz to 3.2 GHz		-120
3.2 GHz to 13.5 GHz		-122
13.5 GHz to 20 GHz		-122
20 GHz to 24 GHz		-117
24 GHz to 26.5 GHz		-114

¹ Specifications apply over environmental temperature of 25 °C ±5 °C, with less than 1°C variation from the calibration temperature.

² Cable loss not included.

³ Measurement conditions: normalized to a thru, measured with shorts on all ports, 10 Hz IF bandwidth, averaging factor of 8, alternate mode, source power set to the lesser of the maximum power-out or the maximum receiver power.

Test Port Output

Table 7. Frequency Information

All Options

Description	Specification (dB)	Typical (dB)
N5241A Frequency Range	10 MHz to 13.5 GHz	--
N5242A Frequency Range	10 MHz to 26.5 GHz	--
Frequency Resolution	1 Hz	--
Frequency Accuracy	+/- 1 ppm	--
Frequency Stability	--	+/-0.05 ppm, -10° to 70° C ¹ +/-0.1 ppm/yr maximum ²

¹ Assumes no variation in time.

² Assumes no variation in temperature.

Table 8a. Maximum Leveled Power, Option 200 or 400

Description	Specification (dBm)			Typical (dBm)		
	Port 1 or 3 ¹ Filtered Mode ² See Figure 2 (Opt 200) or Figure 5 (Opt 400)	Port 1 or 3 ¹ Hi Pwr Mode ² See Figure 3 (Opt 200) or Figure 6 (Opt 400)	Port 2 or 4 ¹	Port 1 or 3 ¹ Filtered Mode ² See Figure 2 (Opt 200) or Figure 5 (Opt 400)	Port 1 or 3 ¹ Hi Pwr Mode ² See Figure 3 (Opt 200) or Figure 6 (Opt 400)	Port 2 or 4 ¹
10 MHz to 50 MHz	8	13	13	10	19	17
50 MHz to 500 MHz	10	13	13	11	21	20
500 MHz to 3.2 GHz	10	10	13	12	13	18
3.2 GHz to 10 GHz	13	13	13	20	20	19
10 GHz to 13.5 GHz	13	13	13	17	17	16
13.5 GHz to 16 GHz	13	13	13	17	17	16
16 GHz to 20 GHz	13	13	10	16	16	12
20 GHz to 24 GHz	12	12	7	15	15	11
24 GHz to 26.5 GHz	5	5	2	11	11	7

¹ Either port can be used as the source port.

² In Filtered Mode, the signal path goes through filters to minimize harmonics below 3.2 GHz. In Hi Pwr Mode, the signal bypasses the filters to maximize output power.

Figure 1. Block Diagram, N5241A and N5242A Option 200

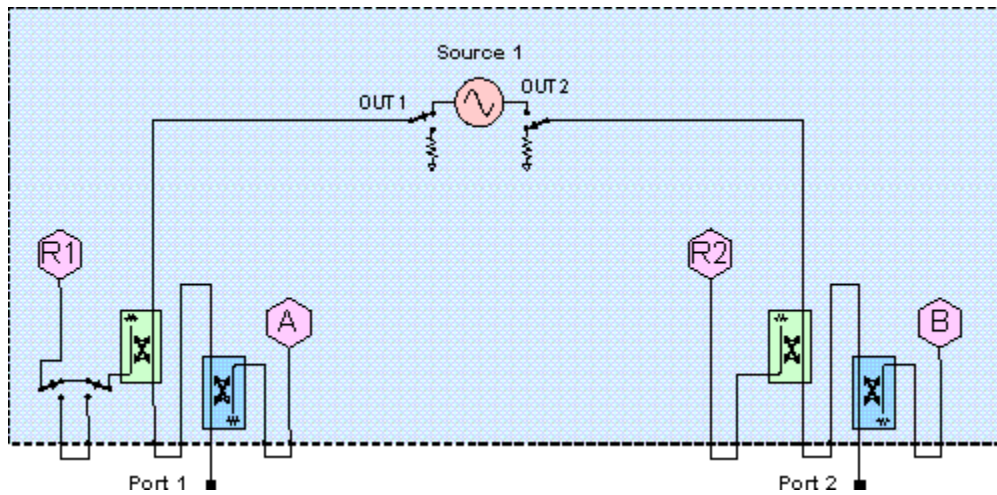

Figure 2. Path Configuration Diagram, N5241A and N5242A Option 200, Port 1 Filtered Mode

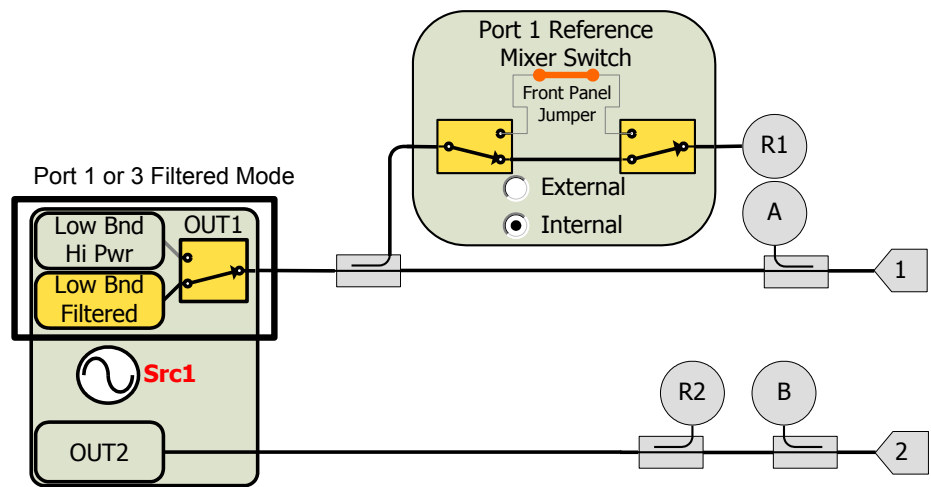

Figure 3. Path Configuration Diagram, N5241A and N5242A Option 200, Port 1 Hi Pwr Mode

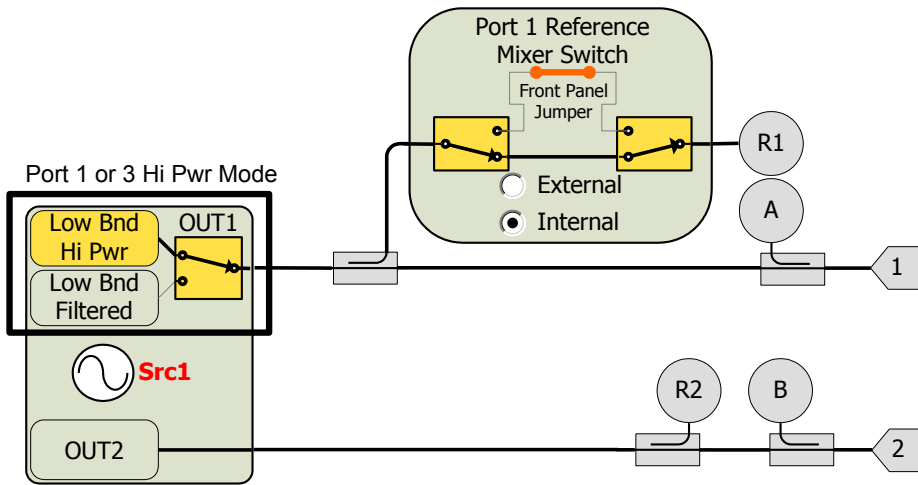

Figure 4. Block Diagram, N5241A and N5242A Option 400

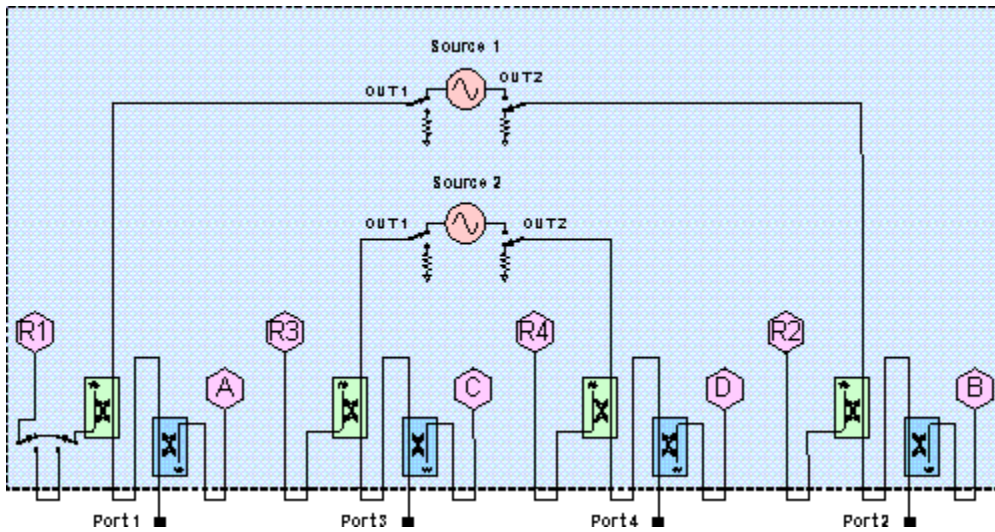

Figure 5. Path Configuration Diagram, N5241A and N5242A Option 400, Port 1 or 3 Filtered Mode

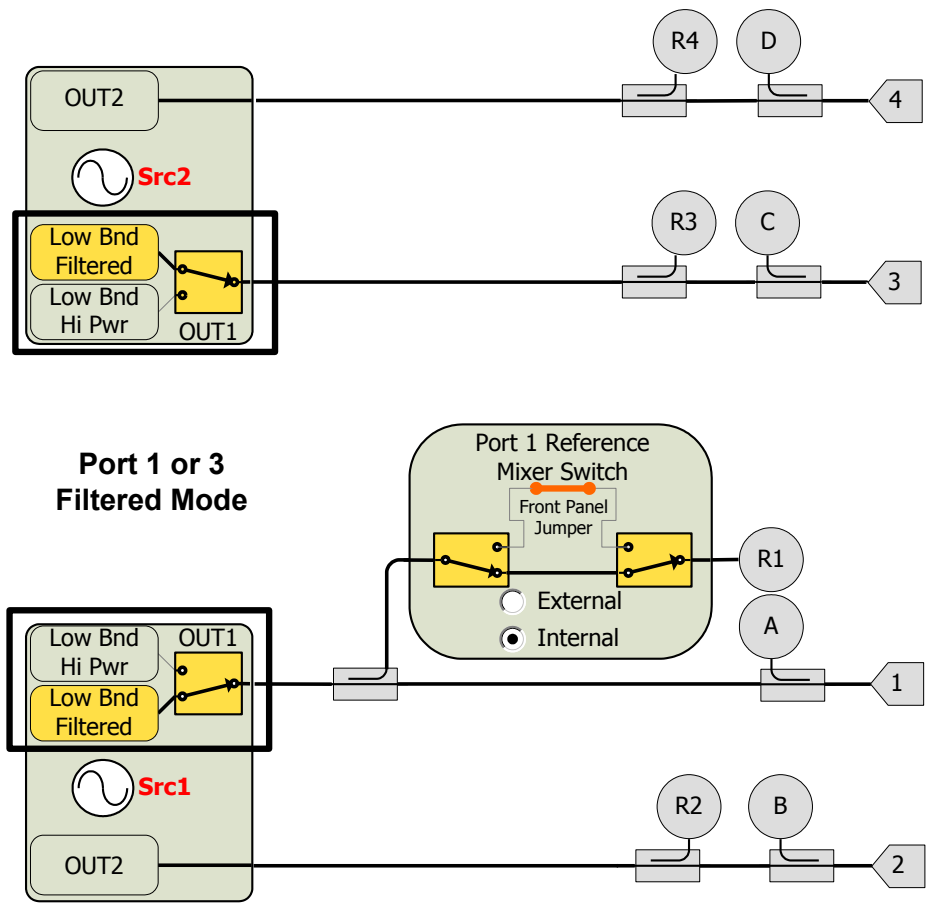

Figure 6. Path Configuration Diagram, N5241A and N5242A Option 400, Port 1 or 3 Hi Pwr Mode

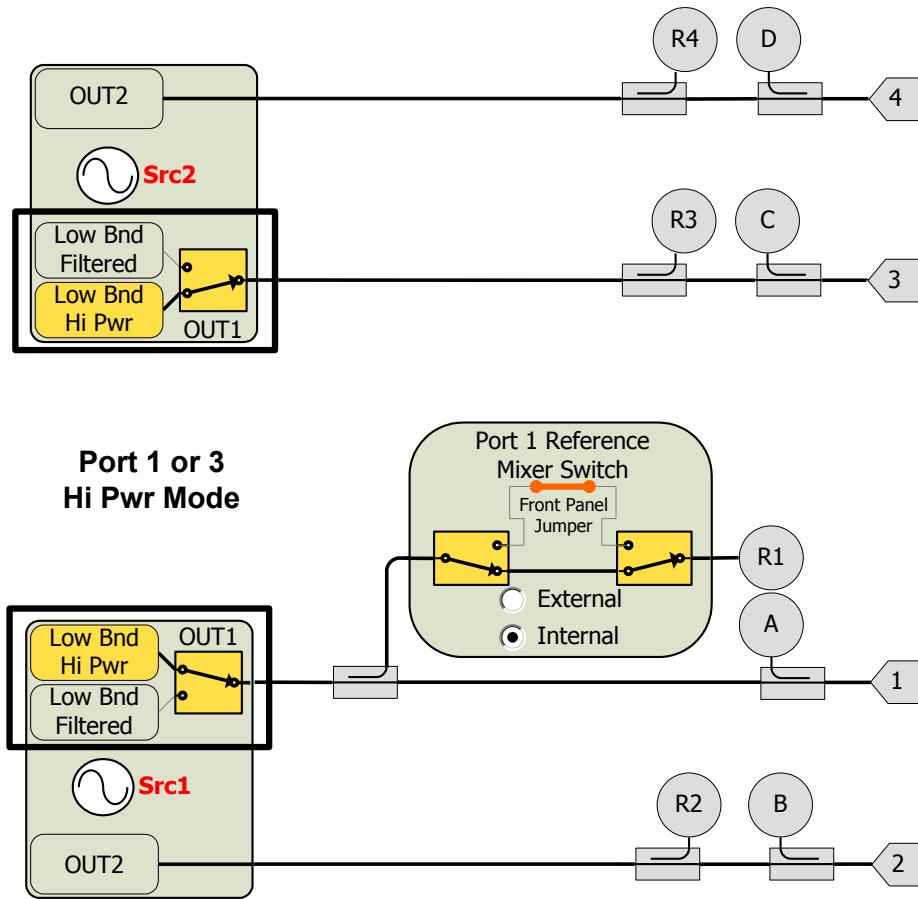

Table 8b. Maximum Leveled Power, Option 219 or 419

If Option 029 is included, see section [Specifications: Option 029](#).

Description	Specification (dBm)			Typical (dBm)		
	Port 1 or 3 ¹ Filtered Mode ²	Port 1 or 3 ¹ Hi Pwr Mode ²	Port 2 or 4 ¹	Port 1 or 3 ¹ Filtered Mode ²	Port 1 or 3 ¹ Hi Pwr Mode ²	Port 2 or 4 ¹
10 MHz to 50 MHz	8	13	13	10	19	17
50 MHz to 500 MHz	10	13	13	11	20	19
500 MHz to 3.2 GHz	10	10	13	11	13	18
3.2 GHz to 10 GHz	13	13	13	18	18	17
10 GHz to 13.5 GHz	12	12	11	15	15	14
13.5 GHz to 16 GHz	12	12	11	15	15	14
16 GHz to 20 GHz	10	10	8	13	13	10
20 GHz to 24 GHz	8	8	7	12	12	9
24 GHz to 26.5 GHz	3	3	-1	8	8	4

¹ Either port can be used as the source port.

² In Filtered Mode, the signal path goes through filters to minimize harmonics below 3.2 GHz. In Hi Pwr Mode, the signal bypasses the filters to maximize output power.

Figure 7. Block Diagram, N5241A and N5242A Option 219

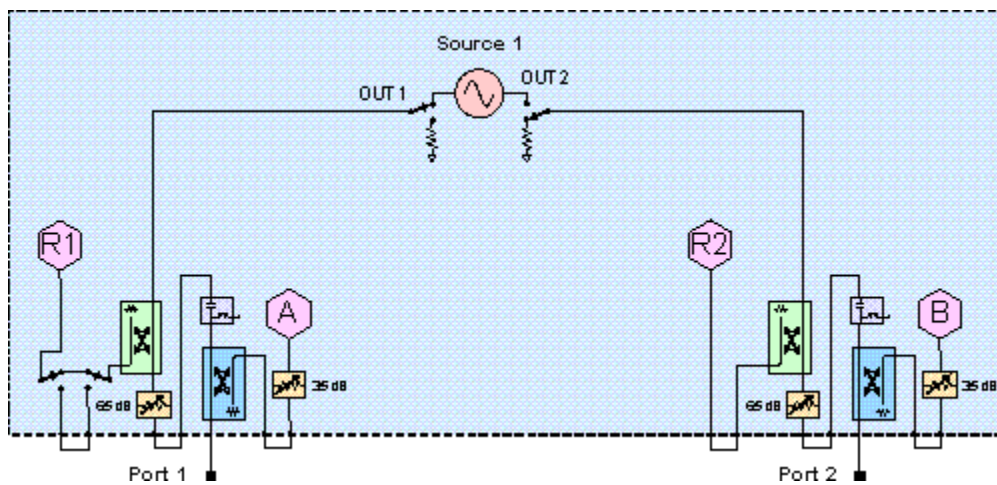

Note: The path configuration drawing for Option 219 is identical to the path configuration drawings for Option 200, which are shown in Figure 2 and Figure 3.

Figure 8. Block Diagram, N5241A and N5242A Option 419

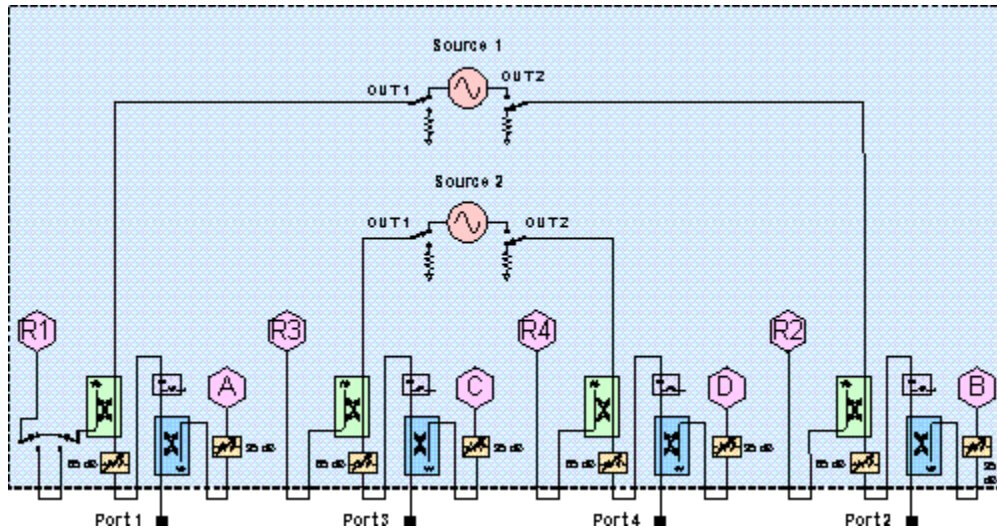

Note: The path configuration drawing for Option 419 is identical to the path configuration drawings for Option 400, which are shown in Figure 5 and Figure 6.

Table 8c. Maximum Leveled Power, Option 224

If Option 029 is included, see section [Specifications: Option 029](#).

Description	Specification (dBm)			Typical (dBm)		
	Port 1 Filtered Mode ¹	Port 1 Hi Pwr Mode ¹	Port 2	Port 1 Filtered Mode ¹	Port 1 Hi Pwr Mode ¹	Port 2
10 MHz to 50 MHz	7	13	13	9	19	17
50 MHz to 500 MHz	8	13	13	11	20	20
500 MHz to 3.2 GHz	8	10	13	11	13	17
3.2 GHz to 10 GHz	13	13	13	19	19	17
10 GHz to 13.5 GHz	12	12	10	15	15	14
13.5 GHz to 16 GHz	12	12	10	15	15	14
16 GHz to 20 GHz	10	10	7	13	13	10
20 GHz to 24 GHz	7	7	5	12	12	9
24 GHz to 26.5 GHz	0	0	-2	8	8	4

¹ In Filtered Mode, the signal path goes through filters to minimize harmonics below 3.2 GHz. In Hi Pwr Mode, the signal bypasses the filters to maximize output power.

Table 8d. Maximum Leveled Power, Option 224

Description	Specification (dBm)			Typical (dBm)		
	Source 2, Out 1 Filtered Mode ¹	Source 2, Out 1 Hi Pwr Mode ¹	Source 2, Out 2	Source 2, Out 1 Filtered Mode ¹	Source 2, Out 1 Hi Pwr Mode ¹	Source 2, Out 2
10 MHz to 50 MHz	9	18	13	12	21	18
50 MHz to 500 MHz	11	18	17	13	22	21
500 MHz to 3.2 GHz	10	14	14	13	17	19
3.2 GHz to 10 GHz	18	18	18	22	22	22
10 GHz to 13.5 GHz	16	16	16	21	21	20
13.5 GHz to 16 GHz	16	16	16	21	21	20
16 GHz to 20 GHz	15	15	13	19	19	17
20 GHz to 24 GHz	13	13	12	18	18	17
24 GHz to 26.5 GHz	7	7	5	14	14	11

¹ In Filtered Mode, the signal path goes through filters to minimize harmonics below 3.2 GHz. In Hi Pwr Mode, the signal bypasses the filters to maximize output power.

Figure 9. Block Diagram: N5241A and N5242A Option 224

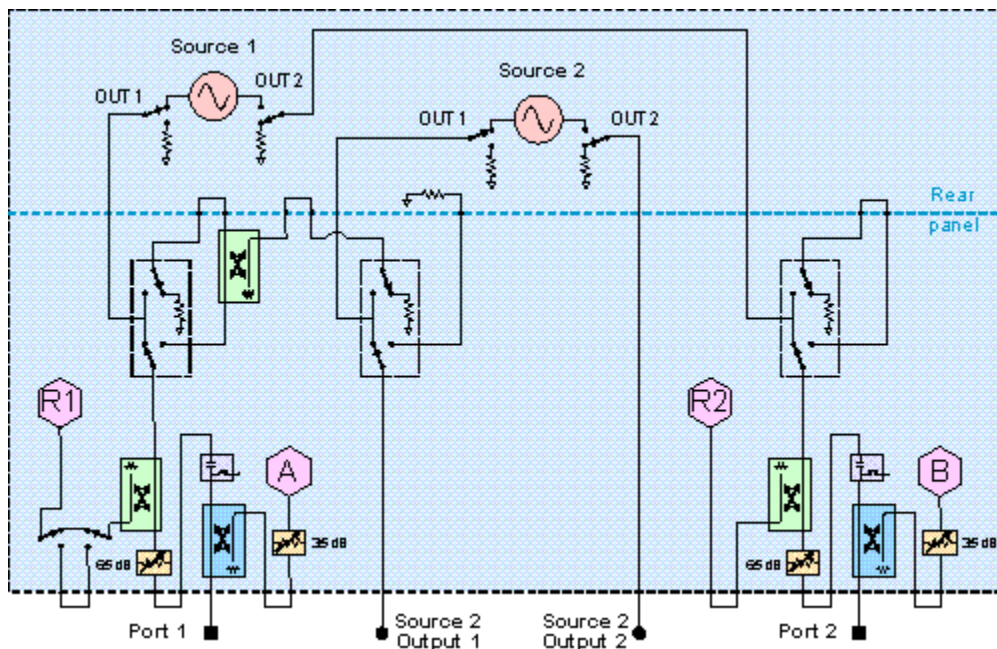

Figure 10. Path Configuration Diagram, N5241A and N5242A Option 224

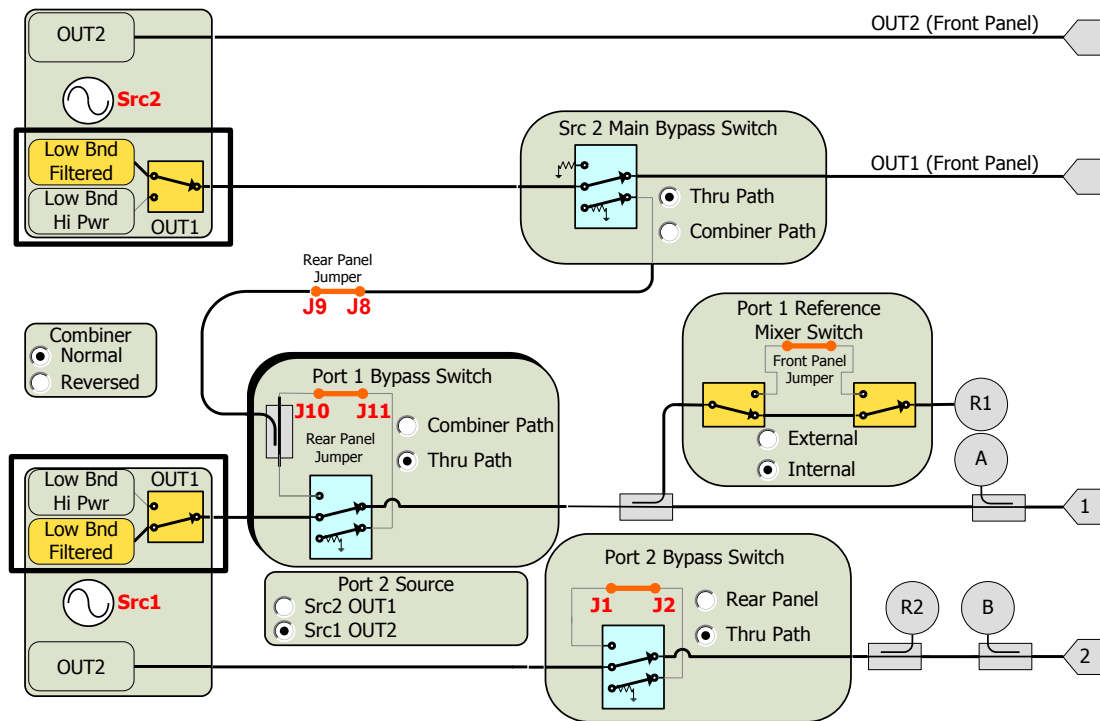

Table 8e. Maximum Levelled Power, Option 423

If Option 029 is included, see section [Specifications: Option 029](#).

Description	Specification (dBm)			Typical (dBm)		
	Port 1 or 3 Filtered Mode ¹	Port 1 or 3 Hi Pwr Mode ¹	Port 2 or 4	Port 1 or 3 Filtered Mode ¹	Port 1 or 3 Hi Pwr Mode ¹	Port 2 or 4
10 MHz to 50 MHz	7	13	13	9	19	17
50 MHz to 500 MHz	8	13	13	11	20	20
500 MHz to 3.2 GHz	8	10	13	11	13	17
3.2 GHz to 10 GHz	13	13	13	19	19	17
10 GHz to 13.5 GHz	12	12	10	15	15	14
13.5 GHz to 16 GHz	12	12	10	15	15	14
16 GHz to 20 GHz	10	10	7	13	13	10
20 GHz to 24 GHz	7	7	5	12	12	9
24 GHz to 26.5 GHz	0	0	-2	8	8	4

¹ In Filtered Mode, the signal path goes through filters to minimize harmonics below 3.2 GHz. In Hi Pwr Mode, the signal bypasses the filters to maximize output power.

Table 8f. Maximum Leveled Power, Option 224 or 423

If Option 029 is included, see section [Specifications: Option 029](#).

Description	Typical (dBm)			
	Source 1, Port 1 Combine Mode Filtered Mode ¹	Source 1, Port 1 Combine Mode Hi Pwr Mode ¹	Source 2, Port 1 Combine Mode Filtered Mode ¹	Source 2, Port 1 Combine Mode Hi Pwr Mode ¹
10 MHz to 50 MHz	7	17	-7	3
50 MHz to 500 MHz	9	17	-5	4
500 MHz to 3.2 GHz	9	10	-5	-4
3.2 GHz to 10 GHz	15	15	2	2
10 GHz to 13.5 GHz	11	11	-2	-2
13.5 GHz to 16 GHz	11	11	-2	-2
16 GHz to 20 GHz	8	8	-4	-4
20 GHz to 24 GHz	6	6	-6	-6
24 GHz to 26.5 GHz	2	2	-11	-11

¹ In Filtered Mode, the signal path goes through filters to minimize harmonics below 3.2 GHz. In Hi Pwr Mode, the signal bypasses the filters to maximize output power.

Figure 11. Block Diagram: N5241A and N5242A Option 423

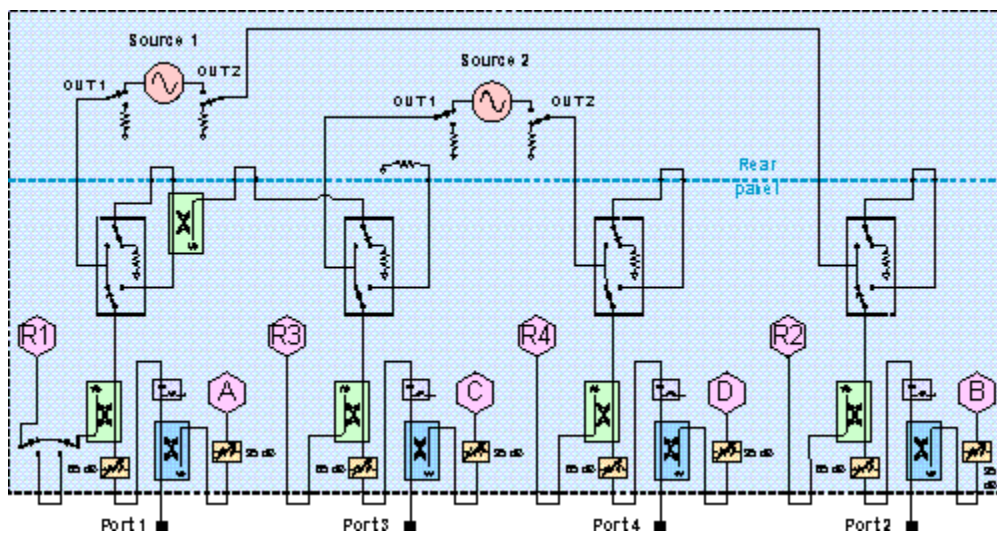

Figure 12. Path Configuration Diagram, N5241A and N5242A Option 423

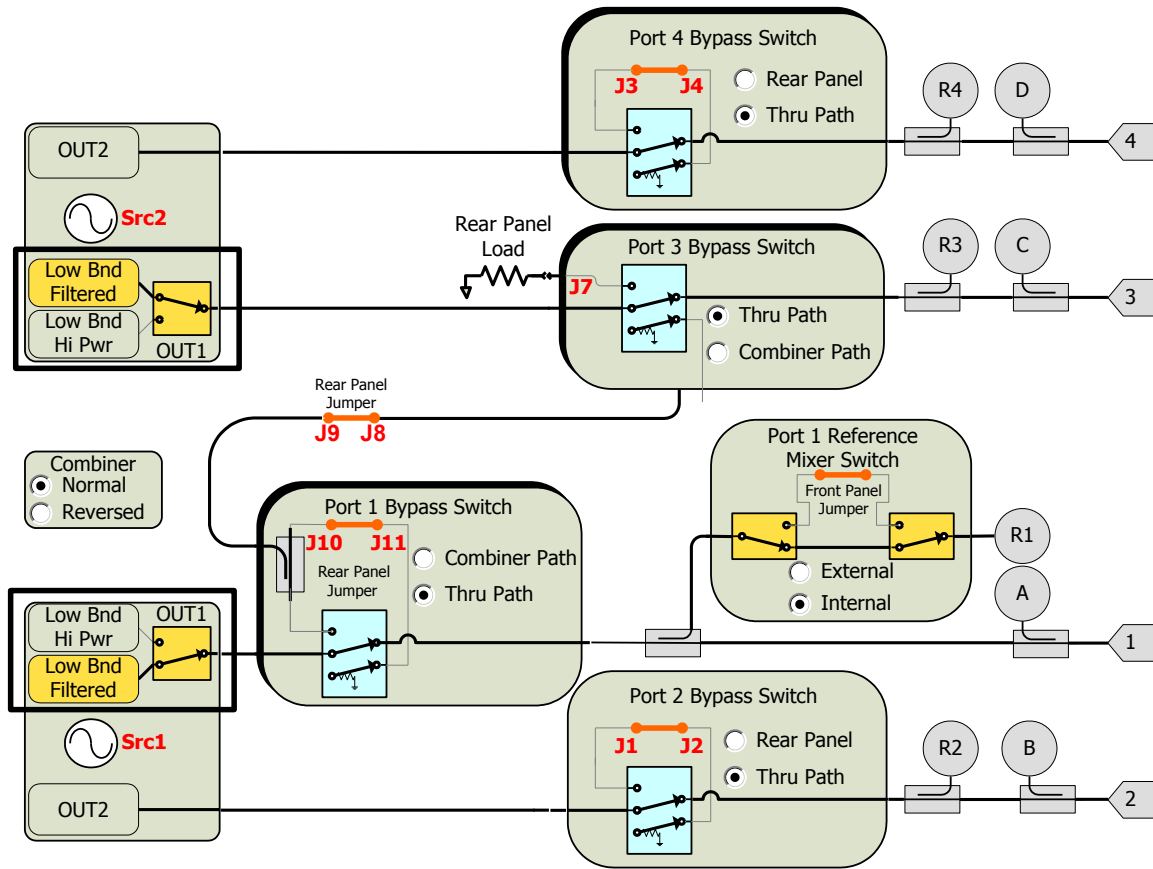

Table 9a. Power Level Accuracy

All Options

Description	Specification (dB)		Typical (dB)	
	Ports 1, 2, 3, 4 ¹	Source 2, Out 1 Source 2, Out 2	Ports 1, 2, 3, 4 ¹	Source 2, Out 1 Source 2, Out 2
10 MHz to 50 MHz	+/-1.0	+/-2.0	+/-0.40	+/-0.55
50 MHz to 500 MHz	+/-1.0	+/-2.0	+/-0.20	+/-0.25
500 MHz to 3.2 GHz	+/-1.0	+/-2.0	+/-0.25	+/-0.25
3.2 GHz to 10 GHz	+/-1.0	+/-2.0	+/-0.40	+/-0.25
10 GHz to 13.5 GHz	+/-1.2	+/-2.0	+/-0.60	+/-0.25
13.5 GHz to 18 GHz	+/-2.0	+/-2.5	+/-0.60	+/-1.00
18 GHz to 26.5 GHz	+/-2.5	+/-2.5	+/-0.80	+/-0.90

¹Any port can be used as the source port. Source in filtered mode where applicable.

Table 9b. Power Level Linearity - All Options

Description	Specification (dB)		
	Port 1 or 3 ¹ -25dBm ≤ P < -20dBm	Port 1 or 3 ¹ -20dBm ≤ P < -15dBm	Port 1 or 3 ¹ P ≥ -15dBm
10 MHz to 50 MHz	+/-2.0	+/-1.5	+/-1.0
50 MHz to 500 MHz	+/-1.5	+/-1.0	+/-1.0
500 MHz to 3.2 GHz	+/-1.0	+/-1.0	+/-1.0
3.2 GHz to 10 GHz	+/-1.0	+/-1.0	+/-1.0
10 GHz to 13.5 GHz	+/-1.0	+/-1.0	+/-1.0
13.5 GHz to 20 GHz	+/-1.0	+/-1.0	+/-1.0
20 GHz to 24 GHz	+/-1.0	+/-1.0	+/-1.0
24 GHz to 26.5 GHz	+/-1.0	+/-1.0	+/-1.0

¹ Either port can be used as the source port. Source in filtered mode.

Table 9c. Power Level Linearity - All Options

Description	Specification (dB)		
	Port 2 or 4 ¹ -25dBm ≤ P < -20dBm	Port 2 or 4 ¹ -20dBm ≤ P < -15dBm	Port 2 or 4 ¹ P ≥ -15dBm
10 MHz to 50 MHz	+/-5.0	+/-2.0	+/-1.5
50 MHz to 500 MHz	+/-4.0	+/-2.0	+/-1.5
500 MHz to 3.2 GHz	+/-2.5	+/-1.0	+/-1.0
3.2 GHz to 10 GHz	+/-2.0	+/-1.0	+/-1.0
10 GHz to 13.5 GHz	+/-1.5	+/-1.5	+/-1.5
13.5 GHz to 16 GHz	+/-1.5	+/-1.5	+/-1.5
16 GHz to 20 GHz	+/-1.0	+/-1.0	+/-1.0
20 GHz to 24 GHz	+/-1.0	+/-1.0	+/-1.0
24 GHz to 26.5 GHz	+/-1.0	+/-1.0	+/-1.0

¹ Either port can be used as the source port.

Table 9d. Power Level Linearity - Option 224

Description	Specification (dB)		
	Source 2, Out 1 ¹ P ≥ -15dBm	Source 2, Out 2 -15dBm ≤ P < -10dBm	Source 2, Out 2 P ≥ -10dBm
10 MHz to 50 MHz	+/-1.0	+/-1.5	+/-1.0
50 MHz to 500 MHz	+/-1.0	+/-1.5	+/-1.0
500 MHz to 3.2 GHz	+/-1.0	+/-1.0	+/-1.0
3.2 GHz to 10 GHz	+/-1.0	+/-1.0	+/-1.0
10 GHz to 13.5 GHz	+/-1.0	+/-1.0	+/-1.0
13.5 GHz to 16 GHz	+/-1.0	+/-1.0	+/-1.0
16 GHz to 20 GHz	+/-1.0	+/-1.0	+/-1.0
20 GHz to 24 GHz	+/-1.0	+/-1.0	+/-1.0
24 GHz to 26.5 GHz	+/-1.0	+/-1.0	+/-1.0

¹Source in filtered mode.

Table 10a. Power Sweep Range Option 200 or 400

Description	Specification (dB)		Typical (dB)	
	Port 1 or 3 ¹	Port 2 or 4 ¹	Port 1 or 3 ¹	Port 2 or 4 ¹
10 MHz to 50 MHz	33	38	46	44
50 MHz to 500 MHz	35	38	48	47
500 MHz to 3.2 GHz	35	38	40	45
3.2 GHz to 10 GHz	38	38	47	46
10 GHz to 13.5 GHz	38	38	44	43
13.5 GHz to 16 GHz	38	38	44	43
16 GHz to 20 GHz	38	35	43	39
20 GHz to 24 GHz	37	32	42	38
24 GHz to 26.5 GHz	30	27	38	34

¹ Either port can be used as the source port. Source in filtered mode where applicable.

Table 10b. Power Sweep Range Option 219 or 419

Description	Specification (dB)		Typical (dB)	
	Port 1 or 3 ¹	Port 2 or 4 ¹	Port 1 or 3 ¹	Port 2 or 4 ¹
10 MHz to 50 MHz	33	38	46	44
50 MHz to 500 MHz	35	38	47	46
500 MHz to 3.2 GHz	35	38	40	45
3.2 GHz to 10 GHz	38	38	45	44
10 GHz to 13.5 GHz	37	36	42	41
13.5 GHz to 16 GHz	37	36	42	41
16 GHz to 20 GHz	35	33	40	37
20 GHz to 24 GHz	33	32	39	36
24 GHz to 26.5 GHz	28	24	35	31

¹ Either port can be used as the source port. Source in filtered mode where applicable.

Table 10c. Power Sweep Range Option 224 or 423

Description	Specification (dB)		Typical (dB)	
	Port 1 or 3 ¹	Port 2 or 4 ¹	Port 1 or 3 ¹	Port 2 or 4 ¹
10 MHz to 50 MHz	32	38	46	44
50 MHz to 500 MHz	33	38	47	47
500 MHz to 3.2 GHz	33	38	40	44
3.2 GHz to 10 GHz	38	38	46	44
10 GHz to 13.5 GHz	37	35	42	41
13.5 GHz to 16 GHz	37	35	42	41
16 GHz to 20 GHz	35	32	40	37
20 GHz to 24 GHz	32	30	39	36
24 GHz to 26.5 GHz	25	23	35	31

¹ Either port can be used as the source port. Source in filtered mode where applicable.

Table 10d. Power Sweep Range Option 224

Description	Specification (dB)		Typical (dB)	
	Source 2 ¹ Out 1	Source 2 Out 2	Source 2 ¹ Out 1	Source 2 Out 2
10 MHz to 50 MHz	24	28	38	35
50 MHz to 500 MHz	26	32	39	38
500 MHz to 3.2 GHz	25	29	34	36
3.2 GHz to 10 GHz	33	33	39	39
10 GHz to 13.5 GHz	31	31	38	37
13.5 GHz to 16 GHz	31	31	38	37
16 GHz to 20 GHz	30	28	36	34
20 GHz to 24 GHz	28	27	35	34
24 GHz to 26.5 GHz	22	20	31	28

¹Source in filtered mode where applicable.

Table 11. Nominal Power (Preset Power)

Description	Specification (dBm)				Typical (dBm)	
	Option 200 or 400	Option 219 or 224 or 419 or 423	Option 224		Option 224 or 423	
	Ports 1, 2, 3, 4 ¹	Source 2, Out 1	Source 2, Out 2	Source 1, Port 1 Combine Mode	Source 2, Port 1 Combine Mode	
10 MHz to 13.5 GHz	0	-5	-5	-5	-5	-5
13.5 GHz to 26.5 GHz	0	-5	-5	-5	-5	-5

¹ Any port can be used as the source port. Any other port can be used as the receiver port.

Table 12. Power Resolution and Maximum/Minimum Settable Power

Description	Specification at Test Port		Typical at Test Port	
	All Options	All Options	Option 200 or 400	Option 219 or 419
	Ports 1, 2, 3, 4¹			
Power Resolution	0.01 dB	--	--	--
Maximum Settable Power	--	30 dBm	--	--
Minimum Settable Power	--	--	-30 dBm	-95 dBm

¹ Any port can be used as the source port.

Table 13. Harmonics at Max Specified Power**All Options****(See Tables 8a - 8f Maximum Leveled Power)**

Description	Typical (dBc)	
	Port 1 or 3 ^{1,2} Source 2 Out 1 ³	Port 2 or 4 ¹ Source 2 Out 2
2nd Harmonics⁴		
10 MHz to 50 MHz	-51	-13
50 MHz to 2 GHz	-51	-13
2 GHz to 3.2 GHz	-60	-21
3.2 GHz to 10 GHz	-60	-21
10 GHz to 13.5 GHz	-60	-21
13.5 GHz to 16 GHz	-60	-21
16 GHz to 20 GHz	-60	-21
20 GHz to 24 GHz	-60	-21
24 GHz to 26.5 GHz	-60	-21
3rd Harmonics⁴		
10 MHz to 50 MHz	-51	-13
50 MHz to 2 GHz	-51	-13
2 GHz to 3.2 GHz	-60	-21
3.2 GHz to 10 GHz	-60	-21
10 GHz to 13.5 GHz	-60	-21
13.5 GHz to 16 GHz	-60	-21
16 GHz to 20 GHz	-60	-21
20 GHz to 24 GHz	-60	-21
24 GHz to 26.5 GHz	-60	-21

Table 13. Harmonics at Max Specified Power (continued)

1/2 and 1/4 Sub-Harmonics⁴		
10 MHz to 50 MHz	-73	-73
50 MHz to 2 GHz	-73	-73
2 GHz to 3.2 GHz	-73	-73
3.2 GHz to 10 GHz	-66	-63
10 GHz to 13.5 GHz	-66	-63
13.5 GHz to 16 GHz	-66	-63
16 GHz to 20 GHz	-66	-63
20 GHz to 24 GHz	-61	-52
24 GHz to 26.5 GHz	-61	-52

¹ Any port can be used as the source port.

² < 3.2 GHz Filtered Mode

³ At port 1 max specified power.

⁴ Listed frequency is fundamental frequency; test at max specified power

Table 14. Non-Harmonic Spurs at nominal power

Description	Typical (dBc) at Test Port
	Ports 1, 2, 3, 4 Source 2 Out 1, Source 2 Out 2
Offset frequency = 30 kHz to 5 MHz	
10 MHz to 500 MHz	-50
500 MHz to 1 GHz	-60
1 GHz to 2 GHz	-60
2 GHz to 4 GHz	-57
4 GHz to 8 GHz	-51
8 GHz to 13.5 GHz	-45
13.5 GHz to 16 GHz	-45
16 GHz to 24 GHz	-39

24 GHz to 26.5 GHz	-33
--------------------	-----

Table 15. Phase Noise - All Options

Description	Typical (dBc/Hz)			
	Ports 1, 2, 3, 4, Source 2 Out 1, Source 2 Out 2			
	1 kHz Offset	10 kHz Offset	100 kHz Offset	1 MHz Offset
10 MHz to 500 MHz	-85	-85	-85	-120
500 MHz to 1 GHz	-105	-115	-110	-127
1 GHz to 2 GHz	-100	-110	-105	-121
2 GHz to 4 GHz	-95	-105	-100	-115
4 GHz to 8 GHz	-89	-100	-94	-110
8 GHz to 13.5 GHz	-83	-94	-88	-105
13.5 GHz to 16 GHz	-83	-94	-88	-105
16 GHz to 26.5 GHz	-78	-89	-82	-100

Test Port Input

Ports 1, 2, 3, 4. All Options. If Option 029 is included, see section [Specifications: Option 029](#).

Table 16. Test Port Noise Floor¹ (dBm)

Description	Specification	Typical
10 Hz IFBW		
10 MHz to 50 MHz ²	-80	-87
50 MHz to 100 MHz ²	-90	-95
100 MHz to 500 MHz ²	-104	-110
500 MHz to 2 GHz	-114	-117
2 GHz to 13.5 GHz	-114	-117
13.5 GHz to 20 GHz	-114	-117
20 GHz to 24 GHz	-110	-115
24 GHz to 26.5 GHz	-107	-113

¹Total average (rms) noise power calculated as the mean value of a linear magnitude trace expressed in dBm.

² May typically be degraded at particular frequencies below 500 MHz due to spurious receiver residuals.

Table 17. Direct Receiver Access Input Noise Floor¹ (dBm)

Description	Specification	Typical
10 MHz to 50 MHz ²	--	-130
50 MHz to 100 MHz ²	--	-128
100 MHz to 500 MHz ²	--	-132
500 MHz to 2 GHz	--	-133
2 GHz to 13.5 GHz	--	-129
13.5 GHz to 20 GHz	--	-129
20 GHz to 24 GHz	--	-122
24 GHz to 26.5 GHz	--	-119

¹Total average (rms) noise power calculated as the mean value of a linear magnitude trace expressed in dBm.

² May typically be degraded at particular frequencies below 500 MHz due to spurious receiver residuals.

Table 18. Test Port Compression at 0.1 dB (dBm)

Description	Specification	Typical
10 MHz to 50 MHz	--	--
50 MHz to 500 MHz	--	--
500 MHz to 3.2 GHz	--	13
3.2 GHz to 10 GHz	--	13
10 GHz to 13.5 GHz	--	13
13.5 GHz to 16 GHz	--	13
16 GHz to 20 GHz	--	12
20 GHz to 24 GHz	--	10.5
24 GHz to 26.5 GHz	--	10

Table 19. Test Port Compression @ 8 dBm Test Port Power (dB)

Description	Specification	Typical
10 MHz to 50 MHz ¹	--	--
50 MHz to 500 MHz ¹	--	--
500 MHz to 3.2 GHz	<0.17	--
3.2 GHz to 10 GHz	<0.17	--
10 GHz to 13.5 GHz	<0.17	--
13.5 GHz to 16 GHz	<0.17	--
16 GHz to 20 GHz	<0.23	--
20 GHz to 24 GHz	<0.23	--
24 GHz to 26.5 GHz	<0.29	--

¹Test port receiver compression at specified input levels below 500 MHz is negligible due to coupler roll off in this frequency range.

Table 20. Trace Noise Magnitude (dB rms)

Description	Specification	Typical
Ratioed measurement, nominal power at test port.		
1 kHz IFBW		
10 MHz to 100 MHz	0.007	0.0039
100 MHz to 13.5 GHz	0.002	0.0005
13.5 GHz to 16 GHz	0.002	0.0005
16 GHz to 22.5 GHz	0.002	0.0006
22.5 GHz to 24 GHz	0.003	0.0014
24 GHz to 26.5 GHz	0.005	0.0020
100 kHz IFBW		
10 MHz to 100 MHz	--	0.040
100 MHz to 13.5 GHz	--	0.005
13.5 GHz to 16 GHz	--	0.005
16 GHz to 22.5 GHz	--	0.005
22.5 GHz to 24 GHz	--	0.008
24 GHz to 26.5 GHz	--	0.008
600 kHz IFBW		
10 MHz to 100 MHz	--	0.140
100 MHz to 13.5 GHz	--	0.011
13.5 GHz to 16 GHz	--	0.011
16 GHz to 22.5 GHz	--	0.012
22.5 GHz to 24 GHz	--	0.020
24 GHz to 26.5 GHz	--	0.020

Table 21. Trace Noise Phase (deg rms)

Description	Specification	Typical
Ratioed measurement, nominal power at test port.		
1 kHz IFBW		
10 MHz to 100 MHz	0.051	0.0261
100 MHz to 13.5 GHz	0.015	0.0041
13.5 GHz to 16 GHz	0.042	0.0124
16 GHz to 22.5 GHz	0.042	0.0135
22.5 GHz to 26.5 GHz	0.054	0.0225
100 kHz IFBW		
10 MHz to 100 MHz	--	0.266
100 MHz to 13.5 GHz	--	0.030
13.5 GHz to 16 GHz	--	0.030
16 GHz to 22.5 GHz	--	0.033
22.5 GHz to 26.5 GHz	--	0.057
600 kHz IFBW		
10 MHz to 100 MHz	--	1.053
100 MHz to 13.5 GHz	--	0.075
13.5 GHz to 16 GHz	--	0.075
16 GHz to 22.5 GHz	--	0.082
22.5 GHz to 26.5 GHz	--	0.139

Table 22. Reference Level Magnitude

Description	Specification	Typical
Range	+/-500 dB	--
Resolution	0.001 dB	--

Table 23. Reference Level Phase

Description	Specification	Typical
Range	+/-500°	--
Resolution	0.01°	--

Table 24. Stability Magnitude (dB/°C)

Description	Specification	Typical
Stability is defined as a ratio measurement made at the test port.		
10 MHz to 50 MHz	--	0.01
50 MHz to 500 MHz	--	0.01
500 MHz to 3.2 GHz	--	0.01
3.2 GHz to 10 GHz	--	0.02
10 GHz to 13.5 GHz	--	0.02
13.5 GHz to 16 GHz	--	0.02
16 GHz to 20 GHz	--	0.03
20 GHz to 24 GHz	--	0.03
24 GHz to 26.5 GHz	--	0.04

Table 25. Stability Phase (°/°C)

Description	Specification	Typical
Stability is defined as a ratio measurement made at the test port.		
10 MHz to 50 MHz	--	0.29
50 MHz to 500 MHz	--	0.06
500 MHz to 3.2 GHz	--	0.07
3.2 GHz to 10 GHz	--	0.13
10 GHz to 13.5 GHz	--	0.13
13.5 GHz to 16 GHz	--	0.13
16 GHz to 20 GHz	--	0.40
20 GHz to 24 GHz	--	0.54
24 GHz to 26.5 GHz	--	0.56

Table 26. Damage Input Level

Description	Specification	Typical
Test Port 1 or 2 or 3 or 4	> +30 dBm RF, 40 VDC	Test Port 1 or 2 or 3 or 4
(Option 224 only) Source 2 Out 1 or Source 2 Out 2	> +30 dBm RF, 0 VDC	(Option 224 only) Source 2 Out 1 or Source 2 Out 2

Dynamic Accuracy

Table 27. Dynamic Accuracy (Specification)

Accuracy of the test port input power reading relative to the reference input power level.

Dynamic Accuracy, 0.010 GHz

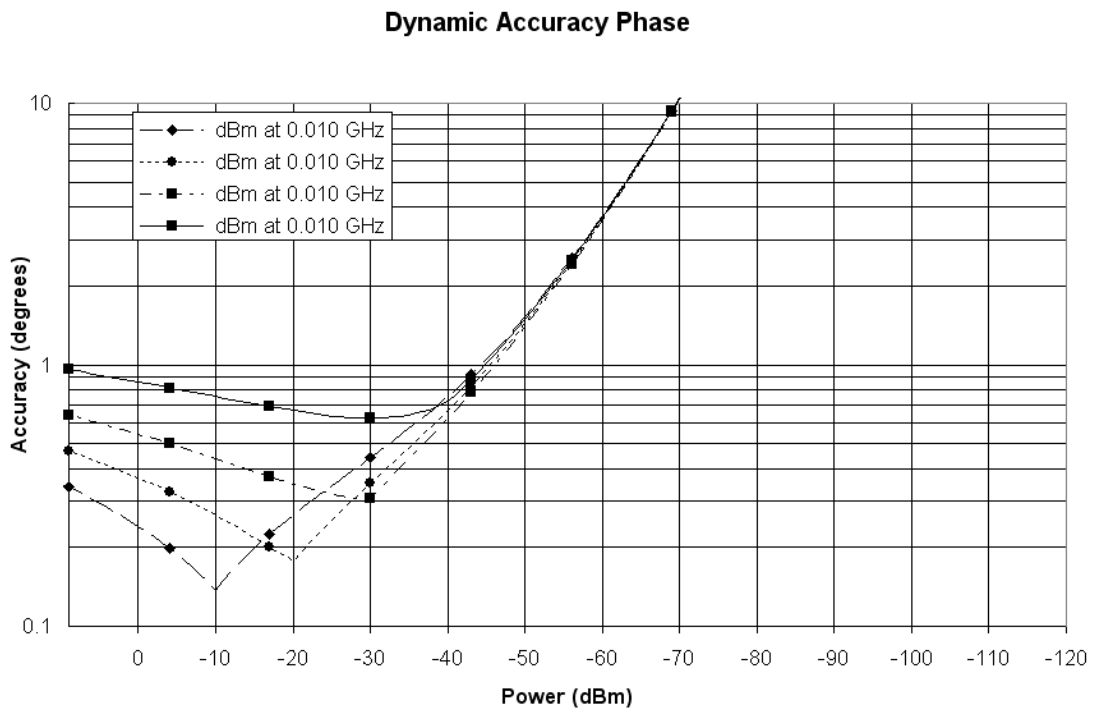
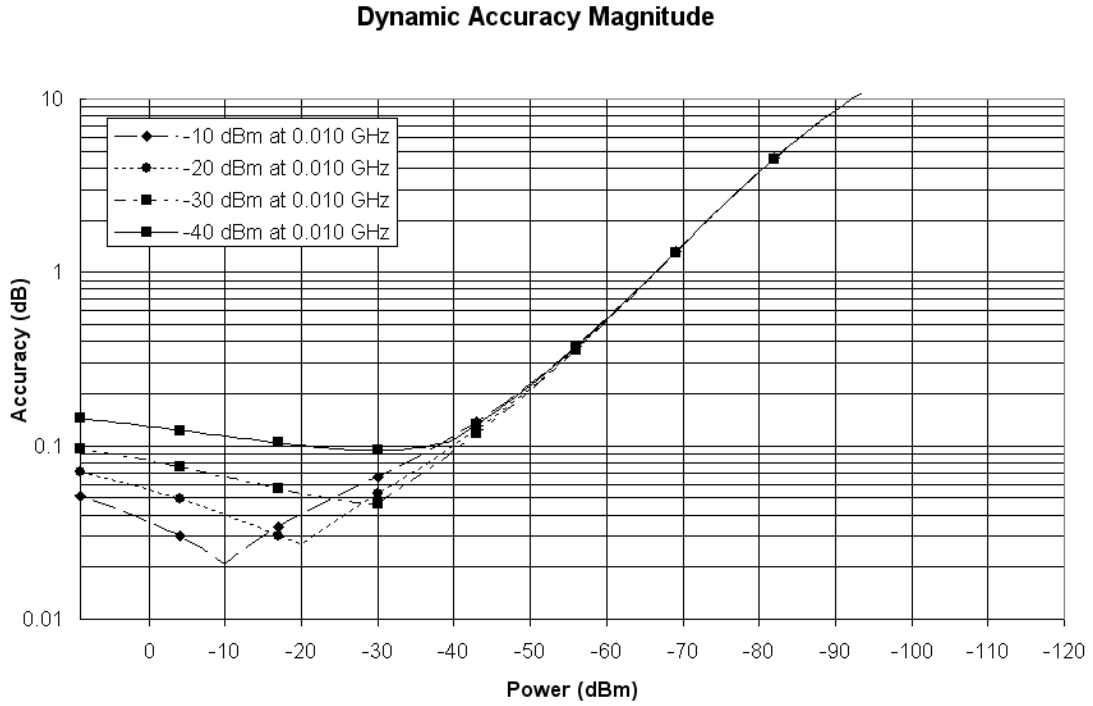

Dynamic Accuracy Magnitude

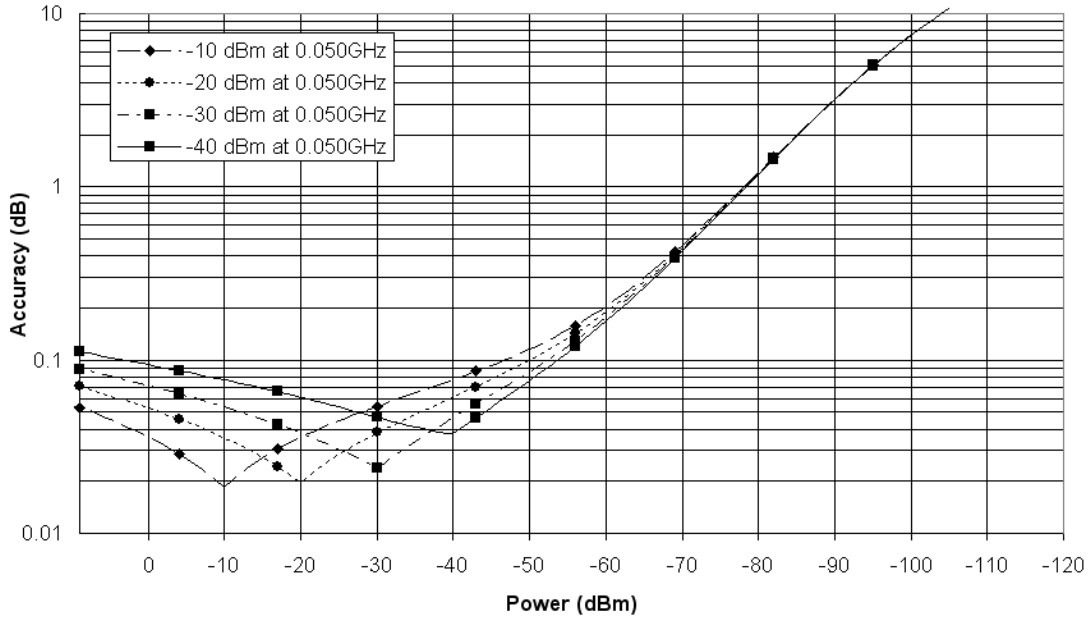

Dynamic Accuracy Phase

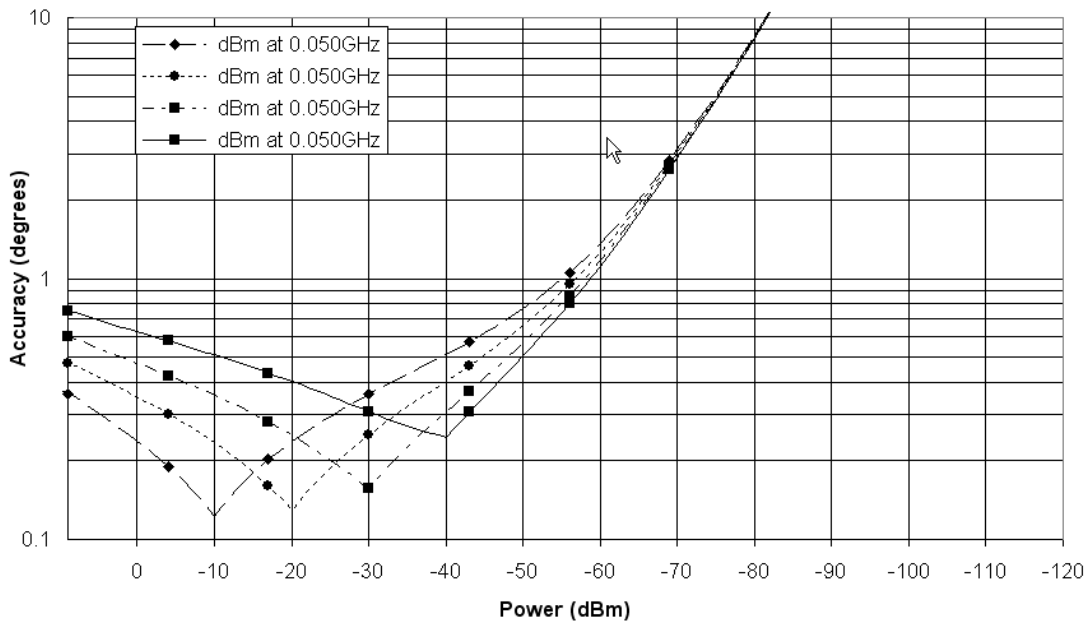

Dynamic Accuracy Magnitude

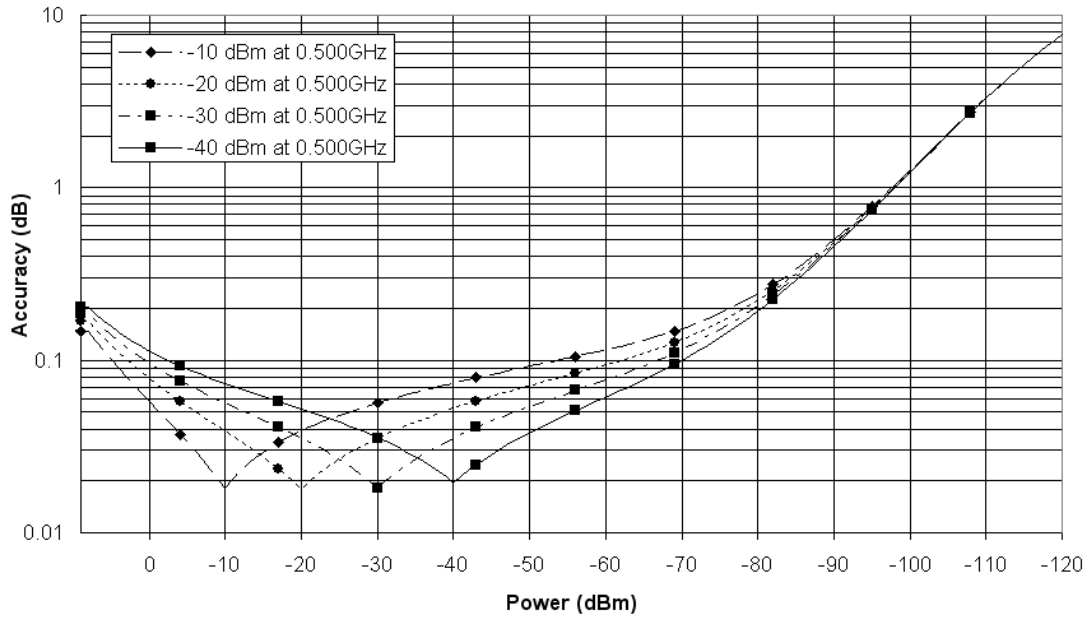

Dynamic Accuracy Phase

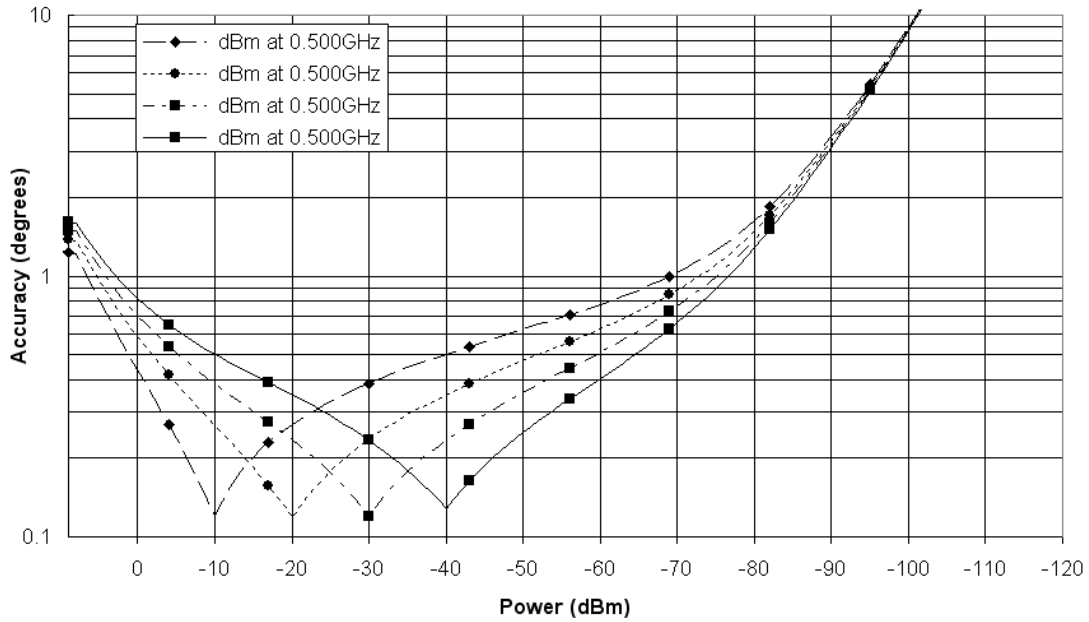

Dynamic Accuracy Magnitude

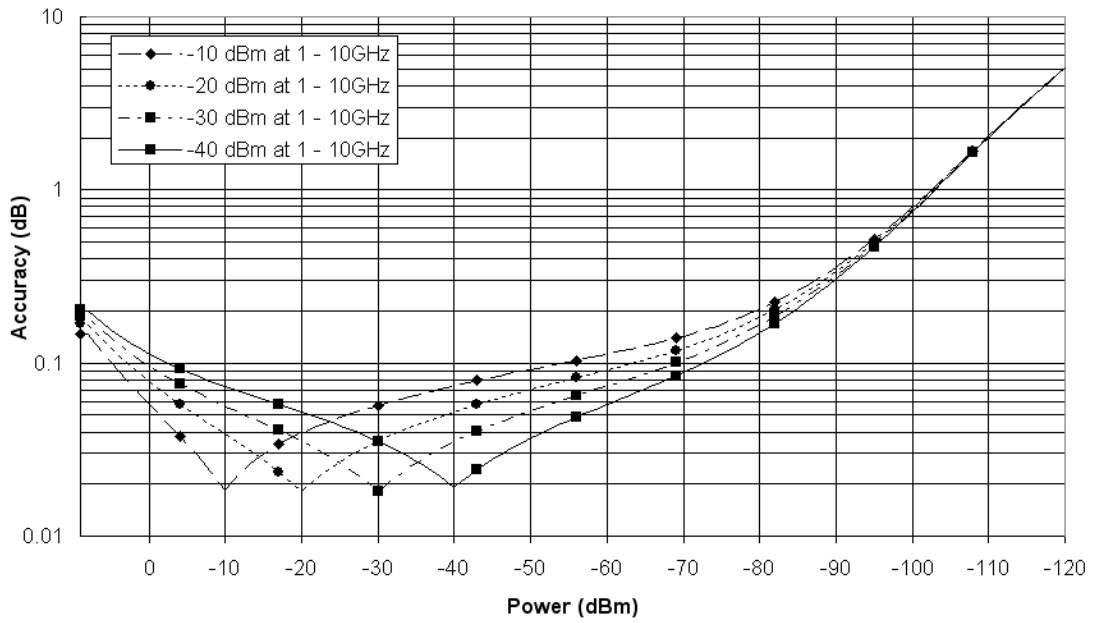

Dynamic Accuracy Phase

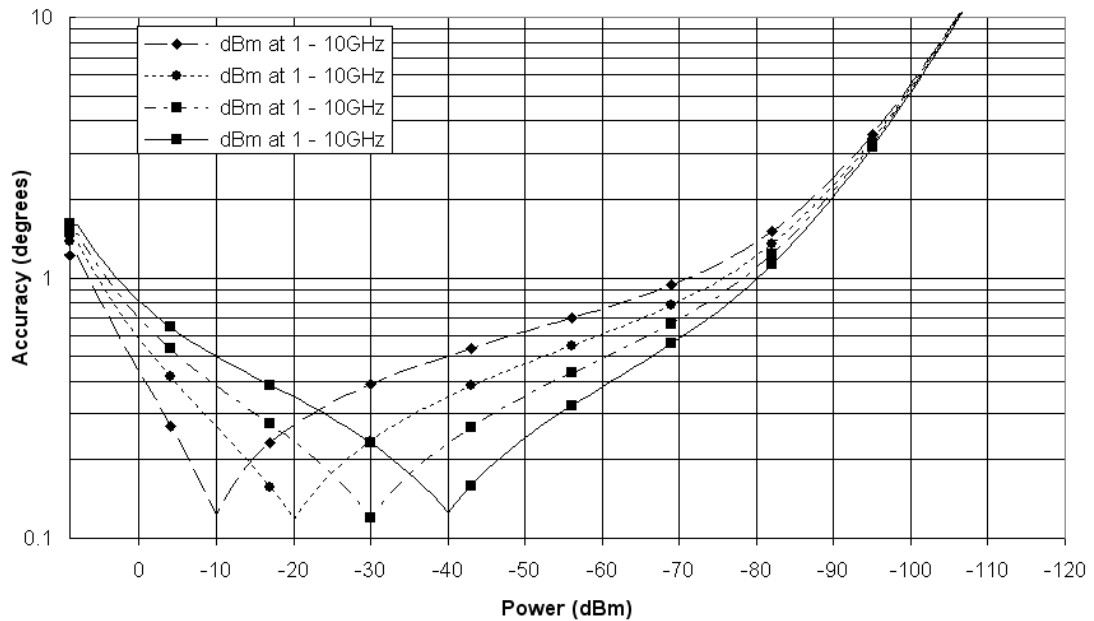

Dynamic Accuracy Magnitude

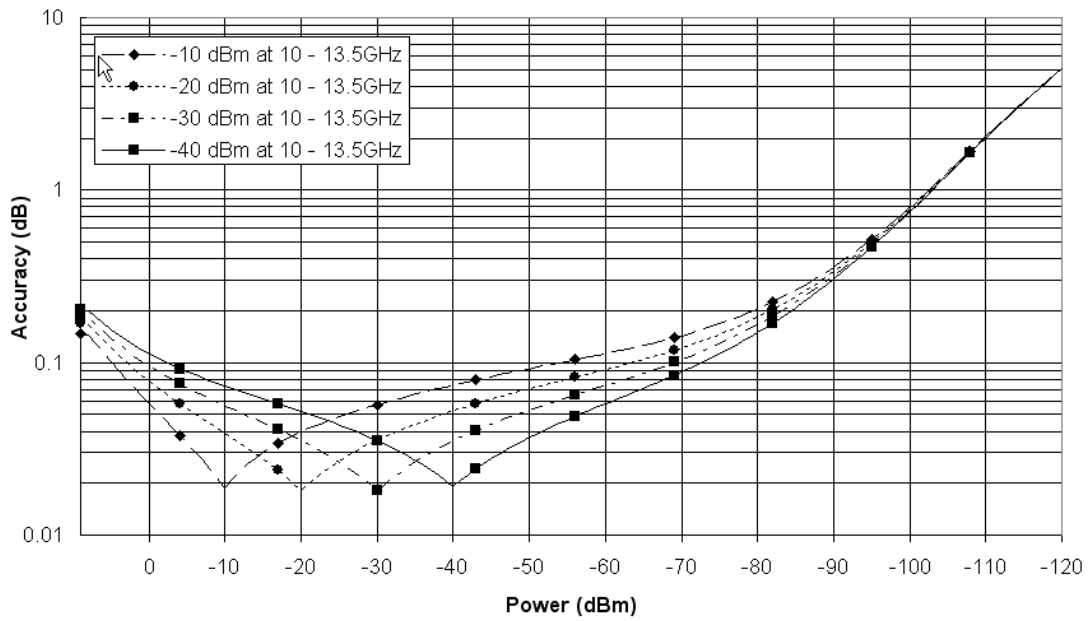

Dynamic Accuracy Phase

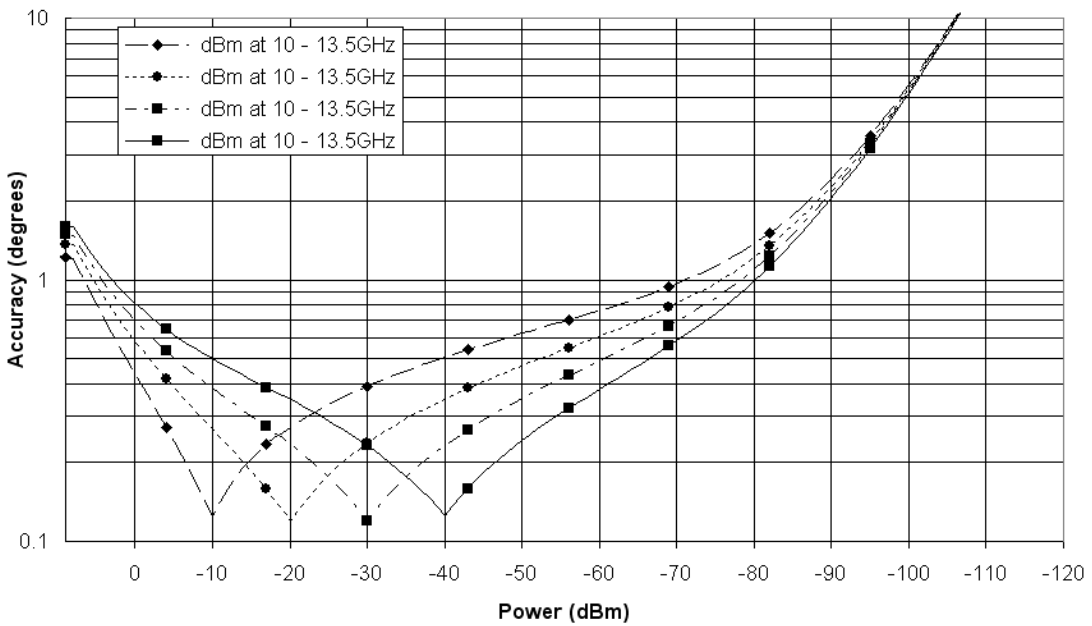

Dynamic Accuracy Magnitude

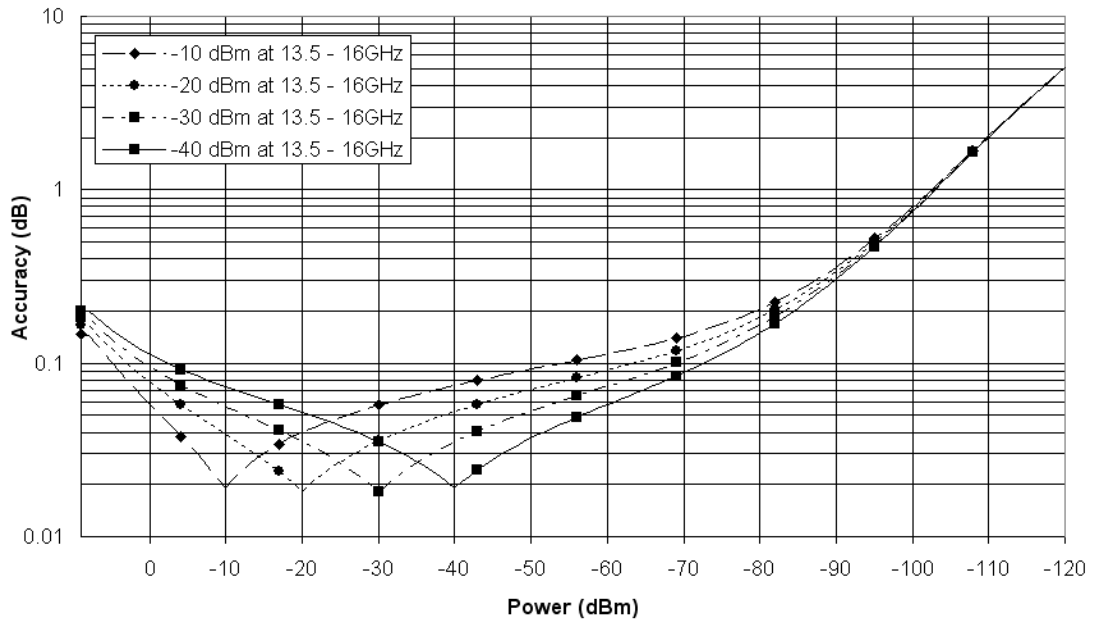

Dynamic Accuracy Phase

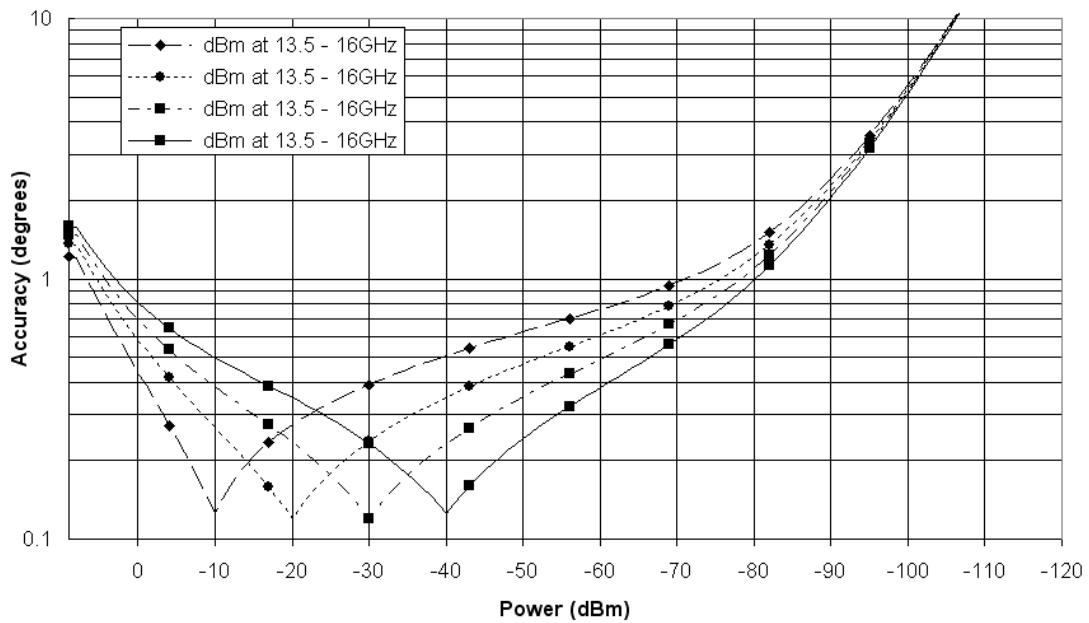

Dynamic Accuracy Magnitude

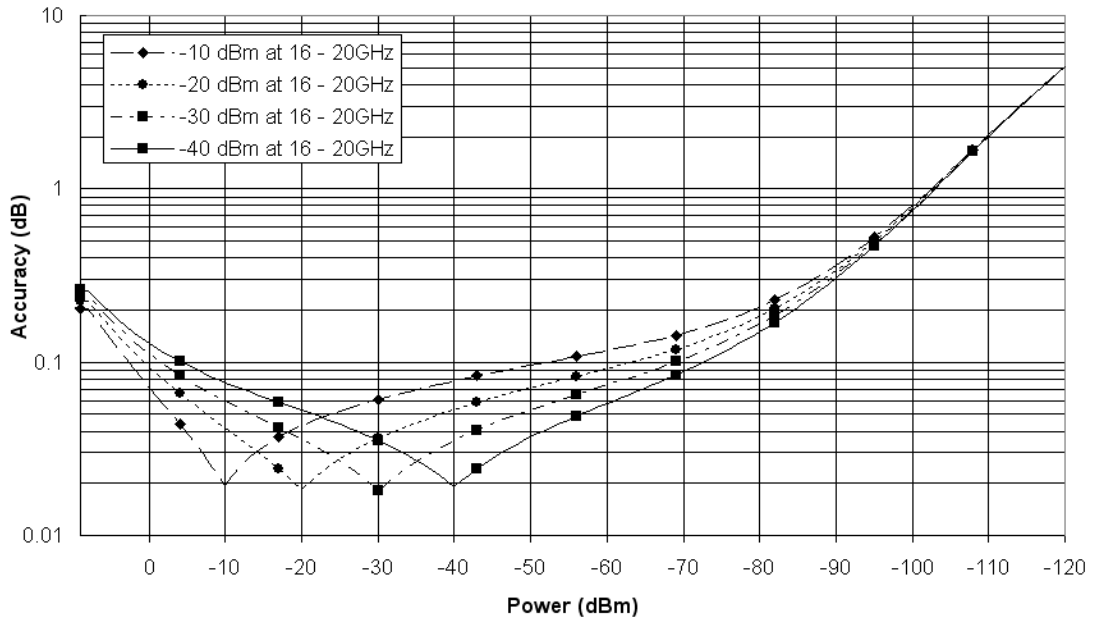

Dynamic Accuracy Phase

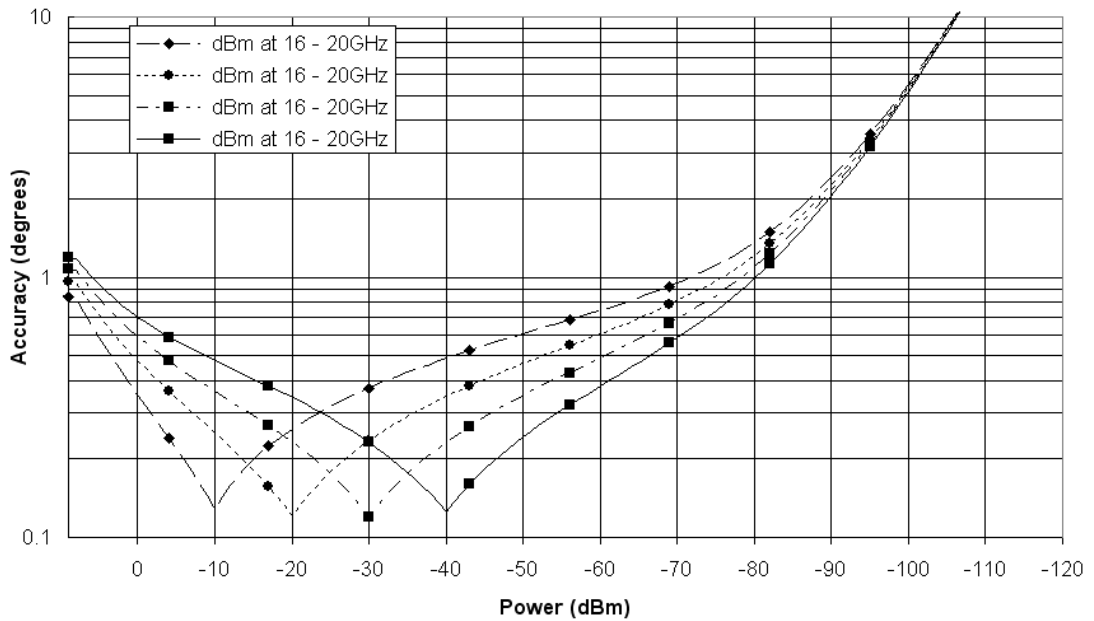

Dynamic Accuracy, 20 - 26.5 GHz

Dynamic Accuracy Magnitude

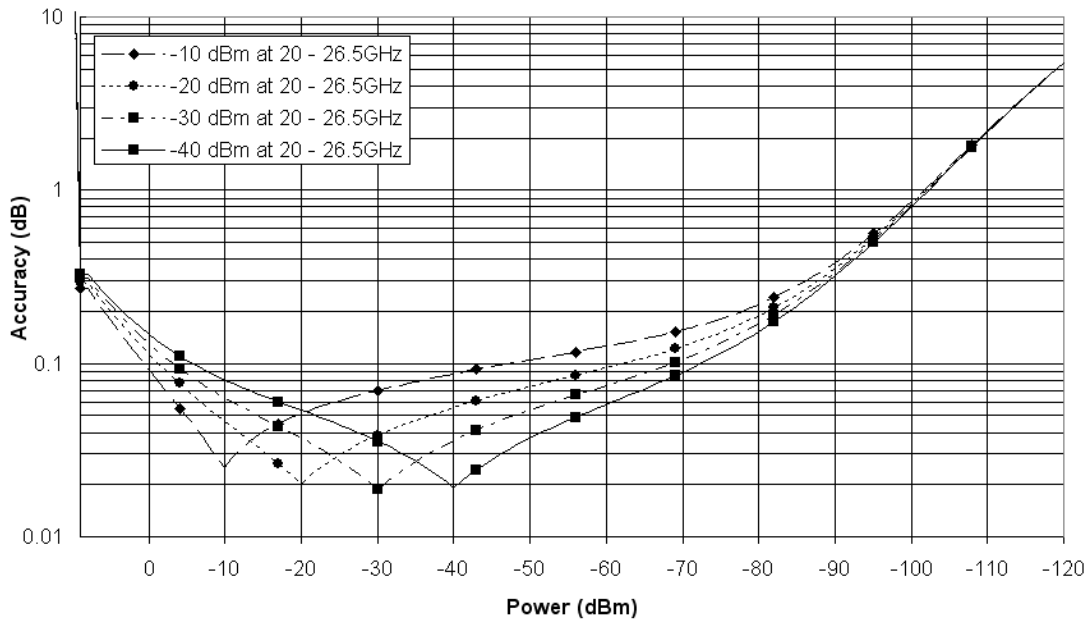

Dynamic Accuracy Phase

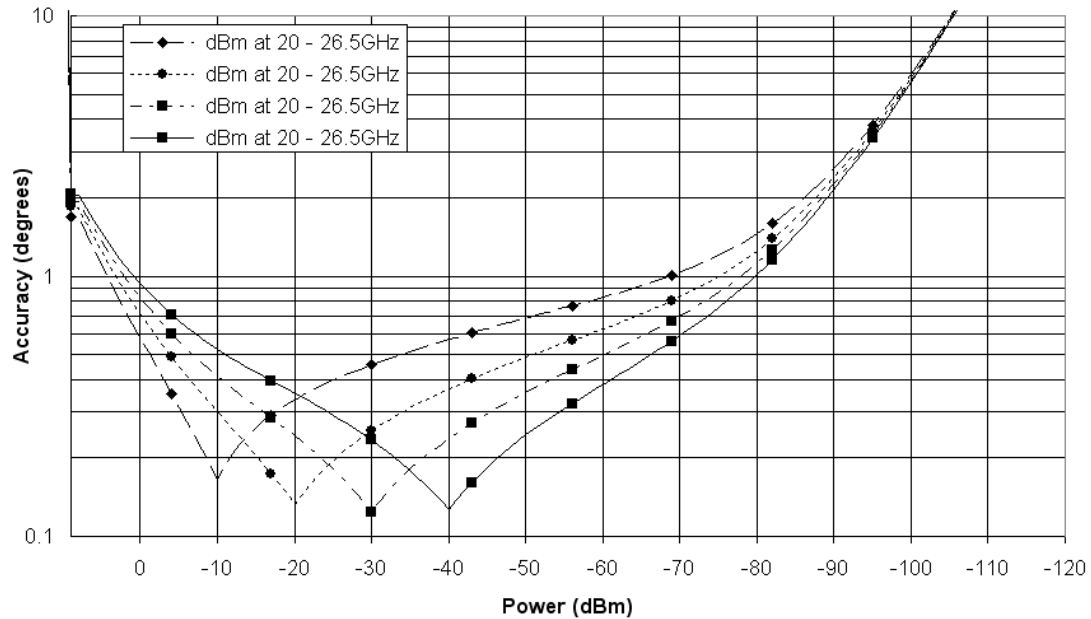

² Dynamic accuracy is verified with the following measurements:

Compression over frequency

IF linearity at a single frequency of 1.195 GHz using a reference level of -20 dBm for an input power range of 0 to -120 dBm.

Table 28. Test Port Input (Group Delay)^a

Description	Typical Performance
Aperture (selectable)	(frequency span)/(number of points -1)
Maximum Aperture	20% of frequency span
Range	0.5 x (1/minimum aperture)
Maximum Delay	Limited to measuring no more than 180° of phase change within the minimum aperture.)
Accuracy	See graph below. Char.

The following graph shows characteristic group delay accuracy with full 2-port calibration and a 10 Hz IF bandwidth. Insertion loss is assumed to be < 2 dB and electrical length to be ten meters.

For any S_{ij} Group Delay measurement, $S_{ii} = 0$, $S_{ij} = 1$, $S_{ji} = 0$, $S_{kl} = 0$ for all $kl \neq ij$

Group Delay (Typical)

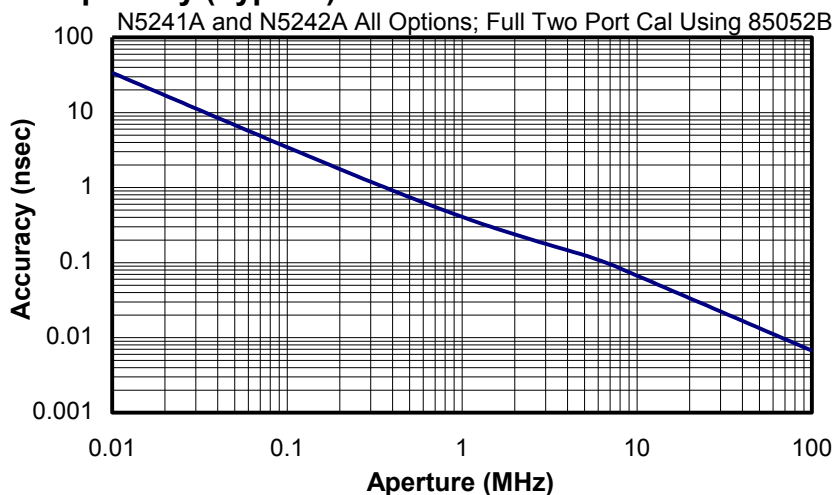

In general, the following formula can be used to determine the accuracy, in seconds, of specific group delay measurement:

$$\pm \text{Phase Accuracy (deg)} / [360 \times \text{Aperture (Hz)}]$$

Depending on the aperture and device length, the phase accuracy used is either incremental phase accuracy or worst-case phase accuracy.

^a Group delay is computed by measuring the phase change within a specified frequency step (determined by the frequency span and the number of points per sweep).

General Information

- [Miscellaneous Information](#)
- [Front Panel](#)
- [Rear Panel](#)
- [Environment and Dimensions](#)

Table 29. Miscellaneous Information

Description	Supplemental Information
System IF Bandwidth Range	1 Hz to 5 MHz, nominal
CPU	Intel® 1.6 GHz Pentium® M with 1 GByte RAM
LXI	Class C (only applies to N5241A and N5242A models that are shipped with firmware revision A.08.20 and higher)

Table 30. Front Panel Information

All Options

Description	Typical Performance
RF Connectors	
Type	Option 200 or 219 or 224 or 400 or 419 or 423: 3.5 mm (male), 50 ohm, (nominal)
Center Pin Recession	0.002 in. (characteristic)
USB 2.0 Ports	
Master (4 ports)	
Standard	Compatible with USB 2.0
Connector	USB Type-A female
Display	
Size	26.3 cm (10.4 in) diagonal color active matrix LCD; 1024 (horizontal) X 768 (vertical) resolution
Refresh Rate	Vertical 60 Hz; Horizontal 46.08 kHz
Pixels	A display is considered faulty if: <ul style="list-style-type: none">• A complete row or column consists of "stuck" or "dark" pixels.• More than six "stuck on" pixels (but not more than three green) or more than 0.002% of the total pixels are within the LCD specifications.• More than twelve "dark" pixels (but no more than seven of the same color) or more than 0.004% of the total pixels are within the LCD specifications.• Two or more consecutive "stuck on" pixels or three or more consecutive "dark" pixel (but no more than one set of two consecutive dark pixels)

• “Stuck on” “dark” pixels are less than 6.5 mm apart (excluding consecutive pixels)

Display Range

Magnitude +/-2500 dB (at 500 dB/div), max

Phase +/-2500° (at 500 dB/div), max

Polar 10 pUnits, min
10,000 Units, max

Display Resolution

Magnitude 0.001 dB/div, min

Phase 0.01°/div, min

Marker Resolution

Magnitude 0.001 dB, min

Phase 0.01°, min

Polar 10 pUnit, min

Table 31. Rear Panel Information**All Options**

Description	Typical Performance
10 MHz Reference In	
Connector	BNC, female
Input Frequency	10 MHz \pm 10 ppm
Input Level	-15 dBm to +20 dBm
Input Impedance	200 Ω , nom.
10 MHz Reference Out	
Connector	BNC, female
Output Frequency	10 MHz \pm 1 ppm
Signal Type	Sine Wave
Output Level	+10 dBm \pm 4 dB into 50 Ω
Output Impedance	50 Ω , nominal
Harmonics	<-40 dBc, typical
External IF Inputs	
Function	Allows use of external IF signals from remote mixers, bypassing the PNA's first converters
Connectors	SMA (female); A, B, C, D, R (4-port); A, B, R1, R2 (2-port)
Input Frequency	
Normal IF path:	RF < 53 MHz: IF = 2.535 MHz RF \geq 53 MHz: IF = 7.606 MHz
Narrowband IF path:	IF = 10.70 MHz
Input Impedance	50 Ω
RF Damage Level	+23 dBm
DC Damage Level	5.5 VDC
0.1 dB Compression Point	-9.0 dBm

Table 31. (Continued) Rear Panel Information

Pulse Inputs (IF Gates)	
Function	Internal receiver gates used for point-in-pulse and pulse-profile measurements
Connectors	15-pin mini D-sub
Input Impedance	1 K Ohm
Minimum Pulse Width, Source Modulators	33 ns
Minimum Pulse Width, Receiver Gates	20 ns
DC Damage Level	5.5 VDC
Drive Voltage	0 V (off), +3.3 V (on), nominal
RF Pulse Modulator Input (Source Modulator)	
On/Off Ratio	
10 MHz to 3.2 GHz	-64
3.2 GHz to 13.5 GHz	-80
13.5 GHz to 26.5 GHz	-80
Pulse Period	
Minimum	33 ns
Maximum	70 s
External Test Set Driver	
Function	Used for driving remote mixers
Connections	SMA (female)
RF, LO Output Frequency Range	1.7 to 13.5 GHz (N5241A) 1.7 to 26.5 GHz (N5242A)

Table 31. (Continued) Rear Panel Information

Description	Typical (dBm)	
	Upper Limit (dBm)	Lower Limit (dBm)
Test Set Drivers (Continued)		
Rear Panel LO Power		
1.7 GHz to 13.5 GHz	0	-10
13.5 GHz to 18 GHz	0	-10
18 GHz to 22.5 GHz	2	-8
22.5 GHz to 26.5 GHz ¹	6	-5
Rear Panel RF Power		
3.2 GHz to 13.5 GHz	-3	-8
13.5 GHz to 20 GHz	-3	-8
20 GHz to 26.5 GHz	-8	-14

¹ Full LO frequency range is:

12.535 MHz to 13.5 GHz. (N5241A)

12.535 MHz to 26.5 GHz. (N5242A)

Table 31. (Continued) Rear Panel Information

Description	Typical Performance
VGA Video Output	
Connector	15-pin mini D-Sub; Drives VGA compatible monitors
Devices Supported:	
	Resolutions:
Flat Panel (TFT)	1024 X 768, 800 X 600, 640 X 480
Flat Panel (DSTN)	800 X 600, 640 X 480
CRT Monitor	1280 X 1024, 1024 X 768, 800 X 600, 640 X 480
	Simultaneous operation of the internal and external displays is allowed, but with 640 X 480 resolution only. If you change resolution, you can only view the external display (internal display will "white out").
Bias Tee Inputs	
Connectors	BNC(f) for ports 1, 2, 3 and 4
Fuse	500 mA, bi-pin style
Maximum Bias Current	+/-200 mA with no degradation of RF specifications
Maximum Bias Voltage	+/-40 VDC
Trigger Inputs/Outputs	BNC(f), TTL/CMOS compatible
Test Set IO	25-pin D-Sub connector, available for external test set control.
Power IO	9-pin D-Sub, female; analog and digital IO
Handler IO	36-pin parallel I/O port; all input/output signals are default set to negative logic; can be reset to positive logic via GPIB command.

Table 31. (Continued) Rear Panel Information

GPIB (two ports - dedicated controller and dedicated talker/listener)	24-pin D-sub (Type D-24), female; compatible with IEEE-488.
Parallel Port (LPT1)	25-pin D-Sub miniature connector, female; provides connection to printers or any other parallel port peripherals
USB Port	Four ports on front panel (all Host) and five ports (four Host and one Device) on rear panel. Type A configuration (eight Host) and Type B configuration (one Device), USB 2.0 compatible.
LAN	10/100BaseT Ethernet, 8-pin configuration; auto selects between the two data rates
Line Power	
Frequency, Voltage	50/60 Hz for 100 240 VAC
	Power supply is auto switching
Max	450 watts

Note: Option H11 is not available with the N5241A and N5242A network analyzer.

Table 32. Analyzer Dimensions and Weight

All N5241A and N5242A models are shipped with bottom feet, handles, and front and rear hardware.

Cabinet Dimensions	Metric (mm)	Imperial (inches)
Height		
Without bottom feet: ¹ EIA RU ¹ = 6	266.1	10.5
With bottom feet	279.1	11.0
Width		
Without handles or rack-mount flanges	425.6	16.8
With handles, without rack-mount flanges	458.7	18.1
With handles and rack-mount flanges	482.9	19.0
Depth		
Without front and rear panel hardware	533.0	21.0
With front and rear panel hardware, handles	578.0	22.7

¹Electronics Industry Association rack units. 1 RU = 1.75 in.

See detailed PNA dimension drawings at: <http://na.tm.agilent.com/pna/PNADimensions.pdf>

Weight			
	Option 200 or 219 or 224	Option 400 or 419 or 423	
Net	27 kg (60 lb), nominal	37 kg (82 lb), nominal	--
Shipping	43 kg (95 lb), nominal	53 kg (117 lb), nominal	--

Operating Environment

For Regulatory and Environmental information, refer to the PNA Series Installation and Quick Start Guide, located online at <http://cp.literature.agilent.com/litweb/pdf/E8356-90001.pdf>.

Measurement Throughput Summary

- [Typical Cycle Time for Measurement Completion](#)
- [Cycle Time vs. IF Bandwidth](#)
- [Cycle Time vs. Number of Points](#)
- [Data Transfer Time](#)

Table 33. Typical Cycle Time^a (ms) for Measurement Completion

All Options

Description	Typical Performance			
	Number of Points			
	201	401	1601	16001
Start 9 GHz, Stop 10 GHz, 600 kHz IF bandwidth				
Uncorrected	6	6.3	9.6	56
2-Port cal	20	21	28	134
Start 9 GHz, Stop 10 GHz, 10 kHz IF bandwidth				
Uncorrected	36	53	200	1945
2-Port cal	80	115	405	3900
Start 9 GHz, Stop 10 GHz, 1 kHz IF bandwidth				
Uncorrected	227	444	1740	17000
2-Port cal	460	900	3484	34000
Start 10 GHz, Stop 13.5 GHz, 600 kHz IF bandwidth				
Uncorrected	26	33	54	85
2-Port cal	62	77	121	190
Start 10 GHz, Stop 13.5 GHz, 10 kHz IF bandwidth				
Uncorrected	70	118	273	1958
2-Port cal	149	245	553	3922
Start 10 GHz, Stop 13.5 GHz, 1 kHz IF bandwidth				
Uncorrected	236	459	1780	17300
2-Port Cal	400	926	3565	34600
Start 13.5 GHz, Stop 20 GHz, 600 kHz IF bandwidth				

Uncorrected	26	33	54	85
2-Port cal	62	77	121	190
Start 13.5 GHz, Stop 20 GHz, 10 kHz IF bandwidth				
Uncorrected	70	118	273	1958
2-Port cal	149	245	553	3922
Start 13.5 GHz, Stop 20 GHz, 1 kHz IF bandwidth				
Uncorrected	236	459	1780	17300
<i>2-Port Cal</i>	400	926	3565	34600

Table 33. (Continued) Typical Cycle Time^a (ms) for Measurement Completion

Start 10 MHz, Stop 26.5 GHz, 600 kHz IF bandwidth				
Uncorrected	59	69	118	350
2-Port cal	125	147	244	707
Start 10 MHz, Stop 26.5 GHz, 10 kHz IF bandwidth				
Uncorrected	94	156	480	2333
2-Port cal	196	320	968	4674
Start 10 MHz, Stop 26.5 GHz, 1 kHz IF bandwidth				
Uncorrected	277	504	1873	17950
2-Port cal	561	1015	3756	35900

^a Includes sweep time, retrace time and band-crossing time. Analyzer display turned off with DISPLAY:ENABLE OFF. Add 21 ms for display on. Data for one trace (S₁₁) measurement.

Note: Option H08 and Option H11 are not available with the N5241A and N5242A network analyzer.

Table 34. Cycle Time vs. IF Bandwidth

Applies to the Preset condition (201 points, correction off) except for the following changes:

- CF = 10 GHz
- Span = 100 MHz
- Display off (add 21 ms for display on)

Description	Typical Performance	
IF Bandwidth (Hz)	Cycle Time (ms) ¹	Trace Noise
600,000	5.00	0.009
100,000	6.84	0.003
30,000	11.6	0.002
10,000	29.0	0.001
3,000	71.8	0.0007
1,000	222	0.0004
300	640	0.0003
100	1826	0.0002
30	5982	<0.0002
10	17830	<0.0002
3	60000	<0.0002

^a Cycle time includes sweep and retrace time.

Table 35. Cycle Time vs. Number of Points

Applies to the Preset condition (correction off) except for the following changes:

- CF = 10 GHz
- Span = 100 MHz
- Display off (add 21 ms for display on)

Description	Typical Performance	
IF Bandwidth (Hz)	Number of Points	Cycle Time (ms) ¹
1,000	3	7.7
	11	16.6
	51	60
	101	115
	201	222
	401	436
	801	860
	1,601	1,700
	6,401	6,700
	16,001	16,000
10,000	3	5.44
	11	7.90
	51	10.7
	101	16.8
	201	29.0
	401	53.0
	801	102
	1,601	199
	6,401	780
	16,001	1950

Table 35. (Continued) Cycle Time Vs. Number of Points

Description	Typical Performance	
IF Bandwidth (Hz)	Number of Points	Cycle Time (ms) ¹
30,000	3	5.7
	11	5.9
	51	6.5
	101	8.2
	201	11.8
	401	18.8
	801	32.8
	1,601	60.5
	6,401	228
	16,001	566
600,000	3	5.4
	11	5.4
	51	5.5
	101	5.6
	201	5.9
	401	6.3
	801	7.2
	1,601	9.6
	6,401	25
	16,001	56

^a Cycle time includes sweep and retrace time.

Table 36. Data Transfer Time (ms)

Description	Typical Performance			
	Number of Points			
	201	401	1601	16,001
SCPI over GPIB				
(Program executed on external PC ²)				
32-bit floating point	5.6	10.5	39.9	400
64-bit floating point	10.5	20.3	79.2	788
ASCII	46	92.5	370	3702
SCPI over SICL/LAN or TCP/IP Socket				
(Program executed in the analyzer)				
32-bit floating point	0.18	0.21	0.5	3.6
64-bit floating point	0.22	0.28	0.62	5.3
ASCII	6.3	12.3	47.3	470
COM³				
(Program executed in the analyzer)				
32-bit floating point	<0.15	0.15	0.2	0.7
Variant type	0.75	1.2	4.5	50
DCOM over LAN³				
(Program executed on external PC)				
32-bit floating point	<1.0	1.2	2.1	13
Variant type	2.7	4.5	15	150

¹ Measured with the analyzer display off. Values will increase slightly if the analyzer display is on.

² Measured when using the SCPI command DISPlay: VISible OFF.

³ Values are for real and imaginary pairs, with the analyzer display off.

Note: Specifications for Recall & Sweep Speed are not provided for the N5241A and N5242A analyzers.

Front-Panel Jumpers

Model N5241A and N5242A (PNA-X)

Note: All PNA-X options have the following front-panel jumpers for each port.



- [Measurement Receiver Inputs](#)
- [Reference Receiver Inputs](#)
- [Reference Outputs \(Source Out\)](#)
- [Source Outputs](#)
- [Coupler Inputs](#)

Table 37. Measurement Receiver Inputs**(Rcvr A IN, Rcvr B IN, Rcvr C IN, Rcvr D IN) @ 0.1dB Typical Compression**

Description	Typical
	All Options
Maximum Input Level	
10 MHz to 50 MHz ¹	--
50 MHz to 500 MHz ¹	--
500 MHz to 3.2 GHz	-2 dBm
3.2 GHz to 10 GHz	-2 dBm
10 GHz to 13.5 GHz	-2 dBm
13.5 GHz to 16 GHz	-2 dBm
16 GHz to 20 GHz	-2.5 dBm
20 GHz to 24 GHz	-4 dBm
24 GHz to 26.5 GHz	-4 dBm
Damage Level	
	+15 dBm
Maximum DC Level	
	0 V

¹Test port receiver compression at specified input levels below 500 MHz is negligible due to coupler roll off in this frequency range.

Table 38. Reference Receiver Input
(RCVR R1 IN) @ Max Specified Output Power

Description	Typical					
	Option 200 or 400 Filtered Mode	Option 200 or 400 Hi Pwr Mode	Option 224 or 423 Filtered Mode	Option 219 or 419 Filtered Mode	Option 219 or 419 Hi Pwr Mode	Option 224 or 423 Hi Pwr Mode
Maximum Input Level						
10 MHz to 50 MHz	-8 dBm	-3 dBm	-9 dBm	-8 dBm	-3 dBm	-6 dBm
50 MHz to 500 MHz	-6 dBm	-3 dBm	-7 dBm	-6 dBm	-3 dBm	-5 dBm
500 MHz to 3.2 GHz	-6 dBm	-6 dBm	-7 dBm	-5 dBm	-5 dBm	-5 dBm
3.2 GHz to 10 GHz	-3 dBm	-3 dBm	-2 dBm	-2 dBm	-2 dBm	-2 dBm
10 GHz to 13.5 GHz	-4 dBm	-4 dBm	-3 dBm	-3 dBm	-3 dBm	-3 dBm
13.5 GHz to 16 GHz	-4 dBm	-4 dBm	-3 dBm	-3 dBm	-3 dBm	-3 dBm
16 GHz to 20 GHz	-5 dBm	-5 dBm	-6 dBm	-6 dBm	-6 dBm	-6 dBm
20 GHz to 24 GHz	-7 dBm	-7 dBm	-9 dBm	-8 dBm	-8 dBm	-9 dBm
24 GHz to 26.5 GHz	-16 dBm	-16 dBm	-18 dBm	-15 dBm	-15 dBm	-18 dBm
Damage Level						
+15 dBm						
Maximum DC Level						
+/-7 V						

Table 39. Reference Receiver Input**(RCVR R2 IN, RCVR R3 IN, RCVR R4 IN) @ Max Specified Output Power**

Description	Typical					
	Option 400 RCVR R3 IN Filtered Mode	Option 400 RCVR R3 IN Hi Pwr Mode	Option 200 or 400 RCVR R2 IN RCVR R4 IN	Option 419 RCVR R3 IN Filtered Mode	Option 419 RCVR R3 IN Hi Pwr Mode	Option 219 or 419 RCVR R2 IN RCVR R4 IN
Maximum Input Level						
10 MHz to 50 MHz	-6 dBm	-1 dBm	-1 dBm	-6 dBm	-1 dBm	-1 dBm
50 MHz to 500 MHz	-4 dBm	-1 dBm	-1 dBm	-4 dBm	-1 dBm	-1 dBm
500 MHz to 3.2 GHz	-4 dBm	-4 dBm	0 dBm	-3 dBm	-3 dBm	-1 dBm
3.2 GHz to 10 GHz	0 dBm	0 dBm	0 dBm	1 dBm	1 dBm	0 dBm
10 GHz to 13.5 GHz	1 dBm	1 dBm	0 dBm	1 dBm	1 dBm	1 dBm
13.5 GHz to 16 GHz	1 dBm	1 dBm	0 dBm	1 dBm	1 dBm	1 dBm
16 GHz to 20 GHz	1 dBm	1 dBm	-3 dBm	0 dBm	0 dBm	-3 dBm
20 GHz to 24 GHz	0 dBm	0 dBm	-6 dBm	-1 dBm	-1 dBm	-4 dBm
24 GHz to 26.5 GHz	-8 dBm	-8 dBm	-12 dBm	-7 dBm	-7 dBm	-13 dBm
Damage Level						
	+15 dBm					
Maximum DC Level						
	+/-15 V					

Table 39. (Continued) Reference Receiver Input
(RCVR R2 IN, RCVR R3 IN, RCVR R4 IN) @ Max Specified Output Power

Description	Typical		
	Option 423 RCVR R3 IN Filtered Mode	Option 423 RCVR R3 IN Hi Pwr Mode	Option 224 or 423 RCVR R2 IN RCVR R4 IN Filtered Mode Note: No filtered mode for ports 2 & 4
Maximum Input Level			
10 MHz to 50 MHz	-7 dBm	-4 dBm	-1 dBm
50 MHz to 500 MHz	-6 dBm	-4 dBm	-1 dBm
500 MHz to 3.2 GHz	-5 dBm	-3 dBm	-1 dBm
3.2 GHz to 10 GHz	1 dBm	1 dBm	0 dBm
10 GHz to 13.5 GHz	1 dBm	1 dBm	-2 dBm
13.5 GHz to 16 GHz	1 dBm	1 dBm	-2 dBm
16 GHz to 20 GHz	0 dBm	0 dBm	-4 dBm
20 GHz to 24 GHz	-2 dBm	-2 dBm	-6 dBm
24 GHz to 26.5 GHz	-10 dBm	-10 dBm	-10 dBm
Damage Level			
	+15 dBm		
Maximum DC Level			
	+/-15 V		

Table 40. Reference Output**(REF 1 SOURCE OUT) @ Max Specified Output Power**

Description	Typical					
	Option 200 or 400 Filtered Mode	Option 200 or 400 Hi Pwr Mode	Option 219 or 419 Filtered Mode	Option 219 or 419 Hi Pwr Mode	Option 224 or 423 Filtered Mode	Option 224 or 423 Hi Pwr Mode
Maximum Input Level						
10 MHz to 50 MHz	-8 dBm	-3 dBm	-8 dBm	-3 dBm	-9 dBm	-6 dBm
50 MHz to 500 MHz	-6 dBm	-3 dBm	-6 dBm	-3 dBm	-7 dBm	-5 dBm
500 MHz to 3.2 GHz	-6 dBm	-6 dBm	-5 dBm	-5 dBm	-7 dBm	-5 dBm
3.2 GHz to 10 GHz	-3 dBm	-3 dBm	-2 dBm	-2 dBm	-2 dBm	-2 dBm
10 GHz to 13.5 GHz	-4 dBm	-4 dBm	-3 dBm	-3 dBm	-3 dBm	-3 dBm
13.5 GHz to 16 GHz	-4 dBm	-4 dBm	-3 dBm	-3 dBm	-3 dBm	-3 dBm
16 GHz to 20 GHz	-5 dBm	-5 dBm	-6 dBm	-6 dBm	-6 dBm	-6 dBm
20 GHz to 24 GHz	-7 dBm	-7 dBm	-8 dBm	-8 dBm	-9 dBm	-9 dBm
24 GHz to 26.5 GHz	-16 dBm	-16 dBm	-15 dBm	-15 dBm	-18 dBm	-18 dBm
Damage Level						
+15 dBm						
Maximum DC Level						
+/-7 V						

Table 41. Reference Output

(REF 2 SOURCE OUT, REF 3 SOURCE OUT, REF 4 SOURCE OUT) @ Max Specified Output Power

Description	Typical					
	Option 400 REF 3 Source Out Filtered Mode	Option 400 REF 3 Source Out Hi Pwr Mode	Option 200 or 400 REF 2 Source Out REF 4 Source Out Filtered Mode	Option 419 REF 3 Source Out Filtered Mode	Option 419 REF 3 Source Out Hi Pwr Mode	Option 219 or 419 REF 2 Source Out REF 4 Source Out Filtered Mode
Maximum Input Level						
10 MHz to 50 MHz	-6 dBm	-1 dBm	-1 dBm	-6 dBm	-1 dBm	-1 dBm
50 MHz to 500 MHz	-4 dBm	-1 dBm	-1 dBm	-4 dBm	-1 dBm	-1 dBm
500 MHz to 3.2 GHz	-4 dBm	-4 dBm	0 dBm	-3 dBm	-3 dBm	-1 dBm
3.2 GHz to 10 GHz	0 dBm	0 dBm	0 dBm	1 dBm	1 dBm	0 dBm
10 GHz to 13.5 GHz	1 dBm	1 dBm	1 dBm	1 dBm	1 dBm	1 dBm
13.5 GHz to 16 GHz	1 dBm	1 dBm	0 dBm	1 dBm	1 dBm	1 dBm
16 GHz to 20 GHz	1 dBm	1 dBm	-3 dBm	0 dBm	0 dBm	-3 dBm
20 GHz to 24 GHz	0 dBm	0 dBm	-6 dBm	-1 dBm	-1 dBm	-4 dBm
24 GHz to 26.5 GHz	-8 dBm	-8 dBm	-12 dBm	-7 dBm	-7 dBm	-13 dBm
Damage Level						
	+15 dBm					
Maximum DC Level						
	0 V					

Table 41. (Continued) Reference Output

(REF 2 SOURCE OUT, REF 3 SOURCE OUT, REF 4 SOURCE OUT) @ Max Specified Output Power

Description	Typical		
	Option423 REF 3 Source Out Filtered Mode	Options 423 REF 3 Source Out Hi Pwr Mode	Option 224 or 423 REF 2 Source Out REF 4 Source Out
Maximum Input Level			
10 MHz to 50 MHz	-7 dBm	-4 dBm	-1 dBm
50 MHz to 500 MHz	-6 dBm	-4 dBm	-1 dBm
500 MHz to 3.2 GHz	-5 dBm	-3 dBm	-1 dBm
3.2 GHz to 10 GHz	1 dBm	1 dBm	0 dBm
10 GHz to 13.5 GHz	1 dBm	1 dBm	-2 dBm
13.5 GHz to 16 GHz	1 dBm	1 dBm	-2 dBm
16 GHz to 20 GHz	0 dBm	0 dBm	-4 dBm
20 GHz to 24 GHz	-2 dBm	-2 dBm	-6 dBm
24 GHz to 26.5 GHz	-10 dBm	-10 dBm	-10 dBm
Damage Level			
	+15 dBm		
Maximum DC Level			
	0 V		

Table 42. Source Outputs

(PORT 1 SOURCE OUT, PORT 2 SOURCE OUT, PORT 3 SOURCE OUT, PORT 4 SOURCE OUT) @ Max Specified Output Power

Description	Typical					
	Option 200 or 400 Port 1 Source Out Port 3 Source Out Filtered Mode	Option 200 or 400 Port 1 Source Out Port 3 Source Out Hi Pwr Mode	Option 200 or 400 Port 2 Source Out Port 4 Source Out	Option 219 or 419 Port 1 Source Out Port 3 Source Out Filtered Mode	Option 219 or 419 Port 1 Source Out Port 3 Source Out Hi Pwr Mode	Option 219 or 419 Port 2 Source Out Port 4 Source Out
Maximum Input Level						
10 MHz to 50 MHz	8 dBm	13 dBm	13 dBm	8 dBm	13 dBm	13 dBm
50 MHz to 500 MHz	10 dBm	13 dBm	13 dBm	10 dBm	13 dBm	13 dBm
500 MHz to 3.2 GHz	11 dBm	11 dBm	13 dBm	11 dBm	11 dBm	14 dBm
3.2 GHz to 10 GHz	14 dBm	14 dBm	14 dBm	14 dBm	14 dBm	14 dBm
10 GHz to 13.5 GHz	14 dBm	14 dBm	14 dBm	14 dBm	14 dBm	13 dBm
13.5 GHz to 16 GHz	14 dBm	14 dBm	14 dBm	14 dBm	14 dBm	13 dBm
16 GHz to 20 GHz	14 dBm	14 dBm	11 dBm	12 dBm	12 dBm	10 dBm
20 GHz to 24 GHz	13 dBm	13 dBm	9 dBm	10 dBm	10 dBm	9 dBm
24 GHz to 26.5 GHz	7 dBm	7 dBm	4 dBm	5 dBm	5 dBm	2 dBm
Damage Level						
	+30 dBm					
Maximum DC Level						
	0 V					

Table 42. (Continued) Source Outputs**(PORT 1 SOURCE OUT, PORT 2 SOURCE OUT, PORT 3 SOURCE OUT, PORT 4 SOURCE OUT) @ Max Specified Output Power**

Description	Typical		
	Option 224 or 423 Port 1 Source Out Port 3 Source Out Filtered Mode	Option 224 or 423 Port 1 Source Out Port 3 Source Out Hi Pwr Mode	Option 224 or 423 Port 2 Source Out Port 4 Source Out
Maximum Input Level			
10 MHz to 50 MHz	7 dBm	10 dBm	13 dBm
50 MHz to 500 MHz	8 dBm	10 dBm	13 dBm
500 MHz to 3.2 GHz	9 dBm	11 dBm	14 dBm
3.2 GHz to 10 GHz	14 dBm	14 dBm	14 dBm
10 GHz to 13.5 GHz	14 dBm	14 dBm	12 dBm
13.5 GHz to 16 GHz	14 dBm	14 dBm	12 dBm
16 GHz to 20 GHz	12 dBm	12 dBm	9 dBm
20 GHz to 24 GHz	9 dBm	9 dBm	7 dBm
24 GHz to 26.5 GHz	2 dBm	2 dBm	4 dBm
Damage Level			
	+30 dBm		
Maximum DC Level			
	0 V		

Table 43. Coupler Inputs**(PORT 1 CPLR THRU, PORT 2 CPLR THRU, PORT 3 CPLR THRU, PORT 4 CPLR THRU) Insertion Loss of Coupler Thru**

Description	Typical	
	Option 200 or 400	Option 219 or 419 or 224, or 423
Maximum Input Level		
10 MHz to 50 MHz	0 dB	-0.5 dB
50 MHz to 500 MHz	-0.25 dB	-0.75 dB
500 MHz to 3.2 GHz	-0.5 dB	-1.0 dB
3.2 GHz to 10 GHz	-0.75 dB	-1.25 dB
10 GHz to 13.5 GHz	-1.0 dB	-1.75 dB
13.5 GHz to 16 GHz	-1.0 dB	-1.75 dB
16 GHz to 20 GHz	-1.5 dB	-2.25 dB
20 GHz to 24 GHz	-1.5 dB	-2.5 dB
24 GHz to 26.5 GHz	-1.75 dB	-2.5 dB
Damage Level		
	+30 dBm	
Maximum DC Level		
	+/-40 V	

N5241A and N5242A Option 029

General specifications apply to Option 029 with the port 1 noise tuner switch set to the internal position except as stated below. By default, the switch is set to the external position to ensure functional compatibility with existing PNA instruments. Refer to the Help System topic “Noise Figure Application” for information on setting the switch position.

Corrected System Performance with 3.5mm Connectors

Note: For any S_{ii} reflection measurement:

- $S_{jj} = 0$.

For any S_{ij} transmission measurement:

- $S_{ji} = S_{ij}$ when $S_{ij} \leq 1$
- $S_{ji} = 1/S_{ij}$ when $S_{ij} > 1$
- $S_{kk} = 0$ for all k

Table 44. 85052B Calibration Kit

N5241A and N5242A Option 029

Applies to the N5241A and N5242A analyzer with Option 029, an 85052B (3.5mm) calibration kit, an 85131F flexible test port cable set, and a full 2-port calibration. S-parameter measurements were made with the analyzer in the noise figure configuration. Environmental temperature $23^\circ \pm 3^\circ \text{C}$, with $< 1^\circ \text{C}$ deviation from calibration temperature.

Description	Specification (dB)				
	50 MHz to 500 MHz	500 MHz to 2 GHz	2 GHz to 13.5 GHz	13.5 GHz to 20 GHz	20 GHz to 26.5 GHz
Directivity	48	48	44	44	44
Source Match	40	40	31	31	31
Load Match	48	48	44	44	44
Reflection Tracking ¹	± 0.003 $+0.010/^\circ\text{C}$	± 0.003 $+0.010/^\circ\text{C}$	± 0.006 $+0.020/^\circ\text{C}$	± 0.006 $+0.020/^\circ\text{C}$	± 0.006 $+0.030/^\circ\text{C}$
S_{21} Transmission Tracking ¹	± 0.033 $+0.010/^\circ\text{C}$	± 0.045 $+0.010/^\circ\text{C}$	± 0.158 $+0.020/^\circ\text{C}$	± 0.158 $+0.020/^\circ\text{C}$	± 0.159 $+0.030/^\circ\text{C}$
S_{12} Transmission Tracking ¹	± 0.044 $+0.010/^\circ\text{C}$	± 0.049 $+0.010/^\circ\text{C}$	± 0.159 $+0.020/^\circ\text{C}$	± 0.159 $+0.020/^\circ\text{C}$	± 0.155 $+0.030/^\circ\text{C}$

¹Temperature deviation is a characteristic value.

Specifications: N5241A and N5242A Option 029 (continued)

Transmission Uncertainty (S21)

The following charts were generated for Opt 423 / 029 although they are applicable for any option including Opt 029.

N5241A Opt 423 / 029 with 85052B (S21)

Magnitude

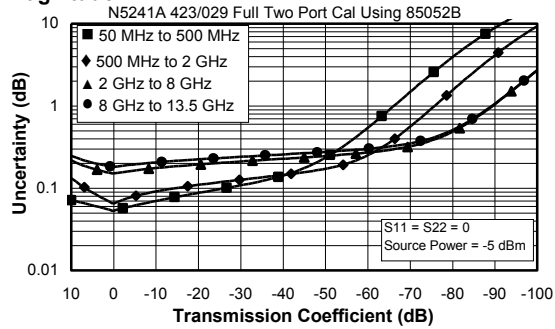

Phase

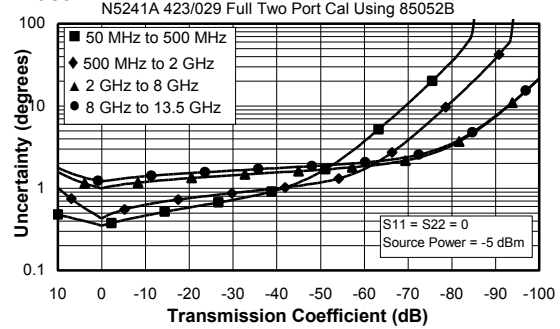

N5242 Opt 423 / 029 with 85052B (S21)

Magnitude

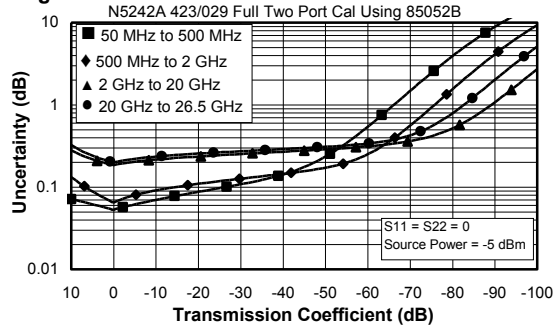

Phase

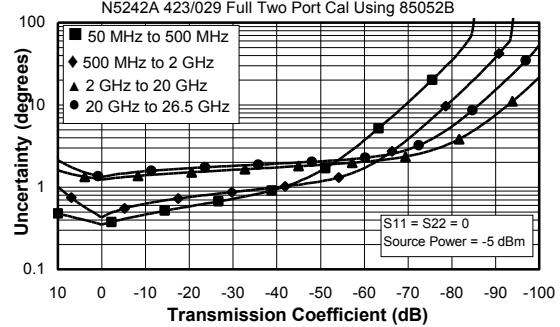

Specifications: N5241A and N5242A Option 029 (continued)

Transmission Uncertainty (S12)

The following charts were generated for Opt 423 / 029 although they are applicable for any option including Opt 029.

N5241A Opt 423 / 029 with 85052B (S12)

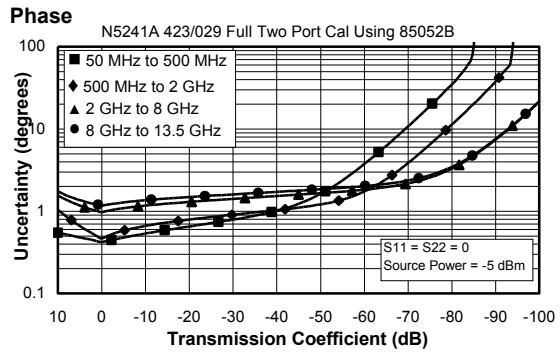
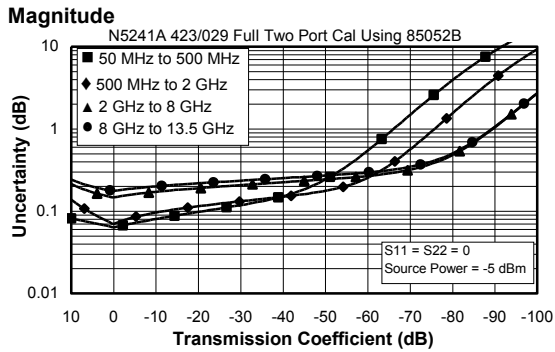

N5242 Opt 423 / 029 with 85052B (S12)

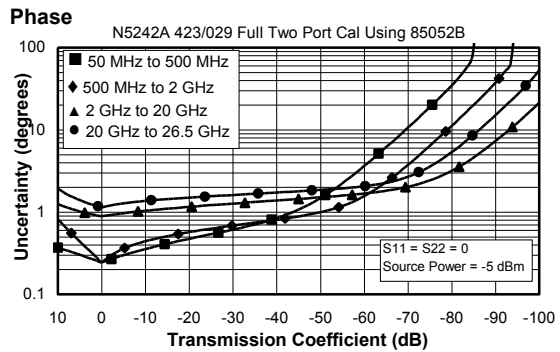
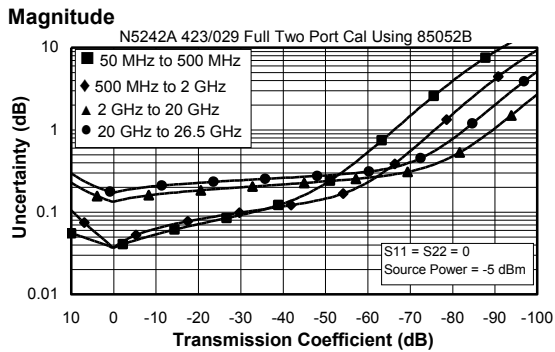

Specifications: N5241A and N5242A Option 029 (continued)

Reflection Uncertainty

The following charts were generated for Opt 423 / 029 although they are applicable for any option including Opt 029.

N5241A Opt 423 / 029 with 85052B

Magnitude

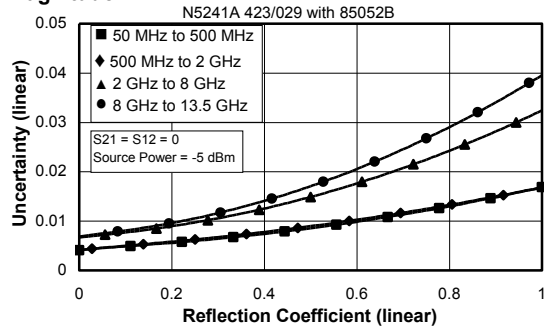

Phase

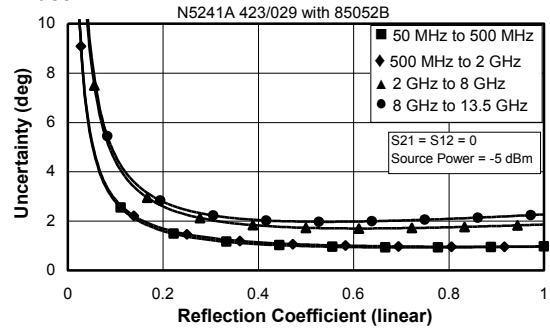

N5242 Opt 423 / 029 with 85052B

Magnitude

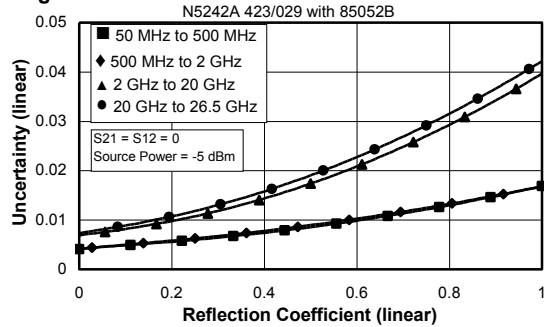

Phase

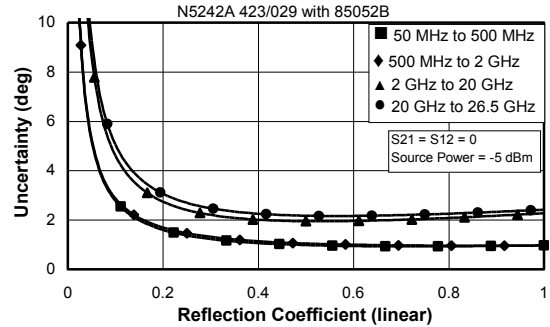

Table 45. N4433A 4-Port Electronic Calibration Module**N5241A and N5242A Option 029**

Note: Uncertainty curves for the N4433A are created using a 2-port calibration. Multipoint uncertainties are not supported at this time.

Applies to the N5241A and N5242A analyzer with Option 029, an N4433A (3.5mm) electronic calibration module, an 85131F flexible test port cable set, and a full 2-port calibration. S-parameter measurements were made with the analyzer in the noise figure configuration. Environmental temperature $23^{\circ} \pm 3^{\circ} \text{C}$, with $< 1^{\circ} \text{C}$ deviation from calibration temperature

Description	Specification (dB)			
	50 MHz to 500 MHz	500 MHz to 2 GHz	2 GHz to 13.5 GHz	13.5 GHz to 20 GHz
Directivity	52	52	45	45
Source Match	42	42	31	31
Load Match	40	40	28	28
Reflection Tracking ¹	± 0.060 $+0.010/^{\circ}\text{C}$	± 0.060 $+0.010/^{\circ}\text{C}$	± 0.180 $+0.020/^{\circ}\text{C}$	± 0.180 $+0.020/^{\circ}\text{C}$
S ₂₁ Transmission Tracking ¹	± 0.065 $+0.010/^{\circ}\text{C}$	± 0.068 $+0.010/^{\circ}\text{C}$	± 0.205 $+0.020/^{\circ}\text{C}$	± 0.205 $+0.020/^{\circ}\text{C}$
S ₁₂ Transmission Tracking ¹	± 0.069 $+0.010/^{\circ}\text{C}$	± 0.069 $+0.010/^{\circ}\text{C}$	± 0.206 $+0.020/^{\circ}\text{C}$	± 0.206 $+0.020/^{\circ}\text{C}$

¹ Temperature deviation is a characteristic value.

Specifications: N5241A and N5242A Option 029 (continued)

Transmission Uncertainty (S21)

The following charts were generated for Opt 423 / 029 although they are applicable for any option including Opt 029.

N5241A Opt 423 / 029 with N4433A (S21)

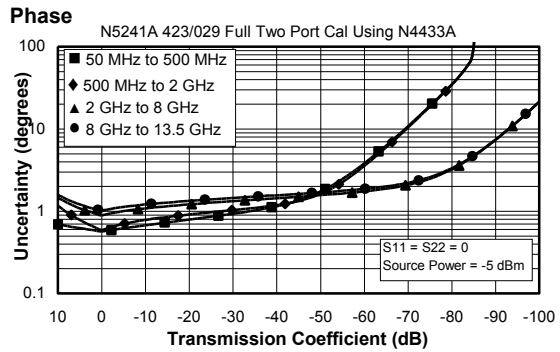
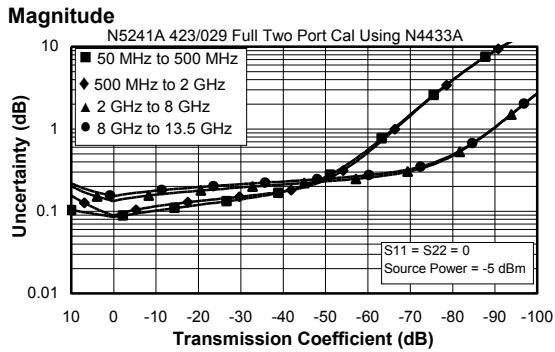

N5242 Opt 423 / 029 with N4433A (S21)

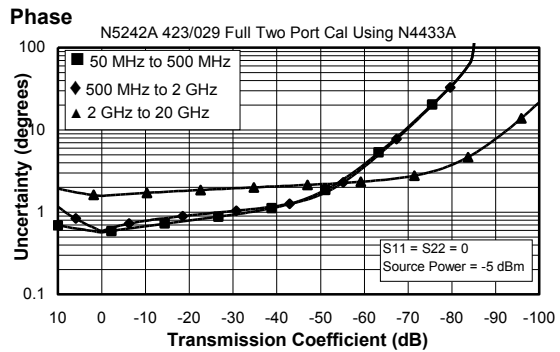
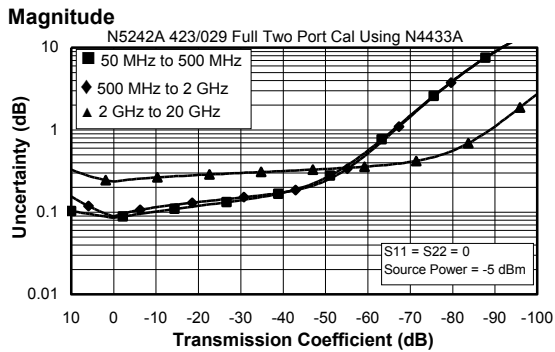

Specifications: N5241A and N5242A Option 029 (continued)

Transmission Uncertainty (S12)

The following charts were generated for Opt 423 / 029 although they are applicable for any option including Opt 029.

N5241 Opt 423 / 029 with N4433A (S12)

Magnitude

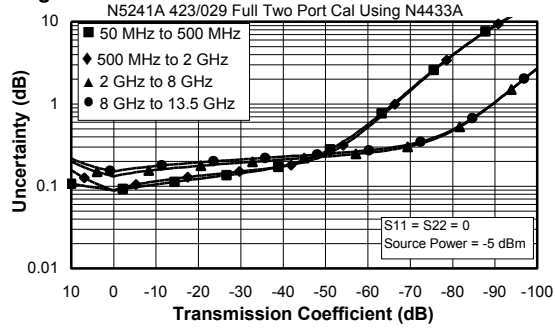

Phase

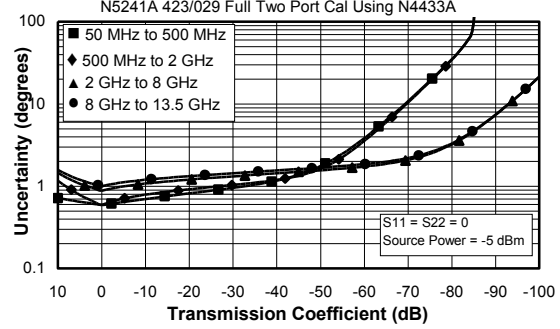

N5242 Opt 423 / 029 with N4433A (S12)

Magnitude

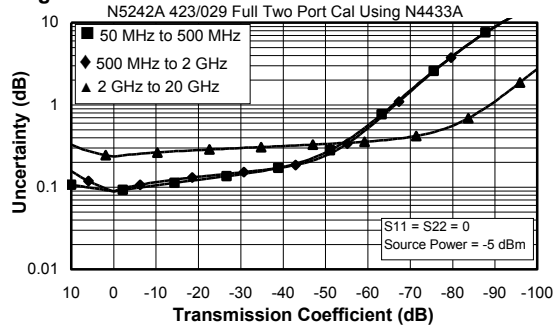

Phase

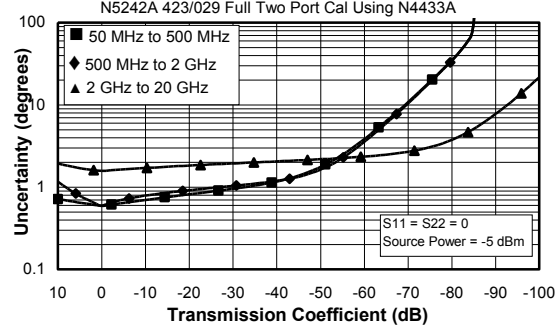

Specifications: N5241A and N5242A Option 029 (continued)

Reflection Uncertainty

The following charts were generated for Opt 423 / 029 although they are applicable for any option including Opt 029.

N5241 Opt 423 / 029 with N4433A

Magnitude

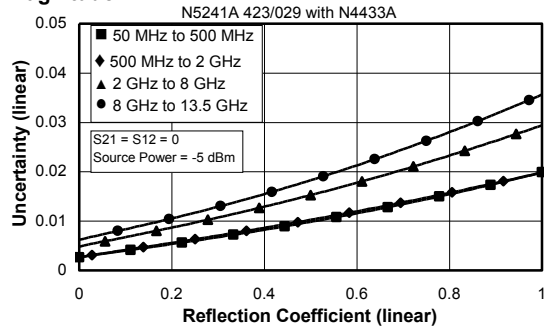

Phase

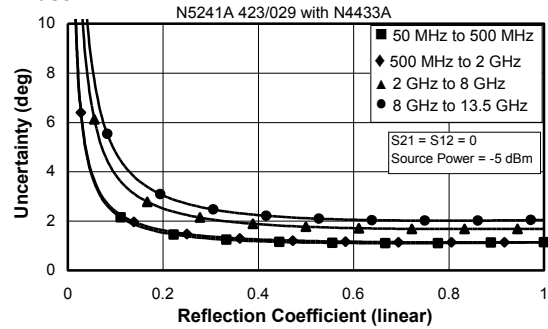

N5242 Opt 423 / 029 with N4433A

Magnitude

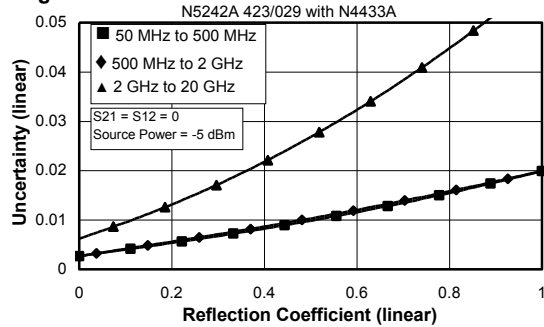

Phase

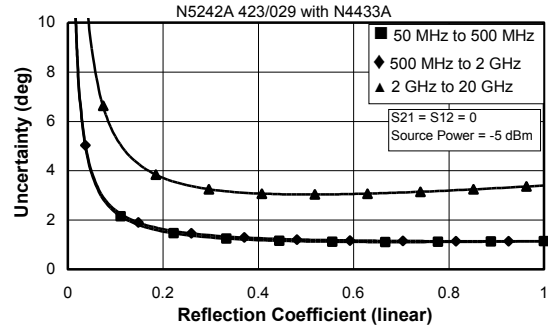

Table 46. N4691B 2- Port Electronic Calibration Module**N5241A and N5242A Option 029**

Applies to the N5241A and N5242A analyzer with Option 029, an N4691B (3.5mm) electronic calibration module, an 85131F flexible test port cable set, and a full 2-port calibration. S-parameter measurements were made with the analyzer in the noise figure configuration. Environmental temperature $23^{\circ} \pm 3^{\circ} \text{C}$, with $< 1^{\circ} \text{C}$ deviation from calibration temperature.

Description	Specification (dB)				
	50 MHz to 500 MHz	500 MHz to 2 GHz	2 GHz to 13.5 GHz	13.5 GHz to 20 GHz	20 GHz to 26.5 GHz
Directivity	46	56	48	48	44
Source Match	41	47	44	44	40
Load Match	40	46	41	41	38
Reflection Tracking ¹	± 0.050 $+0.010/^{\circ}\text{C}$	± 0.020 $+0.010/^{\circ}\text{C}$	± 0.040 $+0.020/^{\circ}\text{C}$	± 0.040 $+0.020/^{\circ}\text{C}$	± 0.050 $+0.030/^{\circ}\text{C}$
S ₂₁ Transmission Tracking ¹	± 0.060 $+0.010/^{\circ}\text{C}$	± 0.025 $+0.010/^{\circ}\text{C}$	± 0.058 $+0.020/^{\circ}\text{C}$	± 0.058 $+0.020/^{\circ}\text{C}$	± 0.079 $+0.030/^{\circ}\text{C}$
S ₁₂ Transmission Tracking ¹	± 0.068 $+0.010/^{\circ}\text{C}$	± 0.026 $+0.010/^{\circ}\text{C}$	± 0.059 $+0.020/^{\circ}\text{C}$	± 0.059 $+0.020/^{\circ}\text{C}$	± 0.119 $+0.030/^{\circ}\text{C}$

¹ Temperature deviation is a characteristic value.

Specifications: N5241A and N5242A Option 029 (continued)

Transmission Uncertainty (S21)

The following charts were generated for Opt 423 / 029 although they are applicable for any option including Opt 029.

N5241 Opt 423 / 029 with N4691B (S21)

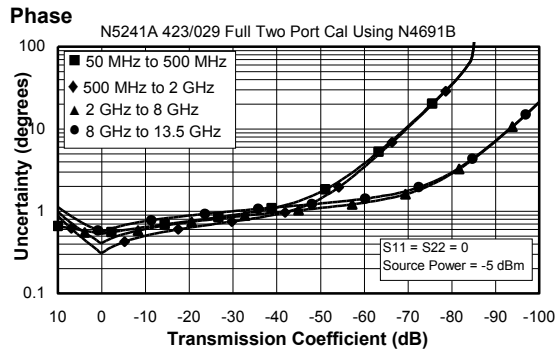
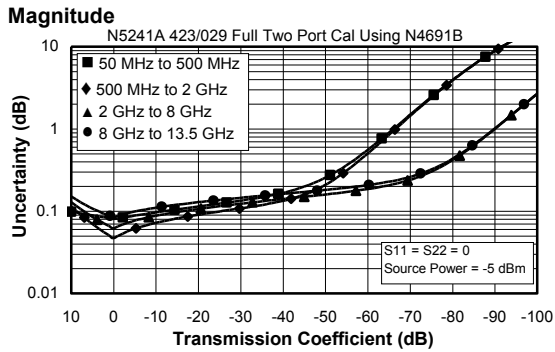

N5242 Opt 423 / 029 with N4691B (S21)

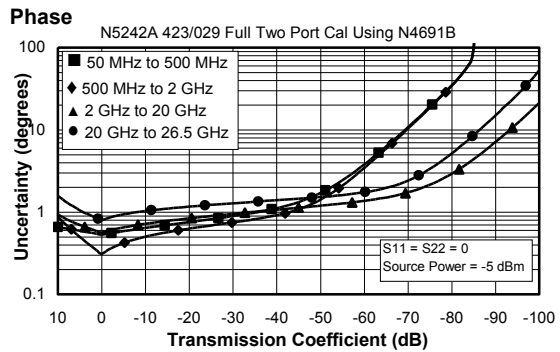
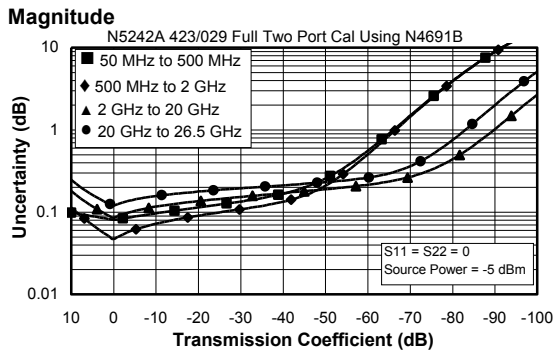

Specifications: N5241A and N5242A Option 029 (continued)

Transmission Uncertainty (S12)

The following charts were generated for Opt 423 / 029 although they are applicable for any option including Opt 029.

N5241 Opt 423 / 029 with N4691B (S12)

Magnitude

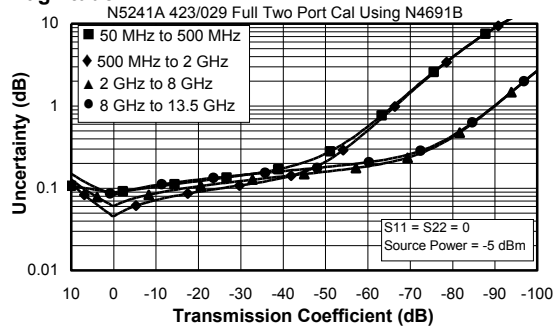

Phase

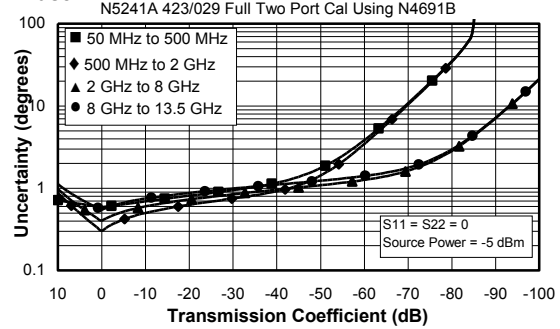

N5242 Opt 423 / 029 with N4691B (S12)

Magnitude

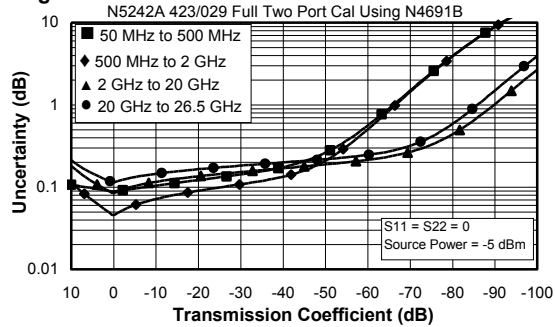

Phase

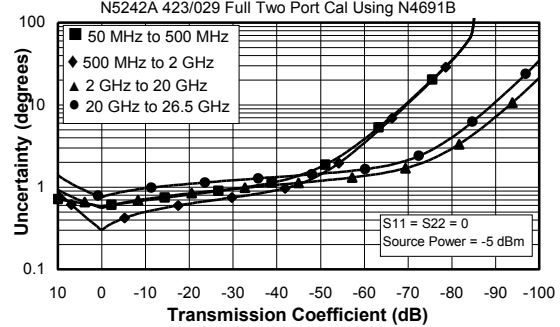

Specifications: N5241A and N5242A Option 029 (continued)

Reflection Uncertainty

The following charts were generated for Opt 423 / 029 although they are applicable for any option including Opt 029.

N5241 Opt 423 / 029 with N4691B

Magnitude

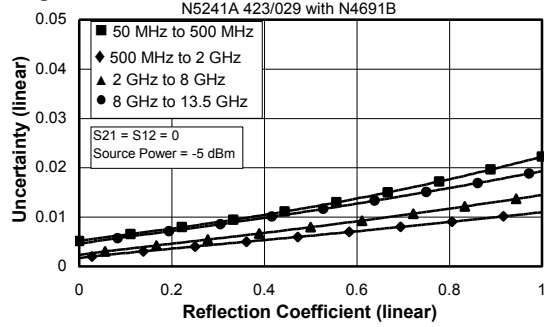

Phase

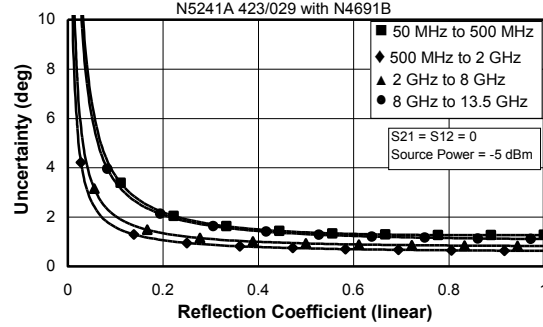

N5242 Opt 423 / 029 with N4691B

Magnitude

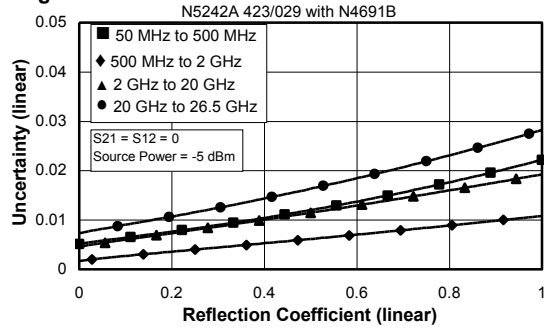

Phase

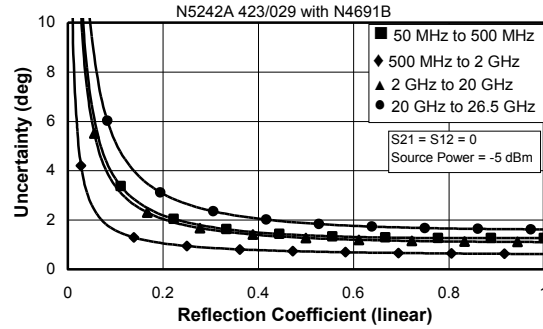

This document does not present specifications for the 85052C or 85052D Calibration Kit. Please download our free Uncertainty Calculator from http://www.agilent.com/find/na_calculator to generate the data and curves for the 85052C or the 85052D Calibration Kit.

Uncorrected System Performance, N5241A and N5242A Option 029

Noise Error Terms: N5241A and N5242A Option 029

Table 47. Noise State Directivity, Port 1 and Port 2¹ (dB)

Frequency	Specification	Typical
10 MHz to 50 MHz	-16	-22
50 MHz to 500 MHz	-24	-28
500 MHz to 3.2 GHz	-24	-32
3.2 GHz to 10 GHz	-23	-25
10 GHz to 13.5 GHz	-16	-20
13.5 GHz to 16 GHz	-16	-20
16 GHz to 20 GHz	-15	-20
20 GHz to 24 GHz	-15	-20
24 GHz to 26.5 GHz	-15	-20

¹Analyzer test set switches are set in accordance with the [Figure 22 block diagram](#), but with a jumper replacing the ECal module.

Table 48. Noise State Load Match, Port 1¹ (dB)

Frequency	Specification	Typical
10 MHz to 50 MHz	-11	-18
50 MHz to 500 MHz	-17	-24
500 MHz to 3.2 GHz	-15	-19
3.2 GHz to 10 GHz	-10	-15
10 GHz to 13.5 GHz	-9	-15
13.5 GHz to 16 GHz	-9	-15
16 GHz to 20 GHz	-8	-13
20 GHz to 24 GHz	-7	-13
24 GHz to 26.5 GHz	-7	-11

¹Analyzer test set switches are set in accordance with the [Figure 22 block diagram](#), but with a jumper replacing the ECal module.

Table 49. Noise State Load Match, Port 2¹ (dB)

Frequency	Specification	Typical
10 MHz to 50 MHz	-9	-12
50 MHz to 500 MHz	-13	-15
500 MHz to 3.2 GHz	-9	-12
3.2 GHz to 10 GHz	-5.5	-7.5
10 GHz to 13.5 GHz	-5.5	-7.5
13.5 GHz to 16 GHz	-5.5	-7.5
16 GHz to 20 GHz	-5.5	-7.5
20 GHz to 24 GHz	-5.5	-7.5
24 GHz to 26.5 GHz	-5.5	-7.5

¹Analyzer test set switches are set in accordance with the [Figure 22 block diagram](#), but with a jumper replacing the ECal module.

Table 50. Noise State Reflection Tracking (S_{11} and S_{22}), Min/Max (dB)

Frequency	Specification	Typical
10 MHz to 50 MHz	--	+/-1.5
50 MHz to 500 MHz	--	+/-1.5
500 MHz to 3.2 GHz	--	+/-1.5
3.2 GHz to 10 GHz	--	+/-1.5
10 GHz to 13.5 GHz	--	+/-1.5
13.5 GHz to 16 GHz	--	+/-1.5
16 GHz to 20 GHz	--	+/-1.5
20 GHz to 24 GHz	--	+/-1.5
24 GHz to 26.5 GHz	--	+/-1.5

Table 51. Noise State Transmission Tracking, Min/Max (dB)

Frequency	Specification	Typical
10 MHz to 50 MHz	--	+/-1.5
50 MHz to 500 MHz	--	+/-1.5
500 MHz to 3.2 GHz	--	+/-1.5
3.2 GHz to 10 GHz	--	+/-1.5
10 GHz to 13.5 GHz	--	+/-1.5
13.5 GHz to 16 GHz	--	+/-1.5
16 GHz to 20 GHz	--	+/-1.5
20 GHz to 24 GHz	--	+/-1.5
24 GHz to 26.5 GHz	--	+/-1.5

Table 52. Noise State Source Match, Port 1¹ (dB)

Frequency	Specification	Typical
10 MHz to 50 MHz	-9	-13
50 MHz to 500 MHz	-18	-28
500 MHz to 3.2 GHz	-17	-22
3.2 GHz to 10 GHz	-12	-18
10 GHz to 13.5 GHz	-11	-16
13.5 GHz to 16 GHz	-11	-16
16 GHz to 20 GHz	-9	-13
20 GHz to 24 GHz	-8	-13
24 GHz to 26.5 GHz	-7	-12

¹Analyzer test set switches are set in accordance with the [Figure 22 block diagram](#), but with a jumper replacing the ECal module.

Table 53. Noise State Source Match, Port 2¹ (dB)

Frequency	Specification	Typical
10 MHz to 50 MHz	-9	-12
50 MHz to 500 MHz	-13	-15
500 MHz to 3.2 GHz	-9	-12
3.2 GHz to 10 GHz	-6	-7
10 GHz to 13.5 GHz	-6	-8
13.5 GHz to 16 GHz	-6	-8
16 GHz to 20 GHz	-7	-9
20 GHz to 24 GHz	-6	-9
24 GHz to 26.5 GHz	-6	-9

¹Analyzer test set switches are set in accordance with the [Figure 22 block diagram](#), but with a jumper replacing the ECal module.

Test Port Input: Option 029

Table 54. Receiver Noise Figure, Port 2 (dB)

Frequency	Specification	Typical
800 kHz, 2 MHz, 4 MHz, 8 MHz BW, High Gain Setting¹		
10 MHz to 200 MHz	9.0	--
200 MHz to 2 GHz	12.0	--
2 GHz to 13.5 GHz	14.5	--
13.5 GHz to 20 GHz	14.5	--
20 GHz to 26.5 GHz	17.0	--
24 MHz BW, High Gain Setting¹		
20 MHz to 200 MHz	9.0	--
200 MHz to 2 GHz	12.0	--
2 GHz to 13.5 GHz	14.5	--
13.5 GHz to 20 GHz	14.5	--
20 GHz to 26.5 GHz	18.5	--

¹Using Option 029 noise receivers.

Table 55. Noise Jitter^{1,2} (dB)

Frequency	Specification	Typical
4 MHz BW, Low Gain Setting		
10 MHz to 15 MHz	0.30	0.15
15 MHz to 3 GHz	0.10	0.07
3 GHz to 13.5 GHz	0.11	0.07
13.5 GHz to 26.5 GHz	0.11	0.07
4 MHz BW, Medium Gain Setting		
10 MHz to 15 MHz	0.30	0.15
15 MHz to 3 GHz	0.10	0.07
3 GHz to 13.5 GHz	0.10	0.07
13.5 GHz to 26.5 GHz	0.10	0.07
4 MHz BW, High Gain Setting		
10 MHz to 15 MHz	0.10	0.07
15 MHz to 3 GHz	0.10	0.07
3 GHz to 13.5 GHz	0.10	0.07
13.5 GHz to 26.5 GHz	0.10	0.07

¹ 201 points, 1 noise average

² May typically be degraded at frequencies below 500 MHz due to spurious noise receiver residuals.

Table 56. Noise Receiver Linearity (dB)

Power Range	Specification	Typical
4 MHz BW, Low Gain Setting		
-34 dBm to -64 dBm	+/-0.05 dB	--
-64 dBm to -70 dBm	+/-0.10 dB	--
4 MHz BW, Medium Gain Setting		
-48 dBm to -76 dBm	+/-0.05 dB	--
-76 dBm to -86 dBm	+/-0.10 dB	--
4 MHz BW, High Gain Setting		
-58 dBm to -84 dBm	+/-0.05 dB	--
-84 dBm to -92 dBm	+/-0.10 dB	--

Table 57. Noise Receiver Input Range

Power Range	Specification		
	High Gain Setting	Medium Gain Setting	Low Gain Setting
500 MHz to 3 GHz			
Max DUT NF + Gain (dB)	32 dB	44 dB	55 dB
Max Input Power (dBm) for <0.1 dB Compression ¹	<=-57 dBm	<=-45 dBm	<=-34 dBm
Max Operating Input Power (dBm)	-37 dBm Typical	-33 dBm Typical	-26 dBm Typical
Limit BW for full NF + Gain	400 MHz	400 MHz	400 MHz
3 GHz to 13.5 GHz			
Max DUT NF + Gain (dB)	46 dB	57 dB	68 dB
Max Input Power (dBm) for <0.1 dB Compression ¹	<=-43 dBm	<=-32 dBm	<=-21 dBm
Max Operating Input Power (dBm) Typical	-23 dBm	-20 dBm	-13 dBm
Limit BW for full NF + Gain	400 MHz	400 MHz	400 MHz
13.5 GHz to 26.5 GHz			
Max DUT NF + Gain (dB)	46 dB	57 dB	68 dB
Max Input Power (dBm) for <0.1 dB Compression ¹	<=-43 dBm	<=-32 dBm	<=-21 dBm
Max Operating Input Power (dBm) Typical	-23 dBm	-20 dBm	-13 dBm
Limit BW for full NF + Gain	400 MHz	400 MHz	400 MHz

¹ Derived from 0.25 dB CW compression specification and -5 dB offset, derived from exponential model for device compression. Referenced to test port 2.

Test Port Output: Option 029

Table 58. Max Leveled Power, Port 1 Filtered Mode

Option 219/029, 419/029 (dBm)

Frequency	Specification	Typical
10 MHz to 50 MHz	7	9
50 MHz to 500 MHz	9	10
500 MHz to 3.2 GHz	9	10
3.2 GHz to 10 GHz	12	17
10 GHz to 13.5 GHz	12	15
13.5 GHz to 16 GHz	12	15
16 GHz to 20 GHz	10	13
20 GHz to 24 GHz	8	12
24 GHz to 26.5 GHz	3	8

Table 59. Max Leveled Power, Port 1 High Power Mode

Option 219/029, 419/029 (dBm)

Frequency	Specification	Typical
10 MHz to 50 MHz	12	18
50 MHz to 500 MHz	12	19
500 MHz to 3.2 GHz	9	12
3.2 GHz to 10 GHz	12	17
10 GHz to 13.5 GHz	12	15
13.5 GHz to 16 GHz	12	15
16 GHz to 20 GHz	10	13
20 GHz to 24 GHz	8	12
24 GHz to 26.5 GHz	3	8

Table 60. Max Leveled Power, Port 1 Filtered Mode**Option 224/029, 423/029 (dBm)**

Frequency	Specification	Typical
10 MHz to 50 MHz	6	8
50 MHz to 500 MHz	8	11
500 MHz to 3.2 GHz	8	11
3.2 GHz to 10 GHz	13	19
10 GHz to 13.5 GHz	12	15
13.5 GHz to 16 GHz	12	15
16 GHz to 20 GHz	10	13
20 GHz to 24 GHz	6	11
24 GHz to 26.5 GHz	0	8

Table 61. Max Leveled Power, Port 1 High Power Mode**Option 224/029, 423/029 (dBm)**

Frequency	Specification	Typical
10 MHz to 50 MHz	12	18
50 MHz to 500 MHz	13	20
500 MHz to 3.2 GHz	10	13
3.2 GHz to 10 GHz	13	19
10 GHz to 13.5 GHz	12	15
13.5 GHz to 16 GHz	12	15
16 GHz to 20 GHz	10	13
20 GHz to 24 GHz	6	11
24 GHz to 26.5 GHz	0	8

Table 62. Max Leveled Power, Port 1 Source 1, Combine Mode, Filtered Mode**Option 224/029, 423/029 (dBm)**

Frequency	Specification	Typical
10 MHz to 50 MHz	--	6
50 MHz to 500 MHz	--	9
500 MHz to 3.2 GHz	--	9
3.2 GHz to 10 GHz	--	15
10 GHz to 13.5 GHz	--	11
13.5 GHz to 16 GHz	--	11
16 GHz to 20 GHz	--	8
20 GHz to 24 GHz	--	5
24 GHz to 26.5 GHz	--	0

Table 63. Max Leveled Power, Port 1 Source 1, Combine Mode, High Power Mode**Option 224/029, 423/029 (dBm)**

Frequency	Specification	Typical
10 MHz to 50 MHz	--	16
50 MHz to 500 MHz	--	17
500 MHz to 3.2 GHz	--	10
3.2 GHz to 10 GHz	--	15
10 GHz to 13.5 GHz	--	11
13.5 GHz to 16 GHz	--	11
16 GHz to 20 GHz	--	8
20 GHz to 24 GHz	--	5
24 GHz to 26.5 GHz	--	0

Table 64. Max Leveled Power, Port 1 Source 2, Combine Mode, Filtered Mode**Option 224/029, 423/029 (dBm)**

Frequency	Specification	Typical
10 MHz to 50 MHz	--	-8
50 MHz to 500 MHz	--	-5
500 MHz to 3.2 GHz	--	-5
3.2 GHz to 10 GHz	--	2
10 GHz to 13.5 GHz	--	-2
13.5 GHz to 16 GHz	--	-2
16 GHz to 20 GHz	--	-4
20 GHz to 24 GHz	--	-7
24 GHz to 26.5 GHz	--	-11

Table 65. Max Leveled Power, Port 1 Source 2, Combine Mode, High Power Mode**Option 224/029, 423/029 (dBm)**

Frequency	Specification	Typical
10 MHz to 50 MHz	--	2
50 MHz to 500 MHz	--	4
500 MHz to 3.2 GHz	--	-4
3.2 GHz to 10 GHz	--	2
10 GHz to 13.5 GHz	--	-2
13.5 GHz to 16 GHz	--	-2
16 GHz to 20 GHz	--	-4
20 GHz to 24 GHz	--	-7
24 GHz to 26.5 GHz	--	-11

Table 66. Max Leveled Power, Port 2**Option 219/029, 419/029 (dBm)**

Frequency	Specification	Typical
10 MHz to 50 MHz	13	17
50 MHz to 500 MHz	13	19
500 MHz to 3.2 GHz	13	18
3.2 GHz to 10 GHz	13	17
10 GHz to 13.5 GHz	9	12
13.5 GHz to 16 GHz	9	12
16 GHz to 20 GHz	5	7
20 GHz to 24 GHz	2	4
24 GHz to 26.5 GHz	-2	3

Table 67. Max Leveled Power, Port 2**Option 224/029, 423/029 (dBm)**

Frequency	Specification	Typical
10 MHz to 50 MHz	13	17
50 MHz to 500 MHz	13	20
500 MHz to 3.2 GHz	12	16
3.2 GHz to 10 GHz	13	17
10 GHz to 13.5 GHz	10	14
13.5 GHz to 16 GHz	10	14
16 GHz to 20 GHz	6	9
20 GHz to 24 GHz	4	8
24 GHz to 26.5 GHz	-2	4

Test Set Block Diagrams

NOTE: For best readability, use a color printer for printing the following graphics.

Figure 15. 2-Port N5241A and N5242A Base Unit (Option 200)

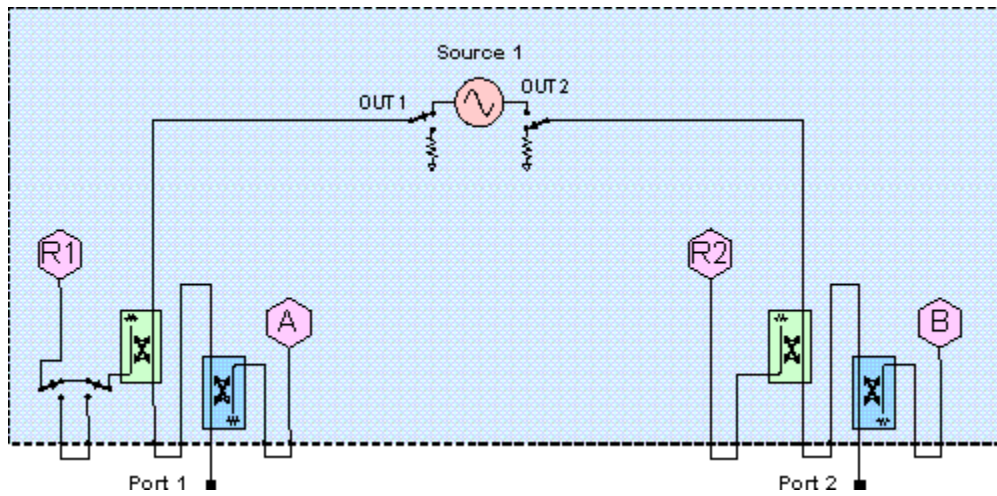

Figure 16. 2-Port N5241A and N5242A (Option 219)

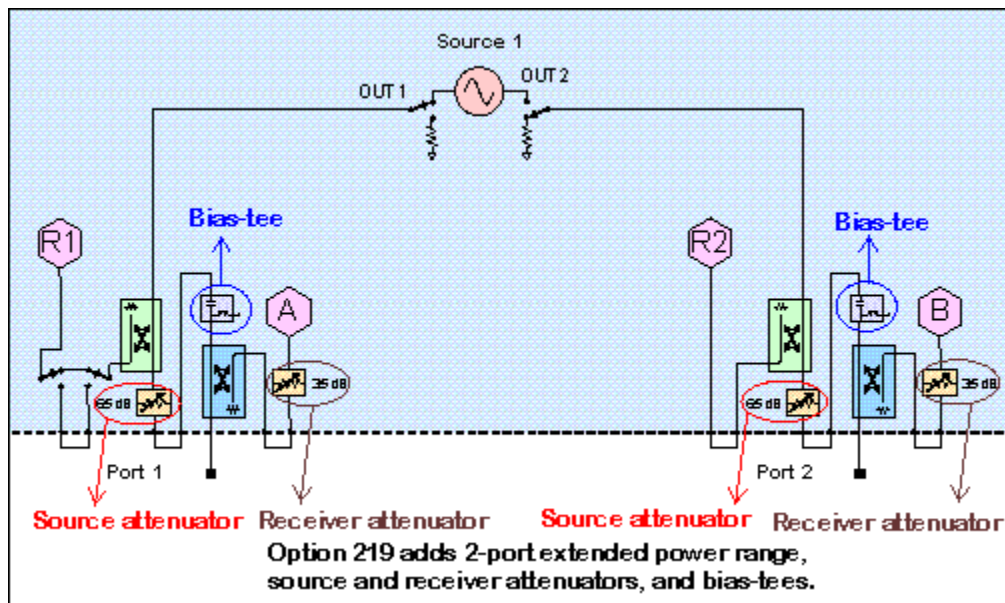

Figure 17. 2-Port N5241A and N5242A (Option 224)

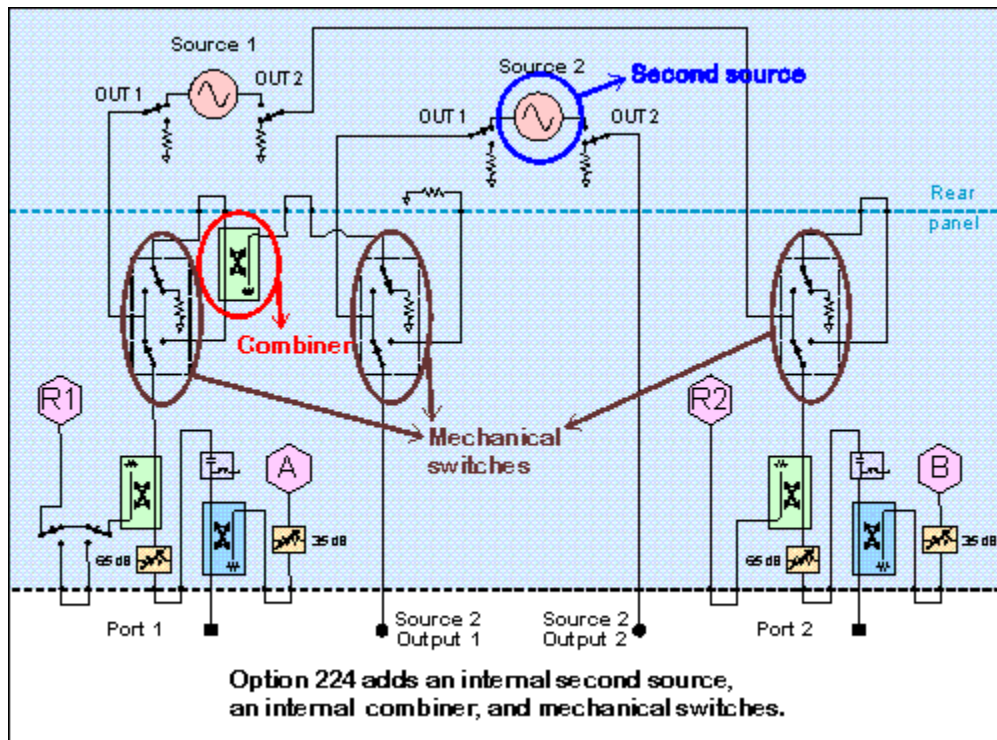

Figure 18. 4-Port N5241A and N5242A Base Unit (Option 400)

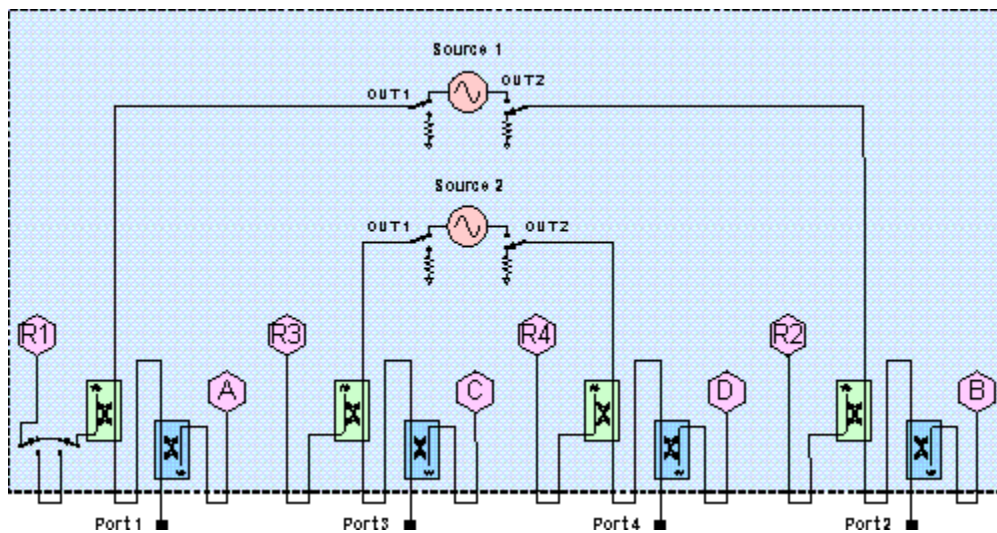

Figure 19. 4-Port N5241A and N5242A (Option 419)

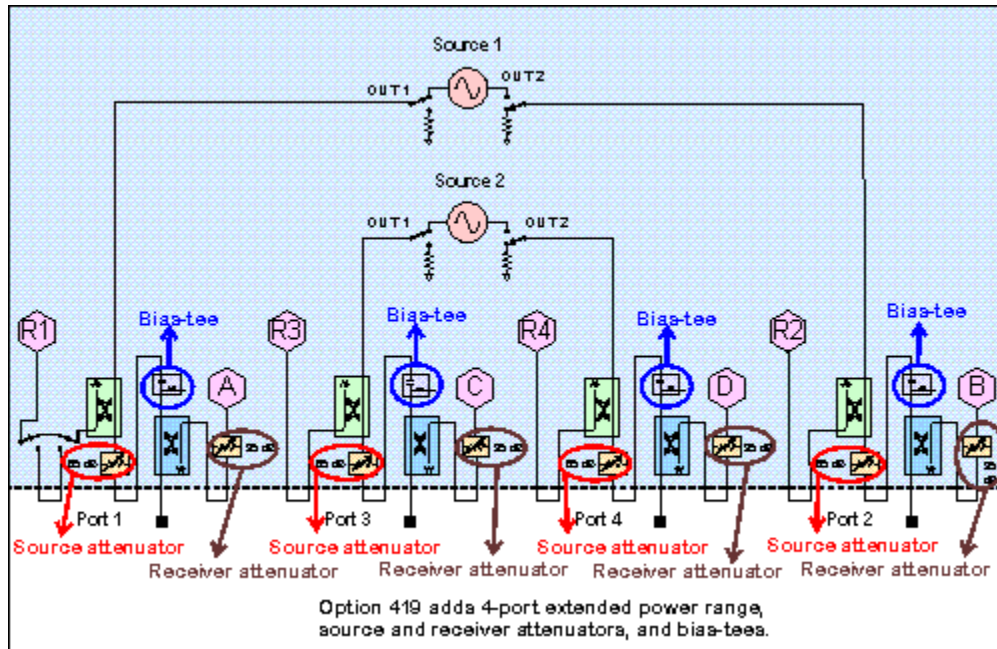
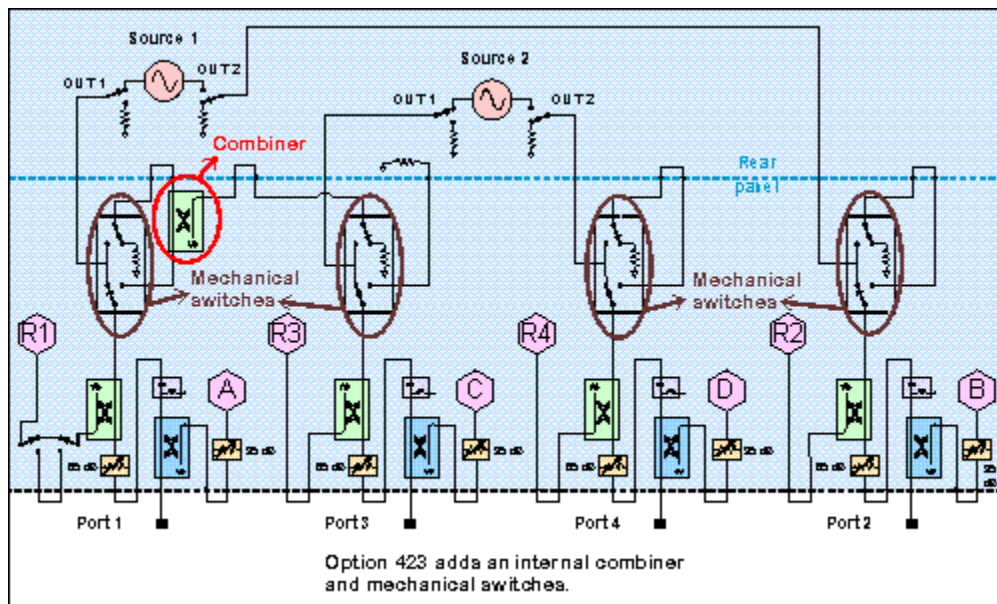

Figure 20. 4-Port N5241A and N5242A (Option 423)



2-Port PNA-X Options 219, 224

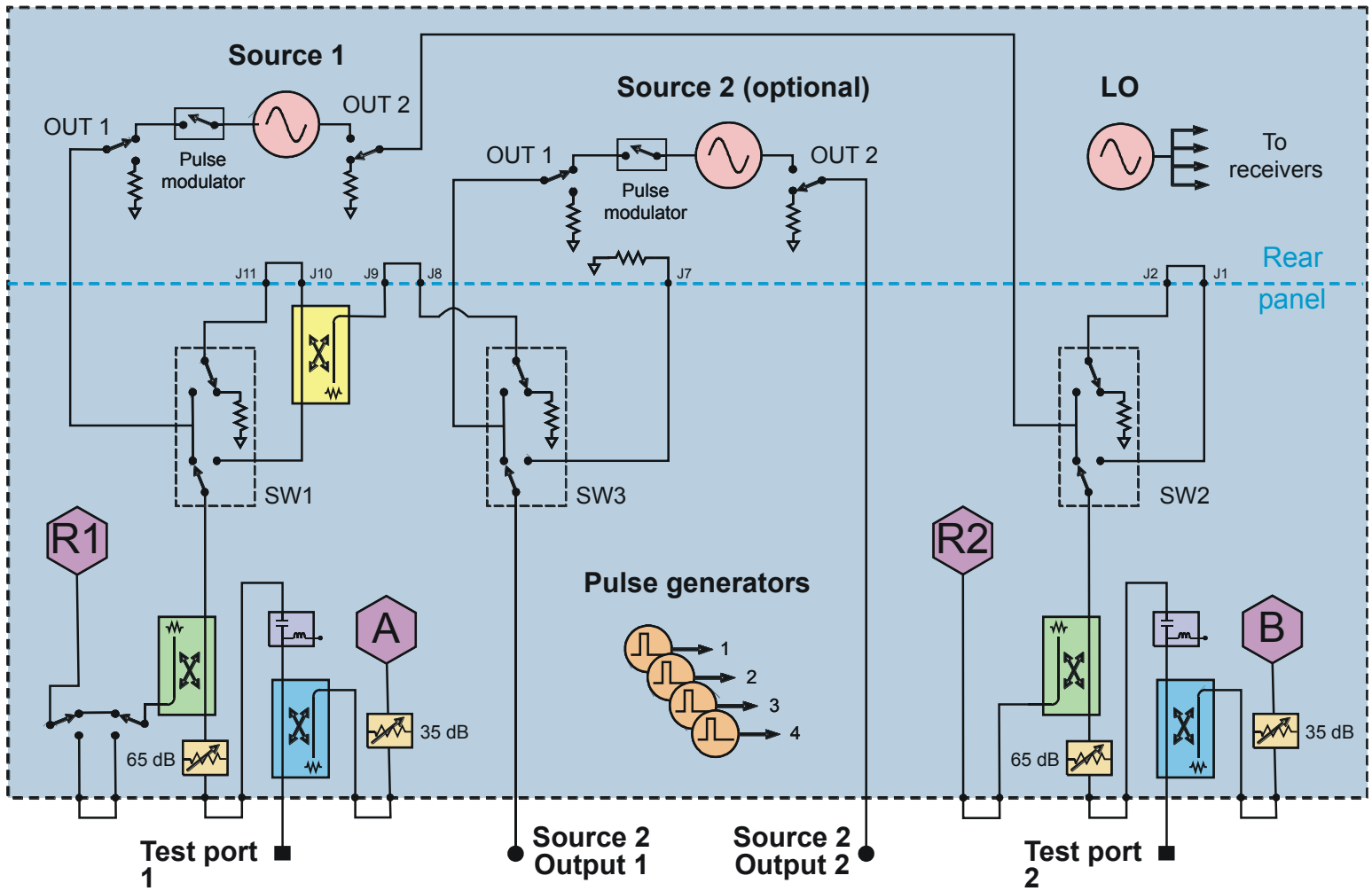

Figure 21. 2-Port N5241A and N5242A (Option 219, 224), Showing J-Designators for Rear Panel Connectors

Figure 22. 4-Port N5241A and N5242A (Option 419, 423), Showing J-Designators for Rear Panel Connectors

4-Port PNA-X Options 419, 423

115

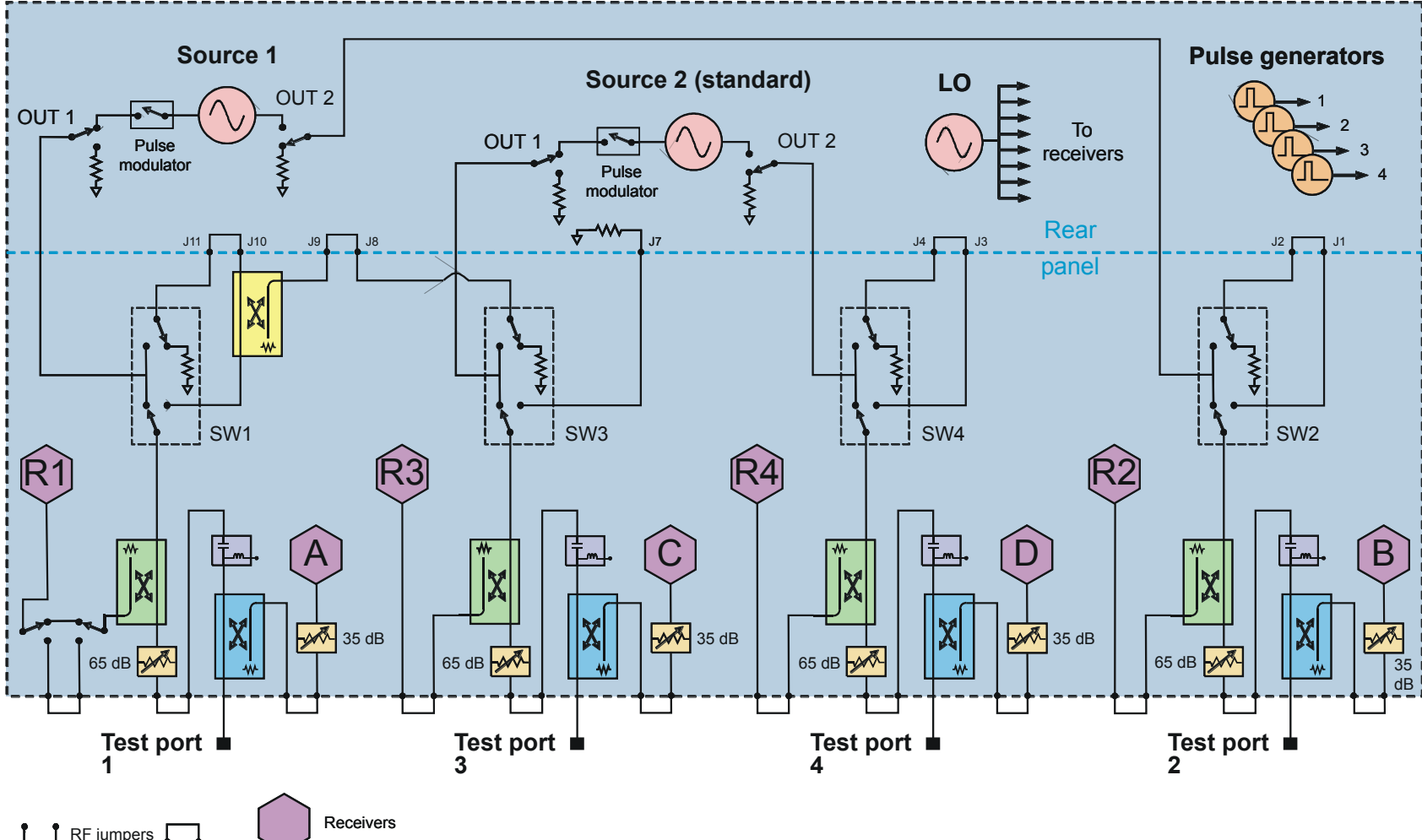

Figure 23. Receiver Block Diagram

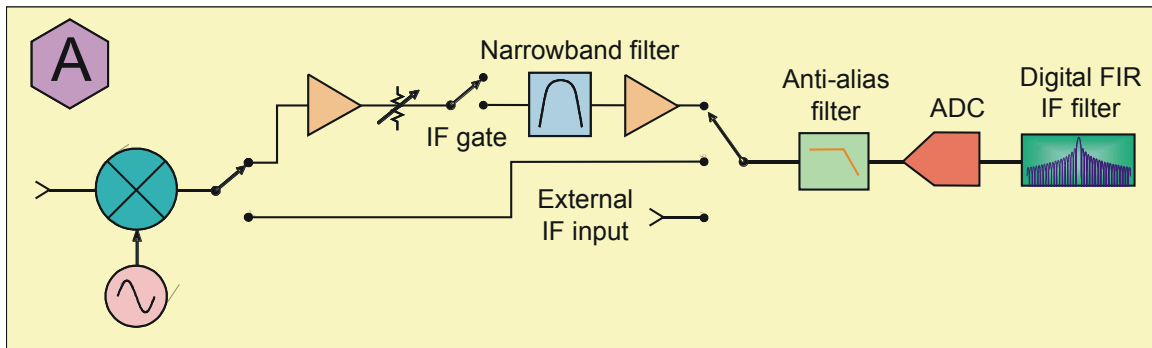
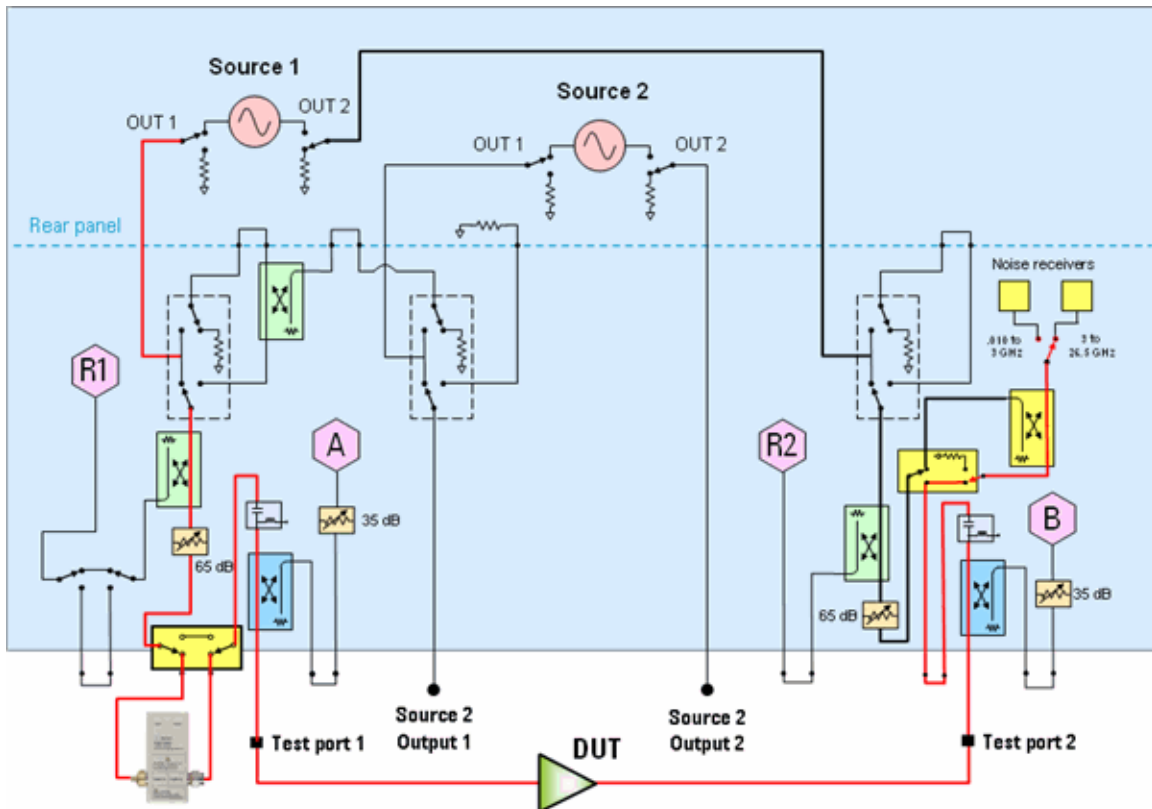

Figure 24. 2-Port N5241A and N5242A with Noise Figure Hardware (shown with Options 200, 219, 224, & 029).

On 4-Port analyzers (Option 419 or 423) with Option 029, ports 1 and 2 are the same as shown here.



- At test port 1 front panel loops, a noise tuner switch connects the noise tuner (ECal module) in series with Source 1, providing several different input impedances.
- At test port 2, a noise tuner switch and a coupler route the RF signal from the DUT output to two noise receivers. The appropriate receiver is automatically selected as required for the frequency being measured.



Agilent Email Updates

www.agilent.com/find/emailupdates

Get the latest information on the products and applications you select.



www.axiestandard.org

AdvancedTCA® Extensions for Instrumentation and Test (AXIe) is an open standard that extends the AdvancedTCA for general purpose and semiconductor test. Agilent is a founding member of the AXIe consortium.



www.lxistandard.org

LAN eXtensions for Instruments puts the power of Ethernet and the Web inside your test systems. Agilent is a founding member of the LXI consortium.



www.pxisa.org

PCI eXtensions for Instrumentation (PXI) modular instrumentation delivers a rugged, PC-based high-performance measurement and automation system.

Agilent Channel Partners

www.agilent.com/find/channelpartners

Get the best of both worlds: Agilent's measurement expertise and product breadth, combined with channel partner convenience.



Agilent Advantage Services is committed to your success throughout your equipment's lifetime. To keep you competitive, we continually invest in tools and processes that speed up calibration and repair and reduce your cost of ownership. You can also use Infoline Web Services to manage equipment and services more effectively. By sharing our measurement and service expertise, we help you create the products that change our world.

www.agilent.com/find/advantageservices



www.agilent.com

www.agilent.com/find/pnax

For more information on Agilent Technologies' products, applications or services, please contact your local Agilent office. The complete list is available at:

www.agilent.com/find/contactus

Americas

Canada	(877) 894-4414
Brazil	(11) 4197 3500
Mexico	01800 5064 800
United States	(800) 829-4444

Asia Pacific

Australia	1 800 629 485
China	800 810 0189
Hong Kong	800 938 693
India	1 800 112 929
Japan	0120 (421) 345
Korea	080 769 0800
Malaysia	1 800 888 848
Singapore	1 800 375 8100
Taiwan	0800 047 866
Other AP Countries	(65) 375 8100

Europe & Middle East

Belgium	32 (0) 2 404 93 40
Denmark	45 70 13 15 15
Finland	358 (0) 10 855 2100
France	0825 010 700* *0.125 €/minute
Germany	49 (0) 7031 464 6333
Ireland	1890 924 204
Israel	972-3-9288-504/544
Italy	39 02 92 60 8 484
Netherlands	31 (0) 20 547 2111
Spain	34 (91) 631 3300
Sweden	0200-88 22 55
United Kingdom	44 (0) 118 9276201

For other unlisted countries:

www.agilent.com/find/contactus

Product specifications and descriptions in this document subject to change without notice.

© Agilent Technologies, Inc. 2011
Published in USA, Sept 29, 2011
Supersedes: June 13, 2011
N5242-90007



Agilent Technologies