

Agilent N7788B Optical Component Analyzer

Data Sheet

Introduction

Agilent Technologies pushes the limits of component measurements with the N7788B component analyzer. Its proprietary technology is comparable with the well-known **Jones-Matrix-Eigenanalysis (JME)** which is the standard method for measuring polarization mode dispersion (PMD) or differential group delay (DGD) of optical devices.

For spectral measurements of polarization dependent loss and dispersion, the N7788B is combined with an Agilent swept-wavelength tunable laser, such as the 81600B or 81960A (not included) and the Polarization Navigator software application for single-scan measurements. Compared to the JME, Agilent's powerful **single scan technology** offers a range of advantages:

A complete set of parameters:

- DGD/PMD
- PDL
- Power/loss
- TE/TM-loss
- Jones matrices
- Mueller matrices
- 2nd-order PMD (depolarization + PCD)
- Principal states of polarization (PSPs)



Figure 1. N7788B optical component analyzer

Key Benefits

- **Highest accuracy** in a single sweep: no averaging over multiple sweeps required.
- **High measurement speed:** Complete measurement across C/L-band in less than 10 seconds (no need to wait for many averages).
- **Robustness** against fiber movement/vibration and drift: Fixing fibers with sticky tape on the table or even operation on isolated optical table is not required! The single-scan measurement fully characterizes each wavelength point in 0.3 ms rather than after multiple sweeps over many seconds.
- **No limitation on optical path length** of component.
- The **internal referencing scheme** guarantees reliable and accurate measurements.



Agilent Technologies

Applications

- Fiber characterization: SMF, PMF, DCF.
- Passive component testing: filters, isolators, circulators.
- Dynamic component/module testing: OADM/ROADM.
- Active component testing: EDFAs, SOAs,VOAs.
- Link test: in-channel measurements across amplifiers.

Designed for the manufacturing floor

High throughput

A complete analysis across the C and the L band is performed in less than 10 seconds!

Software drivers

A range of software drivers is available for external control of the system. This allows easy integration in common ERP systems.

Remote control

The N7788B has USB and GPIB interfaces and can be programmed directly or operated manually or automatically via the included Polarization Navigator software.

Report generation

Generating PDF reports is supported. The content including layout is configurable by the user.

Real time power readout

High throughput measurement of non-connectorized components is supported by providing a real time power readout which enables fiber coupling of the new device.

Barcode scanner

Barcode scanning is supported for quick transfer of the DUT serial number.

Agilent N7788B instrument setup and application examples

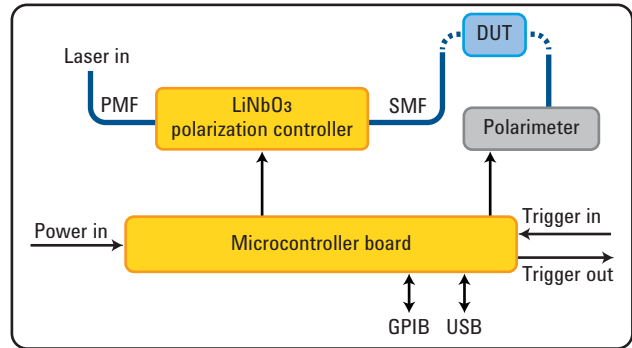

Figure 2. N7788B instrument setup.

The instrument setup is shown in the Figure 2. A LiNbO_3 polarization controller deterministically varies the input polarization to the DUT. As the tunable laser source sweeps over the desired wavelength range, a polarimeter analyzes the output state of polarization while the input polarization is being modified. The result is a highly accurate device characterization with respect to DGD/PDL/loss, etc. Furthermore, the internal optical switch provides continuous self calibration for excellent repeatability.

Resolving TE/TM insertion loss

The TE/TM-function allows accurate determination of the minimum and maximum loss of the DUT at each wavelength and permits determination of the polarization-dependent frequency Pdf of filter passbands.

Due to birefringence, optical filters tend to show different transmission functions depending on the polarization state. As shown in Figure 3, these functions are typically shifted in wavelength depending on the amount of birefringence.

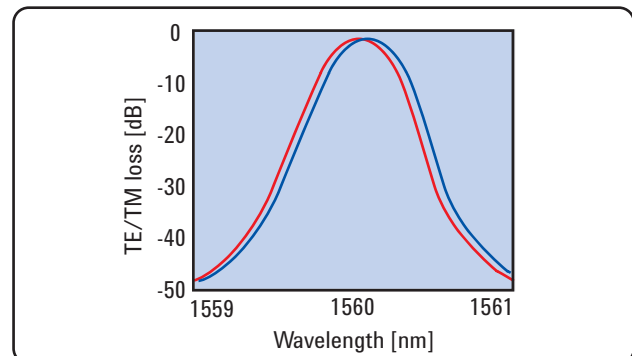

Figure 3. Polarization-dependent wavelength shift (PD-A) of a filter.

The capability of performing quick PMD-measurements makes this measurement system well-suited to collecting long-term PMD data. The PC software allows continuous collection and saving of spectral PMD data. The data can then be visualized as a pseudo-color plot (see Figure 4).

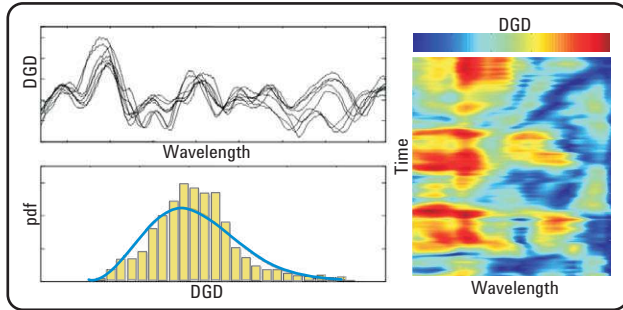

Figure 4. Long term DGD measurements.

The internal reference path allows measurement of insertion loss spectra with excellent accuracy, further minimizing the influence of environmental disturbance to the results.

Configuration for swept-wavelength measurements

The N7788B is configured so that a polarized source like a tunable laser can be input and the polarization-controlled signal is then output to the front panel. It can then be applied to a DUT and the DUT output signal is then returned to the polarization analyzer input of the instrument. Internal switching for automatic referencing is also included. This setup is especially used for measuring wavelength dependent differential group delay, DGD and PMD, together with PDL and IL with a single wavelength sweep. The Polarization Navigator is the user interface for the N778x-series polarization instruments and includes an application engine for this setup. This has now been integrated into the N7700A suite and is free. Installation requires the N7700A Main package and the Polarization Navigator package.

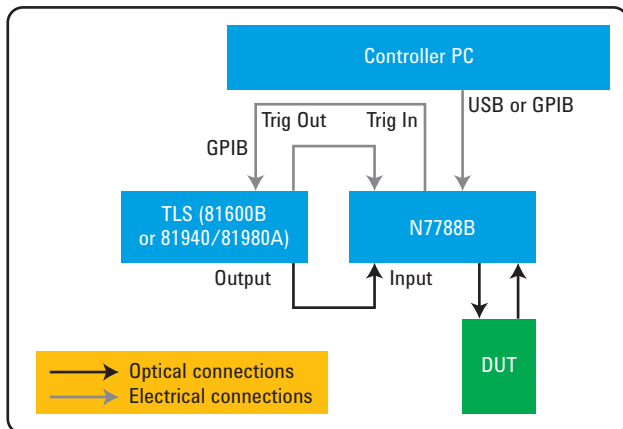

Figure 5. Schematic instrument configuration for swept-wavelength DGD/PMD, PDL and IL measurements using the N7788B.

Due to the excellent spectral resolution, the Agilent N7788B is best suited for intra-channel DGD/PDL characterization.

The all-parameter-JME algorithm allows flexible adjustments of the wavelength resolution without the need to repeat the measurement. This allows the user to easily find the optimum trade-off between PDL/DGD accuracy and wavelength resolution.

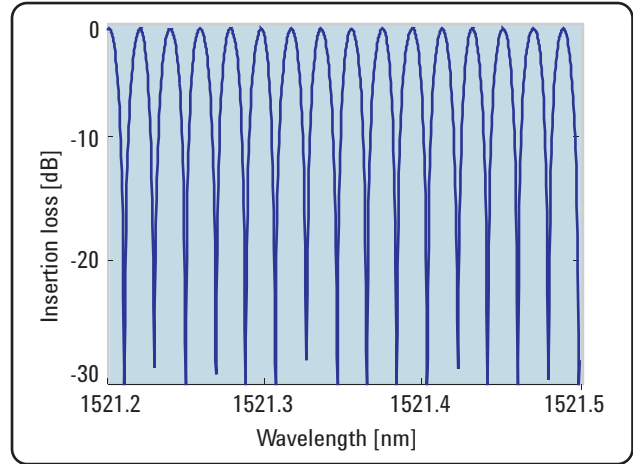

Figure 6. Loss curve of a DPSK demodulator.

Specifications ¹ N7788B Optical Component Analyzer

Wavelength		
Specification wavelength range	1270 nm to 1375 nm (Opt. 300, O-Band)	
	1270 nm to 1375 nm, 1460 nm to 1620 nm (Opt. 400, O/C/L-Band)	
	1460 nm to 1620 nm (Opt. 500, C/L-Band)	
Operating wavelength range ²	1260 nm to 1640 nm	
Differential group delay		
DGD uncertainty ³	Resolution 2.0 nm	$\pm (30 \text{ fs} + 3.0\% * \text{DGD})$
	Resolution 0.1 nm	$\pm (30 \text{ fs} + 3.0\% * \text{DGD})$
DGD measurement range ³	0 ps to 1000 ps	
PMD uncertainty ⁴	$\pm (30 \text{ fs} + 2.0\% * \text{DGD})$	
PMD repeatability (typical)	$\pm 3 \text{ fs}$	
PMD measurement range ⁴	0 ps to 300 ps	
Loss		
PDL uncertainty ⁵	C-Band	$\pm (0.05 \text{ dB} + 4\% * \text{PDL})$
	O-Band	$\pm (0.10 \text{ dB} + 4\% * \text{PDL})$
PDL repeatability (typical)	$\pm 0.005 \text{ dB}$	
Insertion loss uncertainty (typical) ³	C/L-Band	$\pm 0.03 \text{ dB}$
	O-Band	$\pm 0.07 \text{ dB}$
Insertion loss dynamic range (typical) ³	$> 41 \text{ dB}$ (for higher TLS power levels, increase value accordingly)	
Polarization analysis		
SOP uncertainty (typical) ^{6,7}	1.5°	
DOP uncertainty ⁶	$\pm 2.0 \%$	
DOP uncertainty after user calibration (typical) ^{6,8}	$\pm 0.5 \%$	
Maximum sampling rate	1 MHz	
Optical power measurement		
Relative power uncertainty ⁶	C/L-Band: $\pm .03 \text{ dB}$ ($\pm 0.02 \text{ dB}$ typical)	
	O-Band: $\pm 0.07 \text{ dB}$ ($\pm 0.04 \text{ dB}$ typical)	
Input power range	-50 dBm to +7 dBm	
Maximum safe optical input power	+12 dBm	

1. Ambient temperature change max $\pm 0.5 \text{ }^\circ\text{C}$ since normalization. Valid for 81600B Tunable Laser Source Family. TLS power set to -6 dBm. Sweep over specification wavelength range. Specification does not include instability in test device. Specified loss ranges include loss of test device and any additional switches or connections in the optical path. Specification valid on day of calibration.
2. SOP/DOP measurements are only possible outside the specification wavelength range if the user performs a manual calibration.
3. DUT properties: Insertion loss $< 30 \text{ dB}$, PDL $< 1 \text{ dB}$, DGD $< 150 \text{ ps}$. Specification is typical for DGD $> 150 \text{ ps}$.
4. DUT properties: Insertion loss $< 41 \text{ dB}$, PDL $< 3 \text{ dB}$, PMD $< 50 \text{ ps}$. Applies for highly mode-coupled devices such as single mode fibers. Specification applies for PMD being averaged DGD over a wavelength span of 100 nm. Specification is typical for PMD $> 50 \text{ ps}$.
5. DUT properties: Insertion loss $< 25 \text{ dB}$, PDL $< 6 \text{ dB}$. Note: DUT connectors are considered as being part of the DUT. Thus, angled connectors will add to the device PDL.
6. Input power $> -30 \text{ dBm}$
7. DOP $> 95\%$
8. User calibration requires a source with 100% DOP and is valid for a fixed wavelength.

Specifications ¹ N7788B Optical Component Analyzer (continued)

Polarization control		
SOP switching time	< 10 μ s	
PDL (typical)	C/L-Band	< 0.2 dB
	O-Band	< 0.5 dB
Insertion loss	< 3.5 dB (< 3 dB, typical)	
Maximum safe input power	+20 dBm	
Ordering instructions		
Optical connector options for laser input port		
N7788B-021	Straight contact connector	
N7788B-022	Angled contact connector	
Optical connector options for DUT ports		
N7788B-031	Straight contact connector	
N7788B-032	Angled contact connector	
Wavelength options		
N7788B-300	1270 to 1375 nm	
N7788B-400	1270 to 1375 nm and 1460 to 1620 nm	
N7788B-500	1460 to 1620 nm	
Connector interface		
The N7788B should usually be ordered with three 81000xl connector interfaces, depending on desired connector type (not included).		
Accessories		
5063-9240	Rack mount kit for 1 unit with filler panel	
5063-9212 + 5061-9694	Rack mount parts for 2 units side-by-side	
Warranty		
All systems have 1 year warranty		
R-51B-001-3C	1 year Return-to-Agilent warranty extended to 3 years	
R-51B-001-5C	1 year Return-to-Agilent warranty extended to 5 years	
Calibration		
R-50C-011-3	Agilent calibration upfront support plan 3 year coverage	
R-50C-011-5	Agilent calibration upfront support plan 5 year coverage	
General characteristics		
Dimensions (D x W x H)	380 mm x 213 mm x 88 mm (excluding front and back rubber cushions and handle)	
Weight	Approx. 4 kg	
Recommended recalibration period	24 months	
Operating temperature	+5 °C to +40 °C	
Operating humidity	0% to 80%, non-condensing	
Altitude	The maximum operating altitude is 2000 m.	
Pollution protection	Pollution degree 2.	
Warm-up time	20 minutes	
Interfaces	The instruments can be controlled via USB or GPIB interfaces	
Power consumption	Line power: AC 100 to 240 V \pm 10%, 50/60 Hz, 60 VA max.	

 **Agilent Email Updates**

www.agilent.com/find/emailupdates

Get the latest information on the products and applications you select.

Agilent Channel Partners

www.agilent.com/find/channelpartners

Get the best of both worlds: Agilent's measurement expertise and product breadth, combined with channel partner convenience.



Agilent Advantage Services is committed to your success throughout your equipment's lifetime. To keep you competitive, we continually invest in tools and processes that speed up calibration and repair and reduce your cost of ownership. You can also use Infoline Web Services to manage equipment and services more effectively. By sharing our measurement and service expertise, we help you create the products that change our world.

www.agilent.com/find/advantageservices



For more information on Agilent Technologies' products, applications or services, please contact your local Agilent office. The complete list is available at:

www.agilent.com/find/contactus

Americas

Canada	(877) 894 4414
Brazil	(11) 4197 3500
Mexico	01800 5064 800
United States	(800) 829 4444

Asia Pacific

Australia	1 800 629 485
China	800 810 0189
Hong Kong	800 938 693
India	1 800 112 929
Japan	0120 (421) 345
Korea	080 769 0800
Malaysia	1 800 888 848
Singapore	1 800 375 8100
Taiwan	0800 047 866
Other AP Countries	(65) 375 8100

Europe & Middle East

Belgium	32 (0) 2 404 93 40
Denmark	45 70 13 15 15
Finland	358 (0) 10 855 2100
France	0825 010 700*
	*0.125 €/minute
Germany	49 (0) 7031 464 6333
Ireland	1890 924 204
Israel	972-3-9288-504/544
Italy	39 02 92 60 8484
Netherlands	31 (0) 20 547 2111
Spain	34 (91) 631 3300
Sweden	0200-88 22 55
United Kingdom	44 (0) 131 452 0200

For other unlisted countries:

www.agilent.com/find/contactus

Revised: June 8, 2011

Product specifications and descriptions in this document subject to change without notice.

© Agilent Technologies, Inc. 2011
Published in USA, July 26, 2011
5989-8116EN

