



Agilent N1810/1/2 Coaxial Switches

High Performance Electromechanical Switches for Microwave and RF Manufacturing Test Systems

Technical Overview

Key Features

- **High repeatability:** < 0.03 dB guaranteed up to 40 GHz and <0.08 at 67 GHz up to 5 million cycles
- **High isolation:** > 120 dB at 4 GHz and >70 dB at 67 GHz
- **Low SWR:** < 1.10 at 4 GHz and <1.90 at 67 GHz
- **Low-insertion loss:** < 0.27 dB at 4 GHz and < 1.12 at 67 GHz
- **Long life:** > Guaranteed 5 million cycles , 10 million cycles typical



Key Applications

- Radar and satellite testing
- Wireless W-HDMI device testing
- Microwave backhaul applications

- DC to 4 GHz
- DC to 20 GHz
- DC to 26.5 GHz
- DC to 40 GHz
- DC to 50 GHz
- DC to 67 GHz

In today's fast moving technical industries, test engineers need components they can count on. Agilent now offers a new line of latching coaxial switches that combine legendary reliability with the widest range of performance options available today.

Reduce downtime

Agilent Technologies is the world leader in innovating and developing microwave accessories for communications and aerospace applications. Our innovative design and strict adherence to quality process control ensure that each switch is guaranteed to perform within warranted specifications for its entire lifetime. With fewer breakdowns and less need to recalibrate, your test system moves quicker with less downtime, creating more throughput and revenue.

Raise your standards

All Agilent switches offer excellent repeatability and long life — up to five times the lifecycles of the competition. Add to this aggressive specs for isolation, SWR, and insertion loss,

and you have a switch that impresses even the most demanding engineer with its precision and durability.

Increase flexibility

For test systems that require extra functionality or increased performance, the N181x family of switches has a solution that fits your need. The options include:

- Reduced SWR
- Increased isolation
- Standard or TTL drive
- 5, 15, 24 volt drive
- Position indicators

Increase productivity

When you buy your switches from Agilent, you notice a difference. Your test platforms run smoother, longer and faster, while yielding more viable and valuable measurements.



Agilent Technologies

Description

N1810UL

Unterminated latching

The Agilent N1810UL is a single-pole double-throw switch available in the frequency range from DC to 67 GHz. In precision measurements and monitoring applications where insertion loss repeatability is crucial, these switches operate in excess of 5 million cycles with better than .03 dB of insertion loss repeatability at 25 °C.

N1810TL

Terminated latching

The Agilent N1810TL is a single-pole double-throw switch available in the frequency range from DC to 67 GHz. The unused port is terminated 50 ohms, making it ideal for applications where port matching is required.

N1811TL

Terminated latching

The N1811TL is a terminated bypass switch available in the frequency range from DC to 67 GHz. The switch's internal load can terminate the device under test when in the bypass mode (up to 1 watt). Because of its compact design, it is ideal for drop-in, drop-out applications.

N1812UL

Unterminated latching

The N1812UL is a versatile, unterminated 5-port switch available in the frequency range from DC to 67 GHz. In transfer switch applications, the fifth port can be terminated externally with a high-power termination. It can also be utilized for signal path reversal or as a calibration port.

Technology

Agilent Technologies switches are designed with a rectangular coaxial structure similar to edge-line. This transmission line structure provides for movement of the edge-line center conductor between two fixed, continuous ground planes. The main advantage of this innovation is that the moving contacts can be easily activated, yet maintain high-isolation and low-insertion loss.

The RF contact configuration is designed for controlled wiping action. Since the outer conductor is not part of the switching function, repeatability and life are improved. The switching action occurs typically within 15 milliseconds, after which permanent magnets latch the contacts to retain the new switch position.

Operation

All switches are “break before make”, the switched ports are not connected to each other. This prevents damage to sensitive circuits and enhances test simplicity.

Driving

There are two positions for the N181x family of switches. Standard switching is accomplished by applying the supply voltage to pin 5 (+V) and grounding either pin 4 (A) or pin 3 (B) to actuate the mechanism to the desired state. See page 5, pin-out diagram.

Warning minimum switch spacing is 6.0 mm (0.25 inch).

The N181x comes with current interrupt, the drive current is automatically disconnected after the switch is fully latched (15 ms).

Note: Prior to current interrupts becoming standard on the N181x, Option 403 current interrupt was available for ordering.

Option 401 drives the switch with TTL/5V CMOS compatible logic, which controls the DC power supply to drive the switch.

Option 402 provides electronic indication of switch state. The circuitry consists of two independent commons, which can be connected to outputs corresponding to either position A or B. Because the commons are electrically isolated from each other as well as the drive circuit, this option allows two position signals to be obtained.

Specifications

Specifications describe the instrument's warranted performance. **Supplemental and typical characteristics** are intended to provide information useful in applying the instrument by giving typical, but not warranted performance parameters.

General

Input power (into load)	1 W, 7 V DC, 50 W pk, 10 μs max pulse duration, not to exceed 1 W avg
Input power (into thru)	2 W, 7 V DC, 50 W pk, 10 μs max pulse duration, not to exceed 2 W avg
Coil voltage	5, 15, 24 VDC
Connector	SMA (f), 2.4 mm (f), 2.92 mm (f) and 1.85 mm (f)

Standard performance specifications - N1810/1/2 Series (Frequency Options 004/020/026)

Isolation (dB) = $90 - \left(\frac{30}{26.5}\right) F$, where F is specified in GHz

DC	4 GHz	12.4 GHz	20 GHz	26.5 GHz
90	85	76	67	60

Insertion loss (dB) = $0.35 + \left(\frac{.45}{26.5}\right) F$, where F is specified in GHz

DC	4 GHz	12.4 GHz	20 GHz	26.5 GHz
0.35	0.42	0.56	0.69	0.80

SWR	DC-4 GHz	4-12.4 GHz	12.4-20 GHz	20-26.5 GHz
	1.15	1.25	1.30	1.60

Standard performance specifications - N1810/1/2 Series (Frequency Options: 040/050/067)

Isolation (dB) = $100 - \left(\frac{30}{26.5}\right) F$, where F is specified in GHz (Formula Does not apply when F > 26.5 GHz)

DC	4 GHz	12.4 GHz	20 GHz	26.5 GHz	40 GHz	50 GHz	67 GHz
100	95	85	77	70	70	70	70

Insertion loss (dB)

Frequency Option 040: $0.35 + \left(\frac{0.45}{26.5}\right) F$, where F is specified in GHz (DC to 40 GHz)

Frequency Option 050: $0.2 + \left(\frac{0.80}{50}\right) F$, where F is specified in GHz (DC to 50 GHz)

Frequency Option 067: $0.35 + \left(\frac{0.45}{26.5}\right) F$, where F is specified in GHz (DC to 26.5 GHz)

$0.59 + \left(\frac{0.53}{67}\right) F$, where F is specified in GHz (26.5 to 67 GHz)

	DC	4 GHz	12.4 GHz	20 GHz	26.5 GHz	40 GHz	50 GHz	67 GHz
Option 040	0.35	0.41	0.56	0.68	0.80	1.02	-	-
Option 050	0.20	0.26	0.40	0.52	0.62	0.84	1.00	-
Option 067	0.35	0.41	0.56	0.68	0.80	0.91	0.99	1.12

SWR	DC	4 GHz	12.4 GHz	20 GHz	26.5 GHz	40 GHz	50 GHz	67 GHz
Option 040	1.15	1.15	1.25	1.40	1.60	1.80	-	-
Option 050	1.15	1.15	1.25	1.50	1.60	1.80	1.80	-
Option 067	1.15	1.15	1.25	1.30	1.70	1.90	1.90	1.90

Specifications *(continued)*

Optional high-performance specifications - N1810/1/2 Series (not applicable for Frequency Options 040/050/067)

Isolation (dB) = $125 - \left(\frac{35}{26.5}\right) F$, where F is specified in GHz

	DC	4 GHz	12.4 GHz	20 GHz	26.5 GHz
Option 301¹	125	120	109	99	90

	DC	4 GHz	12.4 GHz	20 GHz	26.5 GHz
Option 302	0.2	0.27	0.41	0.53	0.65

SWR	DC-4 GHz	4-12.4 GHz	12.4-20 GHz	20-26.5 GHz
Option 302	1.10	1.20	1.23	1.45

1. Option 301:

Environmental: Storage and cycling temperature: -55 C to +65 C

Environmental: Operating temperature: -25 C to +65 C

N1810UL

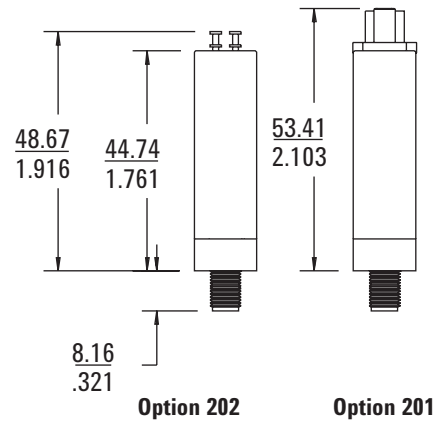
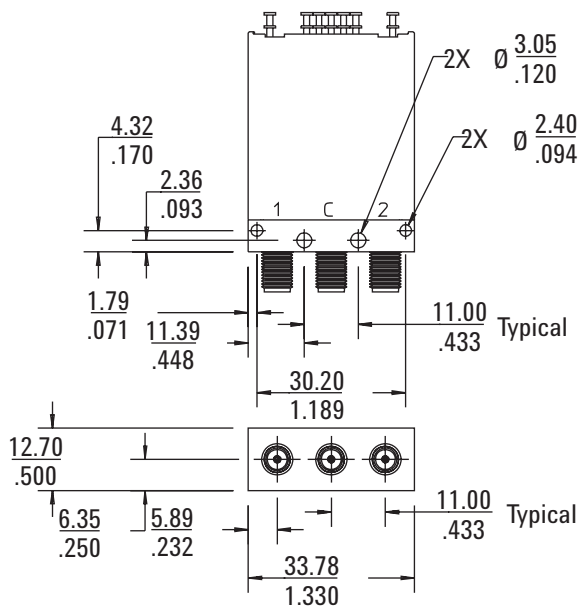
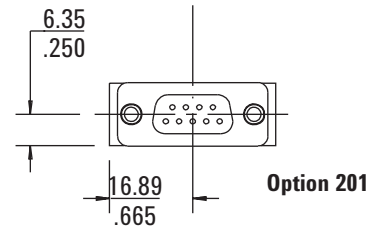
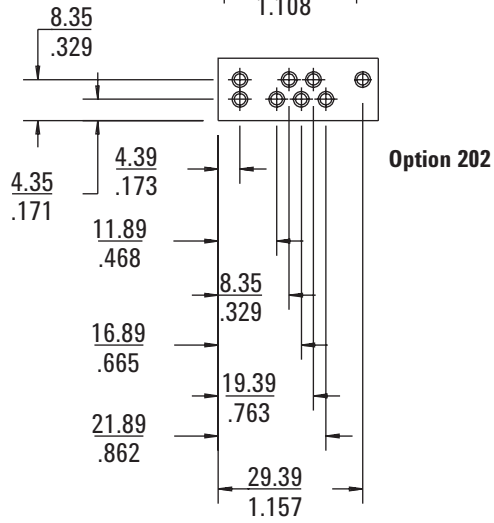
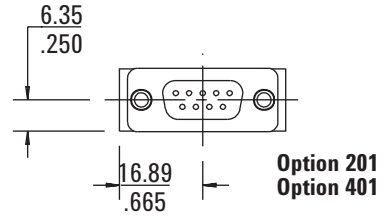
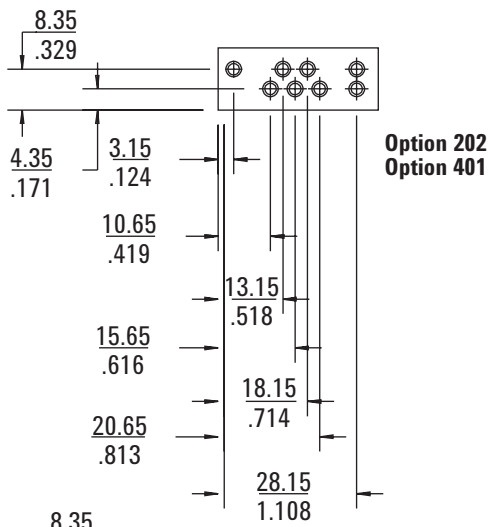

N1810UL

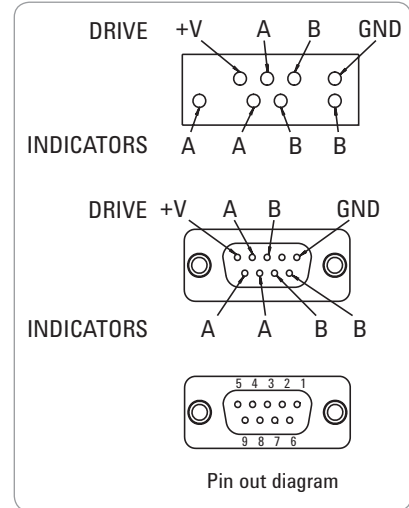
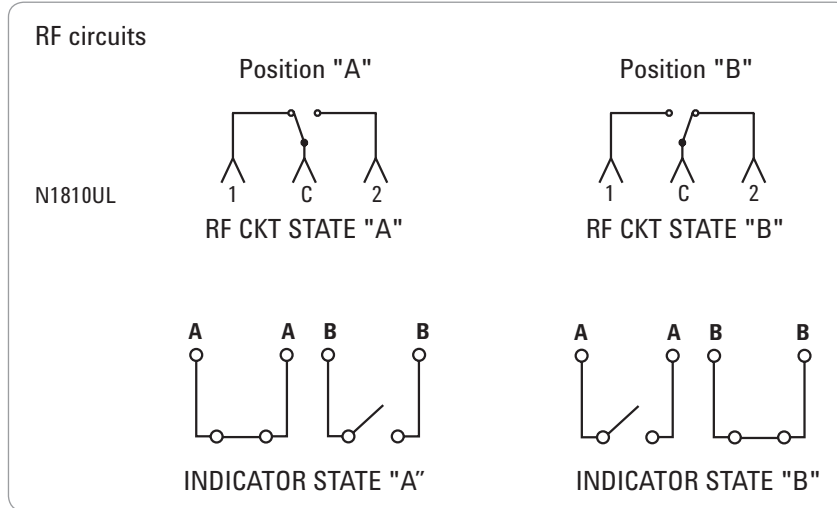

Switch drive specifications N1810UL

Option	Parameter	Conditions	Min	Nominal	Max	Units
105	Supply voltage		4.5	5	7.0	V
	Supply current	Supply voltage = 5 V		300		mA
115 ¹	Supply voltage		12.0	15	20.0	V
	Supply current	Supply voltage = 15 V		125		mA
124 ²	Supply voltage		20.0	24	32.0	V
	Supply current	Supply voltage = 24 V		75		mA

TTL drive specifications

Option	Parameter	Conditions	Min	Nominal	Max	Units	
401	High level input		3.0		12.0	V	
	Low level input		0.0		1.0	V	
	Max input current	Input voltage = 12.0 V				1.0	mA
		Input voltage = 3.85 V		0.25		0.5	mA

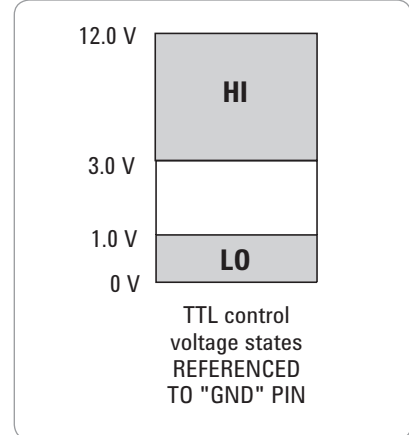

Driving the switch*

STD drive connect		TTL drive connect		RF state	INDICATOR state
GND to ground		GND to ground			
A	B	A	B		
GND	OPEN	Hi	Lo	"A"	"A"
OPEN	GND	Lo	Hi	"B"	"B"
GND	GND	Hi	Hi	Switching disabled **	NA
OPEN	OPEN	Lo	Lo	Switch remains at previous state	NA

GND: +V - Vsupply (see switch drive specification table, this page)

OPEN* +V to +v - 1.5 volts

Hi 3.0 V to 12.0 V

Lo 0.0 V to 1.0 V Warning drive level below -.25 V will damage TTL drive circuit!

* WARNING! Use adapter cable 11764-60011 with 87130A switch driver

** WARNING! Driving both select lines will disable switch
WARNING! Minimum switch spacing 6.0 mm (0.25 inch)

- Option 115: Characteristic life: 5 million cycles minimum, except 1 million cycles minimum when driven at voltages 18-20 VDC.
- Option 124: Characteristic life: 5 million cycles minimum, except 1 million cycles minimum when driven at voltages 28-32 VDC.

N1810TL

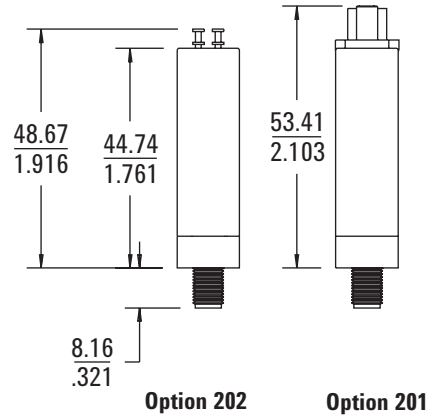
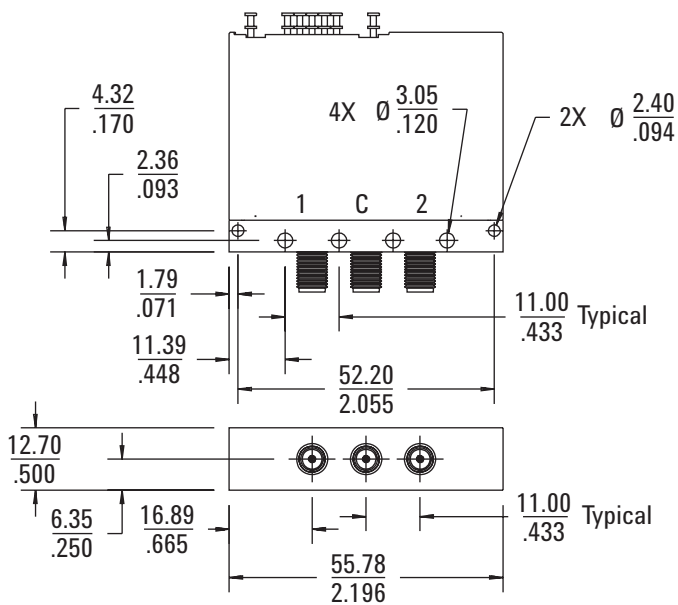
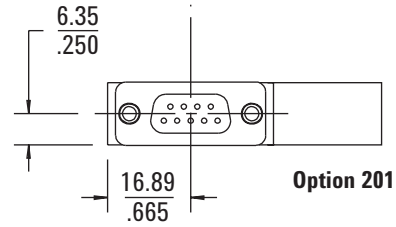
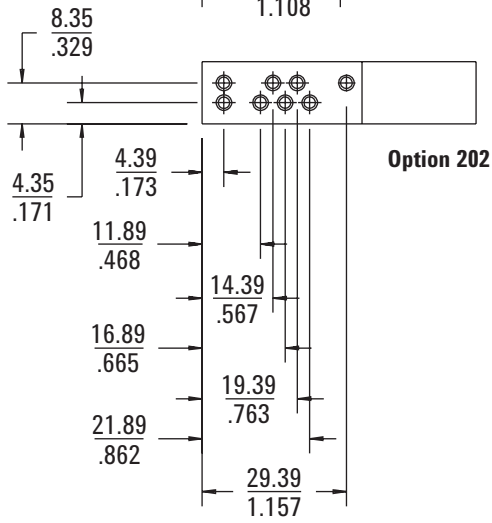
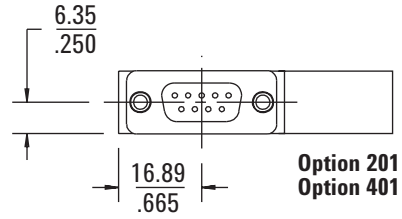
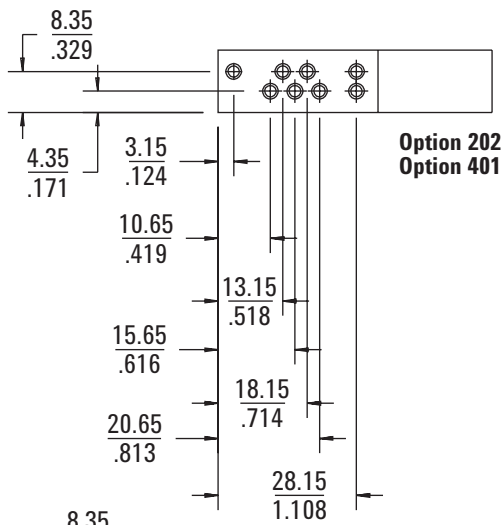

N1810TL

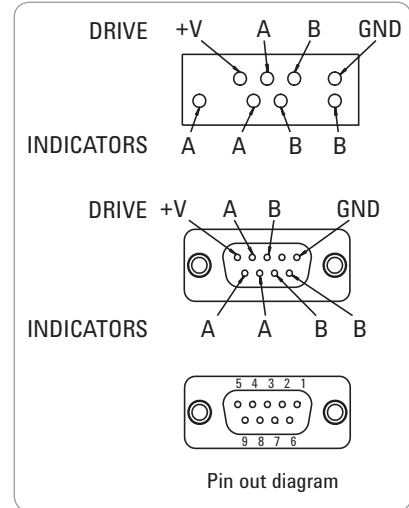
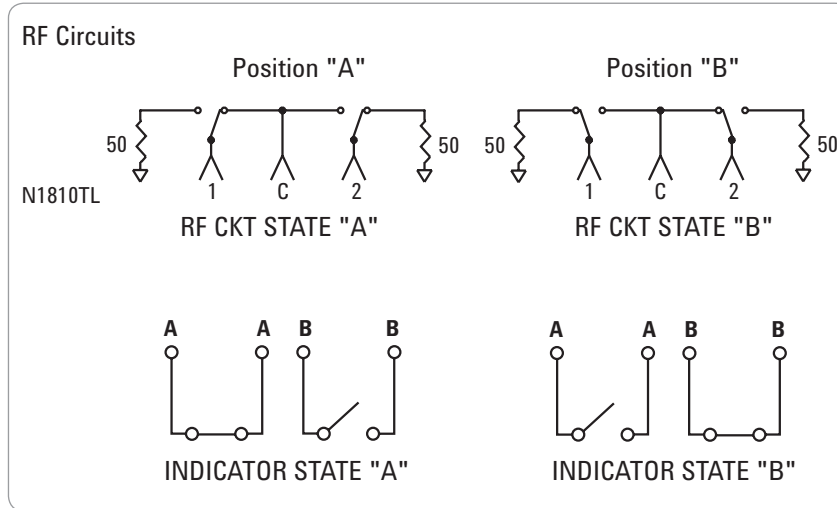

Switch drive specifications N1810TL, N1811TL, N1812UL

Option	Parameter	Conditions	Min	Nominal	Max	Units
105	Supply voltage		4.5	5	7.0	V
	Supply current	Supply voltage = 5 V		600		mA
115 ¹	Supply voltage		12.0	15	20.0	V
	Supply current	Supply voltage = 15 V		250		mA
124 ²	Supply voltage		20.0	24	32.0	V
	Supply current	Supply voltage = 24 V		150		mA

TTL drive specifications

Option	Parameter	Conditions	Min	Nominal	Max	Units	
401	High level input		3.0		12.0	V	
	Low level input		0.0		1.0	V	
	Max input current	Input voltage = 12.0 V				1.0	mA
		Input voltage = 3.85 V		0.25		0.5	mA

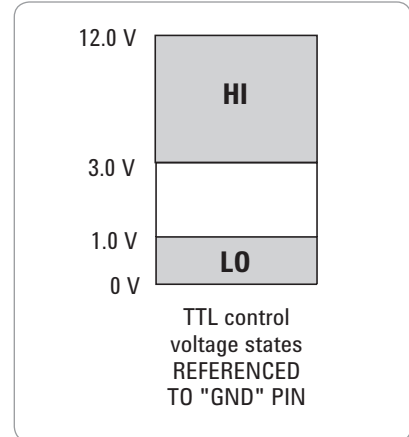

Driving the switch*

STD drive connect		TTL drive connect		RF state	INDICATOR state
A	B	A	B		
GND	OPEN	Hi	Lo	"A"	"A"
OPEN	GND	Lo	Hi	"B"	"B"
GND	GND	Hi	Hi	Switching disabled **	NA
OPEN	OPEN	Lo	Lo	Switching disabled **	NA

GND: +V - Vsupply (see switch drive specification table, this page)

OPEN* +V to +v - 1.5 volts

Hi 3.0 V to 12.0 V

Lo 0.0 V to 1.0 V Warning drive level below -0.25 V will damage TTL drive circuit!

* WARNING! Use adapter cable 11764-60011 with 87130A switch driver

** WARNING! Driving both select lines will disable switch (see troubleshoot guide)

WARNING! Minimum switch spacing 6.0 mm (0.25 inch)

- Option 115: Characteristic life: 5 million cycles minimum, except 1 million cycles minimum when driven at voltages 18-20 VDC.
- Option 124: Characteristic life: 5 million cycles minimum, except 1 million cycles minimum when driven at voltages 28-32 VDC.

N1811TL

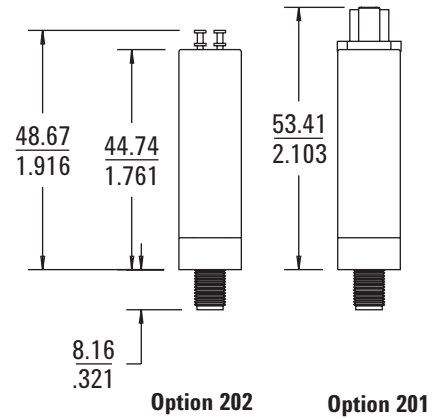
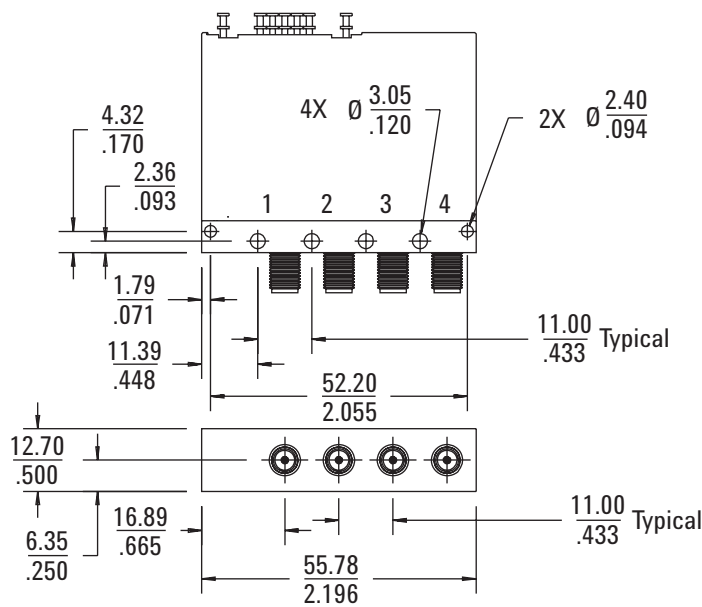
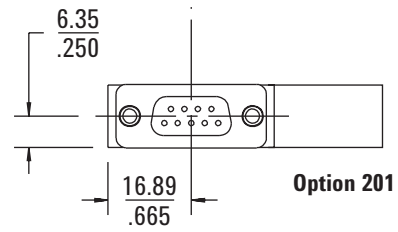
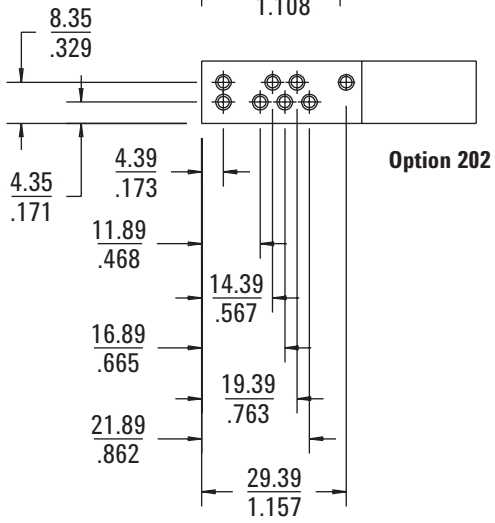
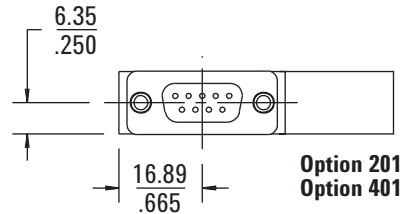
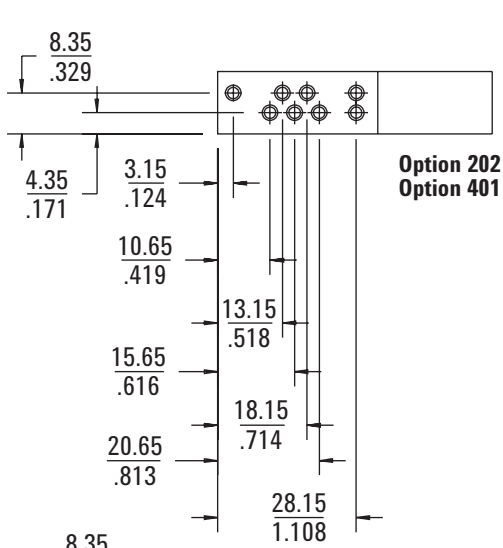

N1811TL

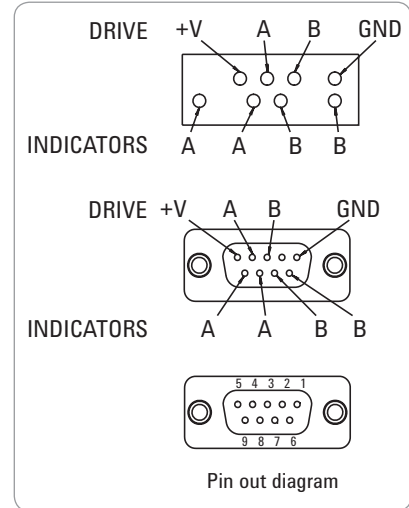
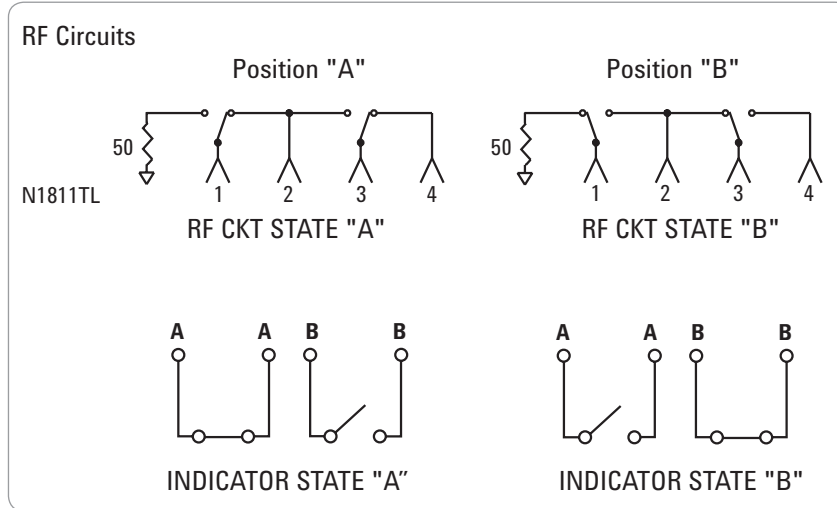

Switch drive specifications N1810TL, N1811TL, N1812UL

Option	Parameter	Conditions	Min	Nominal	Max	Units
105	Supply voltage		4.5	5	7.0	V
	Supply current	Supply voltage = 5 V		600		mA
115 ¹	Supply voltage		12.0	15	20.0	V
	Supply current	Supply voltage = 15 V		250		mA
124 ²	Supply voltage		20.0	24	32.0	V
	Supply current	Supply voltage = 24 V		150		mA

TTL Drive specifications:

Option	Parameter	Conditions	Min	Nominal	Max	Units
401	High level input		3.0		12.0	V
	Low level input		0.0		1.0	V
	Max input current	Input voltage = 12.0 V			1.0	mA
		Input voltage = 3.85 V		0.25	0.5	mA

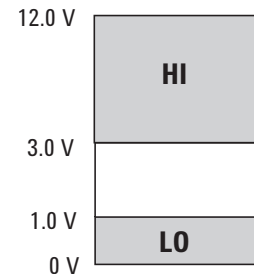

TTL control voltage states REFERENCED TO "GND" PIN

Driving the switch*

STD drive connect		TTL drive connect		RF state	INDICATOR state
A	B	A	B		
GND	OPEN	Hi	Lo	"A"	"A"
OPEN	GND	Lo	Hi	"B"	"B"
GND	GND	Hi	Hi	Switching disabled **	NA
OPEN	OPEN	Lo	Lo	Switching disabled **	NA

GND: +V - Vsupply (see switch drive specification table, this page)

OPEN* +V to +v - 1.5 volts

Hi 3.0 V to 12.0 V

Lo 0.0 V to 1.0 V Warning drive level below -.25 V will damage TTL drive circuit!

* WARNING! Use adapter cable 11764-60011 with 87130A switch driver

** WARNING! Driving both select lines will disable switch (see troubleshoot guide)

WARNING! Minimum switch spacing 6.0 mm (0.25 inch)

1. Option 115: Characteristic life: 5 million cycles minimum, except 1 million cycles minimum when driven at voltages 18-20 VDC.

2. Option 124: Characteristic life: 5 million cycles minimum, except 1 million cycles minimum when driven at voltages 28-32 VDC.

N1812UL

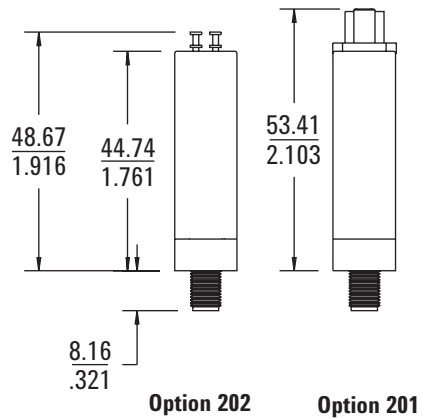
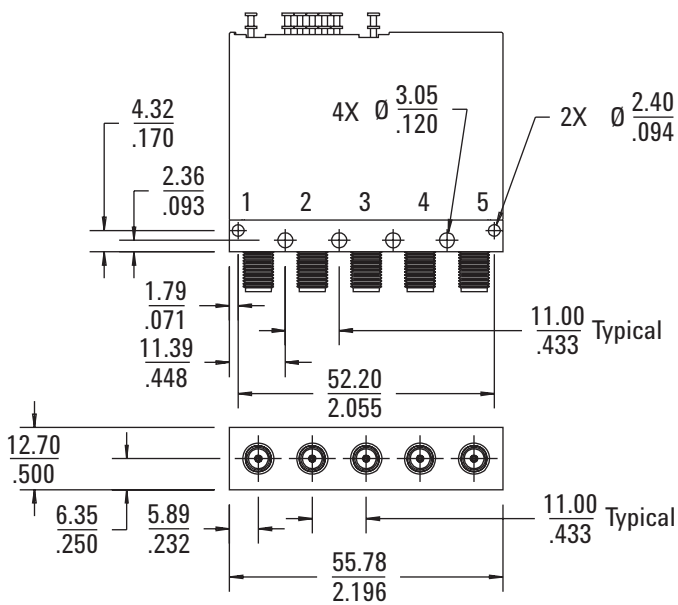
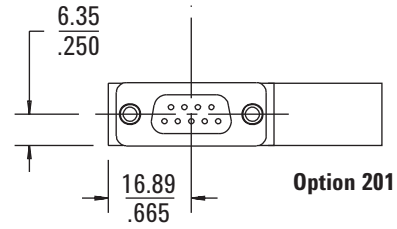
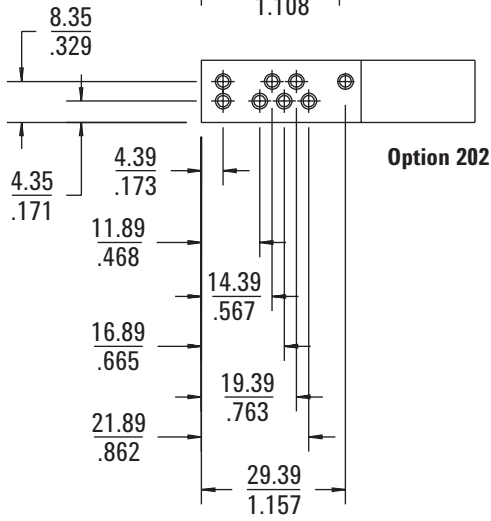
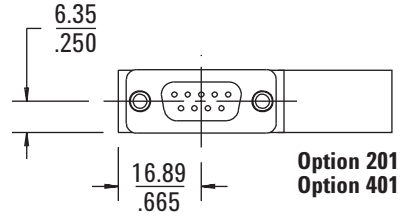
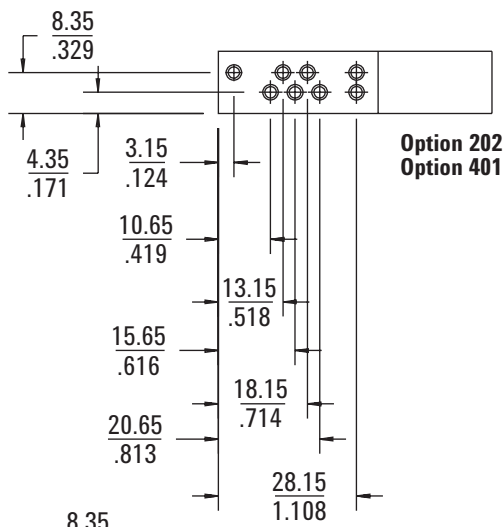

N1812UL

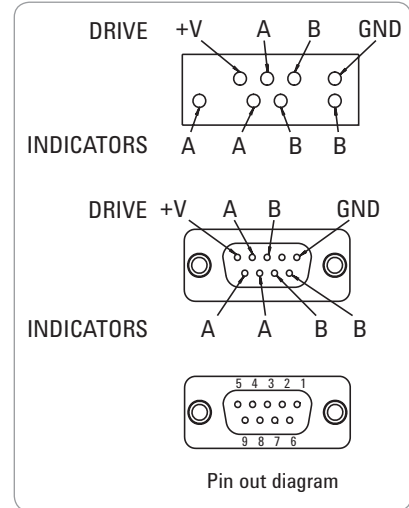
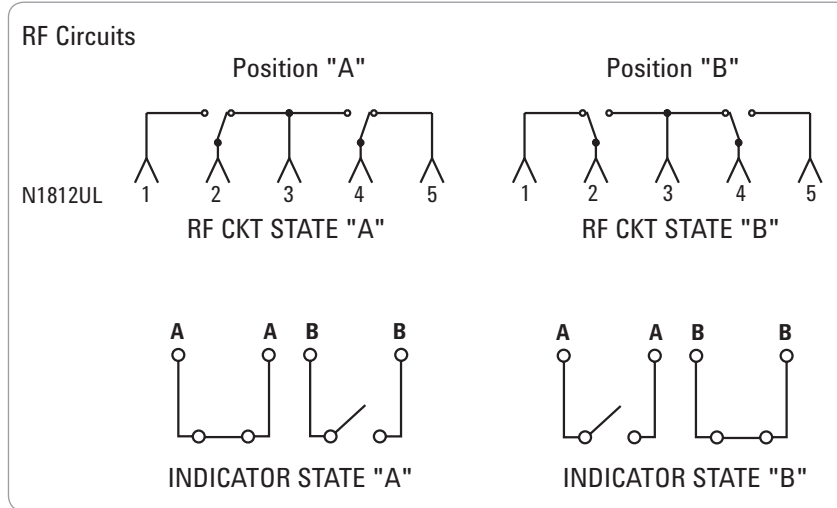

Switch drive specifications N1810TL, N1811TL, N1812UL

Option	Parameter	Conditions	Min	Nominal	Max	Units
105	Supply voltage		4.5	5	7.0	V
	Supply current	Supply voltage = 5 V		600		mA
115 ¹	Supply voltage		12.0	15	20.0	V
	Supply current	Supply voltage = 15 V		250		mA
124 ²	Supply voltage		20.0	24	32.0	V
	Supply current	Supply voltage = 24 V		150		mA

TTL drive specifications

Option	Parameter	Conditions	Min	Nominal	Max	Units	
401	High level input		3.0		12.0	V	
	Low level input		0.0		1.0	V	
	Max input current	Input voltage = 12.0 V				1.0	mA
		Input voltage = 3.85 V		0.25	0.5		mA

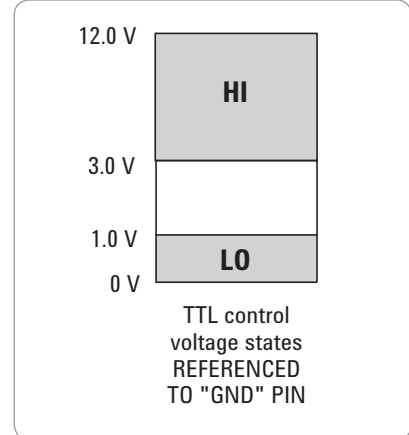

Driving the switch*

STD drive connect		TTL drive connect		RF state	INDICATOR state
GND to ground		GND to ground			
A	B	A	B		
GND	OPEN	Hi	Lo	"A"	"A"
OPEN	GND	Lo	Hi	"B"	"B"
GND	GND	Hi	Hi	Switching disabled **	NA
OPEN	OPEN	Lo	Lo	Switching disabled **	NA

GND: +V - Vsupply (see switch drive specification table, this page)

OPEN* +V to +v - 1.5 volts

Hi 3.0 V to 12.0 V

Lo 0.0 V to 1.0 V Warning drive level below -25 V will damage TTL drive circuit!

* WARNING! Use adapter cable 11764-60011 with 87130A switch driver

** WARNING! Driving both select lines will disable switch (see troubleshoot guide)
WARNING! Minimum switch spacing 6.0 mm (0.25 inch)

- Option 115: Characteristic life: 5 million cycles minimum, except 1 million cycles minimum when driven at voltages 18-20 VDC.
- Option 124: Characteristic life: 5 million cycles minimum, except 1 million cycles minimum when driven at voltages 28-32 VDC.

Supplemental Characteristics

General operating characteristics - N181x series

Switching speed	Repeatability	Life^{1,2}	Impedance
< 15 ms	0.03 dB at 40 GHz 0.05 dB at 50 GHz 0.08 dB at 67 GHz	> 5 million cycles	50 ohms

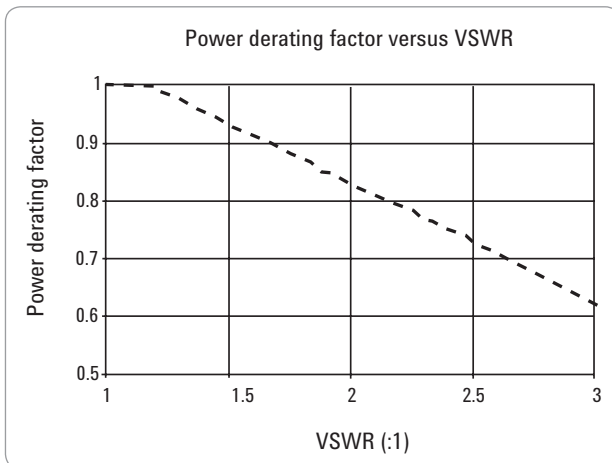
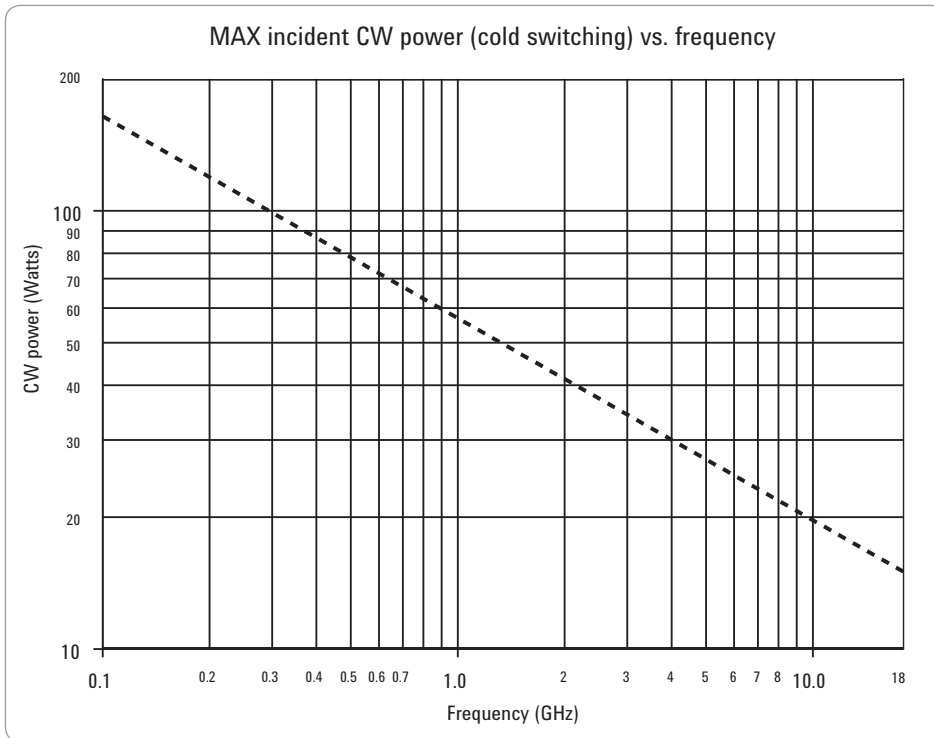

Reference conditions

- Cold switching only (NO hot switching)
- Ambient temperature of 75 °C or less³
- Sea level (0.88 derating at 15,000 ft.)
- Load VSWR < 1.2 (see graph for derating above 1.2 VSWR)
- Power Handling at 25° C is 100 W at 4 GHz

1. Option 115: Characteristic life: 5 million cycles minimum, except 1 million cycles minimum when driven at voltages 18-20 VDC.
2. Option 124: Characteristic life: 5 million cycles minimum, except 1 million cycles minimum when driven at voltages 28-32 VDC.
3. Option 301:
Environmental: Storage and cycling temperature: -55 C to +65 C
Environmental: Operating temperature: -25 C to +65 C

Environmental

The switch is designed to fully comply with Agilent Technologies' product operating environment specifications. The following summarizes the environmental specifications for these products (Class B1).

Temperature¹

Operating: -25 to +75 °C
 Storage: -55 to +85 °C
 Cycling: -55 to +85 °C, 10 cycles per MIL-STD 202F, 170D, Condition A
 (modified)

Vibration

Operating: 7 g, 5-2000 Hz at 0.25 in. p-p
 Survival: 20 g, 20-2000 Hz at 0.06 in. p-p, 4 min/cycle, 4 cycles/axis
 Random: 2.41 g (rms.) 10 min/axis
 Shock: Half sine: 500 g at 0.5 ms, 3 drops/direction, 18 total
 Operating: 50 g at 6 ms, 6 directions

Humidity

Operating: 15 to 95 % relative humidity
 Storage: 65 °C, 95 % RH, 10 days, MIL-STD 202F, Method 106E

Altitude

Operating: 15,000 feet / 4.6 km
 Storage: 50,000 feet / 15.3 km, MIL-STD 202F, Method 105C, Condition B

Troubleshoot guide				
Probable cause	Test	Allowable range		Remedy
		Low value	High value	
Not connected to supply		See drive specifications		Connect +V to power supply
Supply not turned on				Turn on power supply
Supply voltage less than minimum	Measure voltage from control pin to +V	See drive specifications		
Supply current low	Measure current draw with drive pin selected	See drive specifications		Increase drive voltage or reduce drive line resistance
OPEN state voltage too low	Measure voltage from control pin to +V	(+V-1.5) volts		+V volts
Select lines not at ground (STD DRIVE)	Measure voltage from drive select pin to ground			Eliminate ground loops and lead high resistance
TTL "LOW" voltage too high	Measure voltage from ground pin to TTL drive pin	See drive specifications		Connect ground pin to ground
TTL "LOW" voltage < 0.0 volts	Measure voltage from ground pin to TTL drive pin	See drive specifications		Eliminate ground loops
TTL GND pin not grounded				Connect GND pin to ground
Driving switch with 87130A				Use adapter cable 11764-60011

1. Option 301:

Environmental: Storage and cycling temperature: -55 C to +65 C

Environmental: Operating temperature: -25 C to +65 C

Ordering Information

Required: Specify one model number, one frequency range, one coil voltage, and one DC connector type (**must select one of each**)

Optional: Specify RF performance enhancements and drive options (**may select any, all, or none**)

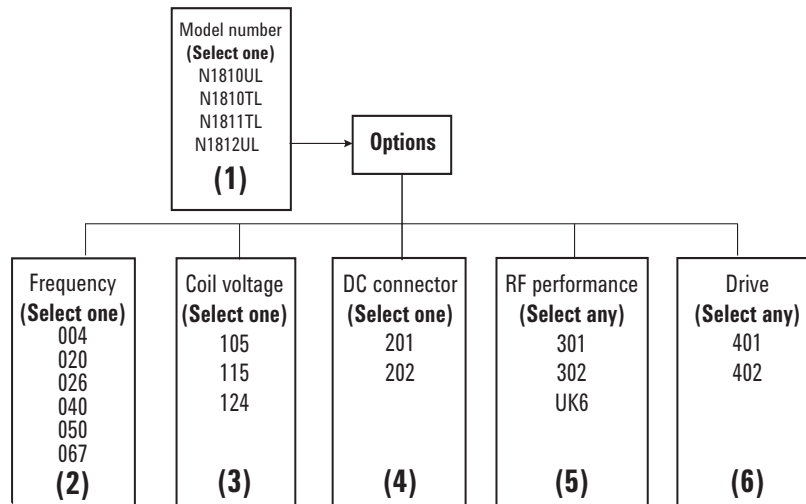

(1) Select a model to fit your application. **(Required)**

N1810UL – Underterminated latching 3-port
 N1810TL – Terminated latching 3-port
 N1811TL – Terminated latching 4-port
 N1812UL – Underterminated latching 5-port

(2) Select a frequency range. **(Required)**

004 – DC to 4 GHz
 020 – DC to 20 GHz
 026 – DC to 26.5 GHz
 040 – DC to 40 GHz
 050 – DC to 50 GHz
 067 – DC to 67 GHz

(3) Select a coil voltage level. **(Required)**

105* – 5 volts
 115 – 15 volts
 124 – 24 volts

(4) Select a DC connector type. **(Required)**

201 – “D” subminiature 9 pin female
 202 – Solder lugs

(5) Select RF performance enhancements. **(Optional)**

301 – Increased isolation
 302 – Reduced standing wave ratio and insertion loss
 UK6 – Calibration certificate with test data

(6) Select drive options. **(Optional)**

401 – TTL/CMOS compatible 5 v drive
 402 – Position indicators

Ordering example

For an unterminated 5 port switch, operating up to 20 GHz, with 15 volt coils, D-sub connector, high isolation, and TTL, the order should look as follows: N1812UL Option 020 115 201 301 401.

Switch units beginning with the serial numbers listed below or higher have current interrupt built-in as a default.

- N1810UL-MY07244672
- N1810TL-MY07247927
- N1811TL-MY07244660
- N1812UL-MY07240668

*Includes options 402

Related Literature

Agilent Technologies Bench and System Switching Products Literature Number 5989-9872EN

Agilent RF and Microwave Switch Selection Guide Literature Number 5989-6031EN

Agilent 11713B/C Attenuator/Switch Drivers Configuration Guide Literature Number 5989-7277EN

Application Notes:

Power Handling Capability of Electro-mechanical Switches Literature Number 5989-6032EN

How Operating Life and Repeatability of Agilent's Electromechanical Switches Minimize System Uncertainty Literature Number 5989-6085EN



Agilent Advantage Services is committed to your success throughout your equipment's lifetime. To keep you competitive, we continually invest in tools and processes that speed up calibration and repair and reduce your cost of ownership. You can also use Infoline Web Services to manage equipment and services more effectively. By sharing our measurement and service expertise, we help you create the products that change our world.

www.agilent.com/find/advantageservices



www.agilent.com/quality



Agilent Email Updates

www.agilent.com/find/emailupdates
Get the latest information on the products and applications you select.



www.lxistandard.org
LAN eXtensions for Instruments puts the power of Ethernet and the Web inside your test systems. Agilent is a founding member of the LXI consortium.

Agilent Channel Partners

www.agilent.com/find/channelpartners
Get the best of both worlds: Agilent's measurement expertise and product breadth, combined with channel partner convenience.

www.agilent.com
www.agilent.com/find/switches
www.agilent.com/find/mta

For more information on Agilent Technologies' products, applications or services, please contact your local Agilent office. The complete list is available at:

www.agilent.com/find/contactus

Americas

Canada	(877) 894 4414
Brazil	(11) 4197 3500
Mexico	01800 5064 800
United States	(800) 829 4444

Asia Pacific

Australia	1 800 629 485
China	800 810 0189
Hong Kong	800 938 693
India	1 800 112 929
Japan	0120 (421) 345
Korea	080 769 0800
Malaysia	1 800 888 848
Singapore	1 800 375 8100
Taiwan	0800 047 866
Other AP Countries	(65) 375 8100

Europe & Middle East

Belgium	32 (0) 2 404 93 40
Denmark	45 70 13 15 15
Finland	358 (0) 10 855 2100
France	0825 010 700*
	*0.125 €/minute
Germany	49 (0) 7031 464 6333
Ireland	1890 924 204
Israel	972-3-9288-504/544
Italy	39 02 92 60 8484
Netherlands	31 (0) 20 547 2111
Spain	34 (91) 631 3300
Sweden	0200-88 22 55
United Kingdom	44 (0) 131 452 0200

For other unlisted countries:

www.agilent.com/find/contactus

Revised: June 8, 2011

Product specifications and descriptions in this document subject to change without notice.

© Agilent Technologies, Inc. 2001, 2002, 2007, 2009-2011
Published in USA, September 28, 2011
5968-9653E



Agilent Technologies