

Agilent N77-Series Attenuators

N7751A 1-Channel Optical Attenuator and Power Meter

N7752A 2-Channel Optical Attenuator and Power Meter

N7761A 1-Channel Optical Attenuator

N7762A 2-Channel Optical Attenuator

N7764A 4-Channel Optical Attenuator

N7766A 2-Channel Multimode Optical Attenuator

N7768A 4-Channel Multimode Optical Attenuator

Data Sheet

Version 2.2



Agilent Technologies

Introduction

The Agilent N775xA and N776xA series compact multi-channel attenuators and power meters are a new class of remote controlled fiberoptic instruments for optical transceiver and network integration test. High setting speed of attenuation and power as well as power measurement capability, combined with USB, LAN and GPIB interfaces provides increased throughput and operational efficiency to meet today's challenges in manufacturing.

Operation Modes

All attenuators feature both attenuation mode and power control mode.

In attenuation mode, the calibrated value of attenuation in dB can be set. The attenuation can be changed at up to 1000 dB/s or the rate can be set to values in the range 0-1000 dB/s for single-mode and 0-80dB/s for multimode units.

The power control functionality allows you to set the power level at the attenuator output. The instrument uses the feedback signal from a photodiode after a monitor tap, both integrated in the instrument, to set the desired power level at the output of the module (Figure 1 and Figure 2).

When the power control mode is enabled, the module automatically corrects for power changes at the input so that the output power level you set is maintained. Absolute power levels can be set with high accuracy after an initial offset calibration for the uncertainties at connector interfaces.

Power measurements

In addition, the Agilent N7751A and N7752A attenuators include two extra optical power meter channels for convenient power measurements and setup calibration.

User calibration processes

Comprehensive offset functionality allows you to calibrate the optical path in various test set-ups. There is an offset for the attenuation factor, and an independent offset for the output power level, to calibrate for losses due to patch cords, connectors and switches. Additionally, wavelength and offset value pairs can be stored in a table to compensate for wavelength-dependent effects in the optical path of the set-up. This allows you to precisely set the optical power level directly at the input interface of your device under test. With the extra optical power meter channel, calibration is even easier and more convenient. All power related offsets can be determined by a firmware function that reads a value from the reference power meter. The difference between the power value read by the reference power meter and the actual value of the attenuator is automatically stored as the offset.

Key specifications and features

- 0.05 dB relative power setting accuracy, 0.1 dB for multimode
- Settling time: 20 ms attenuation, 100 ms power, 200 ms multimode
- Accurate built-in power monitor
- Miniature bulk optics for multimode for best transfer of modal distribution
- Choice of FC/PC or FC/APC connectors for 9/125 μm SMF models
- Choice of 50, 62.5 or 80 μm core fiber type for multimode models
- 0.1 to 1000 dB/s or for multimode to 80 and 1000 dB/s attenuation transition speed (selectable)
- +23 dBm max. input power
- ≤ 1.2 dB (typ. 1.3 dB MMF) insertion loss
- 45 dB single-mode attenuation range (typ.)
- 35 dB multimode attenuation range
- -50 dBm to +20 dBm power setting range (-35 to +20 dBm MMF)
- One half-width rack unit
- Fully compatible with setups and programs developed using the Agilent 8157x modular attenuators
- Powerful and user-friendly GUI software
- Two instrument configurations can be stored and recalled

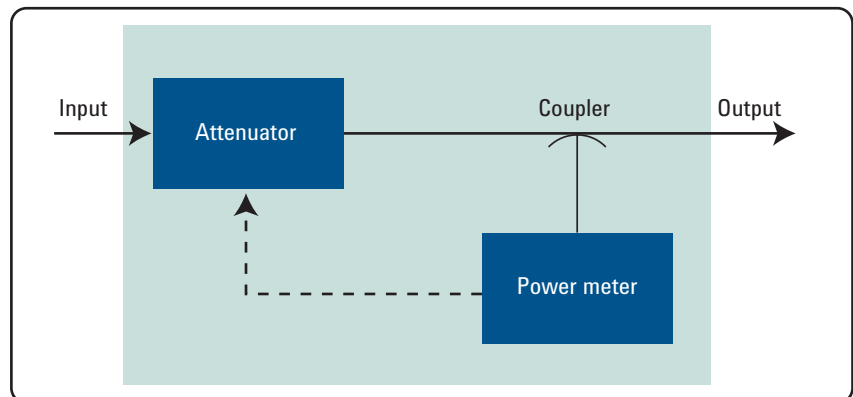

Figure 1. Optical Attenuator with power control

The Multi-Channel Attenuator Series – Product Configurations

N776xA multi-channel optical attenuators with internal power control

The Agilent N776xA multichannel optical attenuators with 1, 2 and 4 attenuator channels in one unit provide an excellent combination of versatility and density.

1-channel variable attenuator N7761A



2-channel N7762A SMF attenuator or N7766A MMF attenuator



4-channel N7764A SMF attenuator or N7768A MMF attenuator



N775xA multi-channel optical attenuators with internal power control and external power meter channels

The Agilent N775xA multichannel optical attenuators offer 1 or 2 attenuator channels combined with two power meter channels in one unit.

1-channel attenuator with two power meter channels N7751A



2-channel attenuator with two power meter channels N7752A



Benefits

Compact instrument combines and integrates multiple functions for setting attenuation and power levels and optical power measurement to reduce CAPEX and floor space.

- Fast and precise setting of optical power levels in parallel with settling times of 100 ms (200ms multi-mode) for improved throughput.
- The multichannel attenuator sets and measures several ports at the same time, saving significant time characterizing multiport and multi-channel components and network equipment.
- Miniature bulk optics for multi-mode avoids distortion of modal distribution and assures stability and accurate power monitoring.
- Active power control keeps output power constant.
- The instrument can be controlled via LAN and USB, as well as GPIB for compatibility with existing equipment.
- An easy-to-use and intuitive graphical user interface speeds up the integration process.

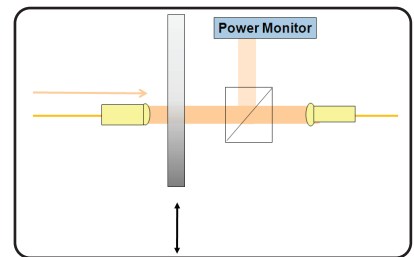

Figure 2. Schematic of multimode attenuator with collimated beam path for homogeneous attenuation and monitoring.

The N77xx-Viewer: An easy-to-use graphical user interface

The N77xx Windows-based graphical user interface offers flexible and convenient control of the instrument.

- Easy switching between channels with tabs.
- Overview window with all channels at a glance.
- Two instrument configurations can be stored and recalled.
- Enable or disable the attenuator's output with one click.
- Choose between setting an attenuator or an output power.

Applications

Optical transceiver testing

One of the challenges in testing transceivers is parallelization of bit-error-ratio measurements for multiple-device and multichannel device measurements. Sensitivity measurements require fast and precise setting of optical power levels in parallel at the receiver inputs with settling times like 100 ms for improved throughput.

Modal fidelity for multimode fiber setups

Signals in multimode fibers are distributed over a range of mode groups that can have different loss and delay in a link. For dependable multimode transceiver testing, the instrument used to set the power level should not change this modal distribution. The bulk-optic filter and collimated beam path of Agilent multimode attenuators are the best way to assure homogeneous attenuation of all input modes and to optimize stability.

Optical network integration testing

When integrating and testing network equipment to test network transmission performance and network management, including meshed networks using ROADMs, attenuators represent link spans between network nodes or amplifier stages.

The very fast attenuation and power setting response of the Agilent N775xA and N776xA attenuators allows simulation of many network configurations in a short time. In the path-blocking mode, fiber network cuts are emulated. With the attenuation and power ramp feature, the attenuation and/or the output power is changed at a defined rate of 0.1 dB/s to 1000 dB/s. This feature simulates slow and fast changes in the fiber network for testing the network management system.

Definitions

Generally, all specifications are valid at the stated operating and measurement conditions and settings, with uninterrupted line voltage.

Specifications (guaranteed) describe warranted product performance that is valid under the specified conditions. Specifications include guard bands to account for the expected statistical performance distribution, measurement uncertainties changes in performance due to environmental changes and aging of components.

Typical values (characteristics) describe the product performance that is usually met but not guaranteed. Typical values are based on data from a representative set of instruments.

General characteristics give additional information for using the instrument. These are general descriptive terms that do not imply a level of performance.

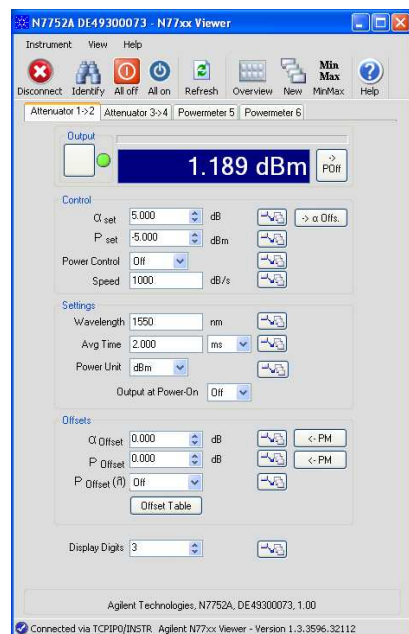
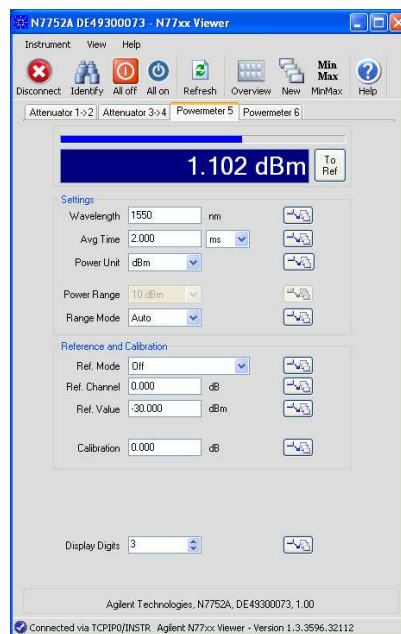
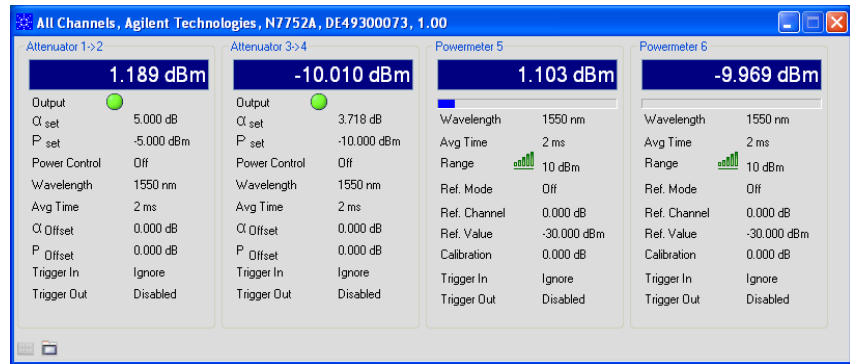

Technical Specifications

Table 1. Single-mode fiber optical attenuators

N7751A, N7752A, N7761A, N7762A, N7764A		
Connectivity	FC/APC angled (Option -022) or FC/PC straight (Option -021) contact connector interface	
Fiber type	9/125 μ m SMF 28	
Wavelength range	1260 nm to 1640 nm	
Attenuation range	0 dB to 40 dB (45 dB typ.)	
	Attenuation setting mode	Power setting mode
Range	0 dB to 40 dB	-50 dBm to +20 dBm
Resolution	0.01 dB	0.01 dB
Repeatability ¹	typ. +/- 0.05 dB for attenuation 0 dB to 30 dB typ. +/- 0.10 dB for attenuation 30 dB to 40 dB	\pm 0.025 dB
Accuracy (uncertainty) ¹⁻³	typ. \pm 0.10 dB for attenuation 0 dB to 10 dB typ. \pm 0.15 dB for attenuation 10 dB to 20 dB typ. \pm 0.40 dB for attenuation 20 dB to 40 dB	
Relative accuracy (uncertainty) ^{1,2,4}		\pm 0.05 dB \pm 300 pW
Polarization dependent loss ⁵	typ. \leq 0.15 dB _{pp} for attenuation 0 dB to 10 dB typ. \leq 0.25 dB _{pp} for attenuation 10 dB to 20 dB typ. \leq 0.5 dB _{pp} for attenuation 20 dB to 40 dB	\leq 0.15 dB _{pp} ⁶
Settling time	typ. 20 ms ⁷	typ. 100 ms ⁶
Insertion loss ⁸	typ. \leq 1.2 dB (excluding connectors) \leq 2.2 dB (including connectors) ⁹	
Attenuation transition speed	selectable from 0.1 to 1000 dB/s	
Relative uncertainty of monitor power meter ^{2,10}	\pm 0.05 dB \pm 300 pW	
Averaging time of monitor power meter	2 ms to 1 s	
Return loss	typ. 45 dB	
Maximum safe input power	+23 dBm if applied to input port; $<$ +18 dBm if applied to output port	
Optical path blocking	typ. 45 dB	

1. At constant operating conditions.

2. For unpolarized light. Temperature constant and between (23 ± 5) °C.

3. For (1310 ± 15) nm, (1490 ± 10) nm and (1550 ± 15) nm.

4. Output power $>$ -40 dBm, input power $<$ +10 dBm.
For input power $>$ +10 dBm add typ. \pm 0.02 dB.

5. For (1550 ± 15) nm. Add typ. 0.05 dB for (1310 ± 15) nm and (1490 ± 10) nm.

6. Output power $>$ -30 dBm, input power $<$ +10 dBm.

7. For 20 dB step.

8. For (1550 ± 15) nm. Add typ. 0.20 dB for (1310 ± 15) nm and (1490 ± 10) nm.

9. Measured with Agilent reference connectors.

10. For (1550 ± 15) nm.

Technical Specifications (continued)

Table 2. Multimode fiber optical attenuators

N7766A and N7768A		
Connectivity	FC/PC straight contact connector interface	
Fiber type	50/125 μm (Option 050) or 62.5/125 μm (Option 062) 80 μm -core (Option 080) MMF	
Wavelength range	800 nm to 1370 nm	
Attenuation range	0 dB to 35 dB	
	Attenuation setting mode	Power setting mode
Range	0 dB to 35 dB	-35 dBm to +20 dBm
Resolution	0.03 dB	0.03 dB
Repeatability ^{1, 2, 5}	± 0.025 dB	± 0.025 dB
Accuracy (uncertainty) ¹⁻⁵	± 0.25 dB; typ. ± 0.15 dB	
Relative accuracy (uncertainty) ¹⁻⁶		± 0.1 dB
Settling time (for 20 dB step)	typ. 200 ms	typ. 200 ms
Insertion loss ¹⁻⁵	≤ 2.0 dB; typ. ≤ 1.3 dB	
Attenuation transition speed	Selectable from 0.1 to 80 and 1000 dB/s	
Relative uncertainty of monitor power meter ¹⁻⁶	± 0.1 dB	
Averaging time of monitor power meter	2 ms to 1 s	
Return loss ^{2, 5, 7}	typ. 25 dB	
Maximum safe input power ^{3, 8}	+23 dBm	
Optical path blocking	typ. 60 dB	

1. At constant operating conditions.

2. Effective spectral bandwidth of input signal > 30 nm.

3. For mode launch conditions from IEEE 802.3: encircled flux $< 30\%$ in $4.5 \mu\text{m}$ radius and $> 86\%$ inside $19 \mu\text{m}$ for 50/125 μm fiber; $< 25\%$ inside $4.5 \mu\text{m}$ and $> 75\%$ inside $15 \mu\text{m}$ for 62.5/125 μm fiber; encircled flux $< 30\%$ in $7 \mu\text{m}$ radius and $> 86\%$ inside $30 \mu\text{m}$ for 80 μm -core fiber (scaled from 50/125 μm conditions).

4. For unpolarized light. Temperature constant and within $(23 \pm 5) ^\circ\text{C}$.

5. For (850 ± 15) nm and (1300 ± 15) nm; for (1060 ± 15) nm, add typ. ± 0.1 dB to accuracy (uncertainty), relative accuracy (uncertainty) and relative uncertainty of monitor power meter and add typ. 0.5 dB to insertion loss.

6. For 2 ms averaging time. Output power > -30 dBm, input power $< +10$ dBm, attenuation setting ≤ 30 dB.

7. The return loss is primarily limited by the return loss of the front-panel connections.

8. Agilent assumes no responsibility for damage caused by scratched or poorly cleaned connectors.

Technical Specifications (continued)

Table 4. Optical power meter

N7751A and N7752A	
Sensor element	InGaAs
Wavelength range	1260 nm to 1640 nm
Specification wavelength range	(1310 ± 15) nm, (1490 ± 10) nm, (1550 ± 15) nm
Power range	-80 dBm to +10 dBm
Maximum safe power	+16 dBm
Averaging time	2 ms to 1s
Applicable fiber type	Standard SM and MM ≤ 62.5 μm core size, NA ≤ 0.24
Uncertainty at reference conditions ^{1,3}	± 2.5%
Total uncertainty ^{2,5,6}	± 4.5%
Linearity ⁷ at (23 ± 5)°C over operating temperature	± 0.02 dB ± 0.04 dB
Polarization dependent responsivity (PDR) ^{3,8}	typ. < ± 0.01 dB (1260 nm to 1580 nm)
Spectral ripple (due to interference) ¹⁰	typ. < ± 0.01 dB
Drift (dark) ⁴	± 9 pW
Noise pp (dark) ³ , (1s averaging time, 300s observation time)	< 7 pW _{pp}
Return loss ⁹	typ. > 57 dB

1. Reference conditions:

Single mode fiber SMF 9 μm. Power Level: -20 dBm to 0 dBm.

On day of calibration (add ± 0.3% for aging over one year; add ± 0.6% for aging over two years).

Spectral width of source < 10 nm FWHM.

Wavelength setting of power sensor corresponds to source wavelength ± 0.4 nm.

2. Operating conditions:

Single mode fiber SMF. For multimode fiber, typical.

Within one year of calibration; add ± 0.3% for second year.

Spectral width of source < 10 nm FWHM.

Wavelength setting of power sensor corresponds to source wavelength ± 0.4 nm.

3. Ambient temperature (23 ± 5) °C.

4. Temperature constant within ± 1 K after zeroing.

5. Excluding noise and offset drift.

6. Power range -60 dBm to +10 dBm.

7. Power range -40 dBm to +10 dBm. For power < -40 dBm add 0.05 dB.

8. Straight connector, SMF.

9. Angled connector 8°, ceramic ferrule, SMF.

10. For constant state of polarization, source linewidth < 100 MHz, angled connector 8°, wavelength range 1260 nm to 1625 nm. Add ± 0.01 dB typ. within specification wavelength range for straight connector with ceramic ferrule.

General Characteristics

Dimensions (D x W x H):

1U half-rack
372 mm x 212 mm x 43 mm

for N7766A and N7768A
460 mm x 212 mm x 43 mm

(excluding front and back rubber cushions)

Weight:

Approx. 3 kg

Recommended recalibration period

24 month

Operating temperature

+5 °C to +40 °C

Operating humidity

15% to 95%, non-condensing

Altitude

The maximum operating altitude is 2000 m.

Pollution protection

The Agilent N775xA/6xA is designed for pollution degree 2.

Warm-up time

20 minutes

Interfaces

The instruments can be controlled via LAN, USB or GPIB interfaces

Power consumption

Line power: AC 100 - 240 V \pm 10%,
50/60 Hz, 60 VA max.

Ordering Information

All systems have 1 year warranty

Model number

N7751A	Optical attenuator (1 channel) with optical power meter (2 channels)
N7752A	Optical attenuator (2 channels) with optical power meter (2 channels)
N7761A	Optical attenuator (1 channel)
N7762A	Optical attenuator (2 channels)
N7764A	Optical attenuator (4 channels)
N7766A	Optical attenuator (2 channels multimode)
N7768A	Optical attenuator (4 channels multimode)

Connector interface options (for N7751A, N7752A, N7761A, N7762A, N7764A)

-021	Straight-contact FC/PC, 9/125 μ m SMF
-022	Angled-contact FC/APC, 9/125 μ m SMF

Multimode fiber options (for N7766A, N7768A)

-050	50/125 μ m MMF, straight-contact FC/PC connector
-062	60/125 μ m MMF, straight-contact FC/PC connector
-080	80 μ m-Core MMF, straight-contact FC/PC connector

Accessories

N7744-100	Rack Mount Kit for 1 or 2 Units
-----------	---------------------------------

Warranty

All systems have 1 year warranty

R-51B-001-3C	1 year Return-to-Agilent warranty extended to 3 years
R-51B-001-5C	1 year Return-to-Agilent warranty extended to 5 years

Calibration

R-50C-011-3	Agilent calibration upfront support plan 3 year coverage
R-50C-011-5	Agilent calibration upfront support plan 5 year coverage



Agilent Email Updates

www.agilent.com/find/emailupdates

Get the latest information on the products and applications you select.

Agilent Channel Partners

www.agilent.com/find/channelpartners

Get the best of both worlds: Agilent's measurement expertise and product breadth, combined with channel partner convenience.



Agilent Advantage Services is committed to your success throughout your equipment's lifetime. To keep you competitive, we continually invest in tools and processes that speed up calibration and repair and reduce your cost of ownership. You can also use Infoline Web Services to manage equipment and services more effectively. By sharing our measurement and service expertise, we help you create the products that change our world.

www.agilent.com/find/advantageservices



www.agilent.com/quality

www.agilent.com
www.agilent.com/find/voa

For more information on Agilent Technologies' products, applications or services, please contact your local Agilent office. The complete list is available at:

www.agilent.com/find/contactus

Americas

Canada	(877) 894 4414
Brazil	(11) 4197 3500
Mexico	01800 5064 800
United States	(800) 829 4444

Asia Pacific

Australia	1 800 629 485
China	800 810 0189
Hong Kong	800 938 693
India	1 800 112 929
Japan	0120 (421) 345
Korea	080 769 0800
Malaysia	1 800 888 848
Singapore	1 800 375 8100
Taiwan	0800 047 866
Other AP Countries	(65) 375 8100

Europe & Middle East

Belgium	32 (0) 2 404 93 40
Denmark	45 70 13 15 15
Finland	358 (0) 10 855 2100
France	0825 010 700*
	*0.125 €/minute
Germany	49 (0) 7031 464 6333
Ireland	1890 924 204
Israel	972-3-9288-504/544
Italy	39 02 92 60 8484
Netherlands	31 (0) 20 547 2111
Spain	34 (91) 631 3300
Sweden	0200-88 22 55
United Kingdom	44 (0) 131 452 0200

For other unlisted countries:

www.agilent.com/find/contactus

Revised: June 8, 2011

Product specifications and descriptions in this document subject to change without notice.

© Agilent Technologies, Inc. 2011
Published in USA, October 11, 2011
5990-4394EN



Agilent Technologies