

Support Information Only

NOTICE: Signametrics was acquired by Agilent Technologies in October 2010. This document, published prior to that date, is provided as a courtesy and may contain references to products or services no longer supported by Agilent. For the latest information on Agilent's modular test and measurement products go to: www.agilent.com/find/modular

Or in the US, call Agilent Technologies at 1-800-829-4444 (8am-8pm EST)

For other Countries: www.agilent.com/find/contactus

© Agilent Technologies, Inc. November 8, 2011
5990-9486EN



Agilent Technologies

35 Channel Relay Switching modules for PXI and USB

Features

- PXI or USB models
- Relay Multiplexer
- Reconfigurable on the fly
- Auto Scanning
- On-board Controller
 - Autonomous operation
 - Complex Operations
 - High Level Commands
- Flexible Architecture
 - 35 chan. 2-Wire Mux.
 - 16 chan. 4-Wire Mux.
 - 8 chan. 6-Wire Mux.
 - Matrix
 - Two groups of 16:1
 - Four groups of 8:1
 - Single-ended 64:1
- Lowest Thermal EMF
- Lowest noise
- Isolated power and controls
- Instrumentation quality
 - SMX4032, SMU4032
- Cost Effective
 - SMX4030, SMU4030
- Variable Actuation time
- Variable Actuation delay
- Break-Before-Make
- Triggered operations
- Sync output.
- Contact Cleaning
- Self tests
 - Shorts and opens
 - Stuck relay
 - Contacts resistance
 - Bounce & settle time
- Universal Software driver
 - Linux & Windows
 - Fast to install - tiny footprint
 - Compatible with most S/W
 - Stand alone – no dependencies
 - Excel, Word, MatLab, LabView, C, C++, C#, LabWindows, VB...



The *Signametrics* 4032 and 4030 models offer a superior functionality and performance, at unmatched prices. These flexible relay switching modules are designed for applications requiring both, performance and ease of use. They can be reconfigured on-the-fly as 35:1 differential or set to 16 channel 4-Wire multiplexers. Several other pre-set configurations are also available. For ultimate flexibility, the universal configuration provides control over each of the relays, independently.

Often ignored is the error contribution of the switching subsystem. Using the wrong switch can result in errors several orders of magnitude greater than expected. Employing an Instrumentation type 4032 model will have negligible signal degradation. Expect the general purpose 4030 model to perform 10 times better than most other USB and PXI switches.

Built-in intelligence relieves the host CPU, facilitating for high level commands. The benefit is a much simplified programming and speed. i.e., to multiplex a set of 4-Wire resistors, issue a configuration command to set it as a 4-Wire mux, and a command to select a channel. All currently closed channel relays will open and the selected two channel relays corresponding to the 4-Wire connection will close. All is done within a single actuation time. It is possible to efficiently mix devices requiring different configurations, without sacrificing channels. The number of channels per system is unlimited.

For Thermocouple (TC) multiplexing use the optional SMX40T Isothermal block. The SMX40T active temperature sensor provides the cold junction temperature sensor, required for Thermocouple measurements. The low thermal EMF of the 4032 minimizes temperature error. Digital Multimeters such as the 2060 and 2064 from *Signametrics* include linearization for various TC types.

As with the *Signametrics* DMMs, these units carry a 30 day no-risk trial period.

The software package included is complete, and does not require any additional drivers or packages. It is not in *Signametrics* interest to constrain users to a short list of S/W packages. Therefore the type of driver provided is universal. It allows these Switches to be controlled by a large number of software environments, including MS Word, Excel, Mat Lab, Visual Basic, C, C++, C#, LabWindows, LabView, ATEasy, Delphi and may other graphical and text based software packages. An added benefit of having no dependencies makes for a fast and easy installation and operation. In less than five minutes you will be controlling these switches.

To preserve the accuracy of a DMM with more than 3-1/2 digits, it is necessary to use an Instrumentation switch.

Specifications

Parameter	4032 (Instrumentation)	4030 (Standard)
Number of differential channels	35	35
Arrangement	Four 8:1 groups	Four 8:1 groups
Scanning W/ on-board Scan List	√	√
Thermal EMF offset	< 1.0 μV	< 10 μV
Maximum Switching DC Voltage	220 V	120 V
Maximum Switching AC Voltage	250 V	120 V
Maximum Switching Current	1 A	1 A
Maximum Sustained Current	1 A	1 A
Typical inter-channel Capacitance	15pf	15pf
Insulation; open contacts	> 1,000 MΩ	> 100 MΩ
Insulation; contacts to coils	> 1,000 MΩ	> 100 MΩ
Insulation; adjacent channels	> 1,000 MΩ	> 100 MΩ
No Load relay Life	10 ⁸	10 ⁷
Loaded Life @ 50Vdc, 0.1A	10 ⁶	10 ⁵
Trigger input	√	√
Trigger output	√	√
Thermocouple Cold Junction Capable	√	
Typical Closure Time	4 ms	12 ms
Typical Release Time [1]	2 ms	5 ms
Minimum Actuation Time [2]	5 ms	15 ms
Actuation Time Range [3]	1ms to 0.85s in 0.25ms steps	1ms to 850ms in 0.25ms steps
Autos can Period Range [3]	1ms to 0.85s in 0.25ms steps	1ms to 850ms in 0.25ms steps
Available Configurations	2-wire, 4-wire, 6-wire, universal, two-groups, four-groups	2-wire, 4-wire, 6-wire, universal, two-groups, four-groups
Available Scan Groups	A, B, C and D	A, B, C and D
Isolated Relay Coil Drive	√	
Active Guard enclosure	√	

- [1] Release time is applicable while in Universal Mode. It is the maximum time it takes for a contact to open.
- [2] Includes amount of time it takes to open any closed relays, and close another.
- [3] Programmable values.

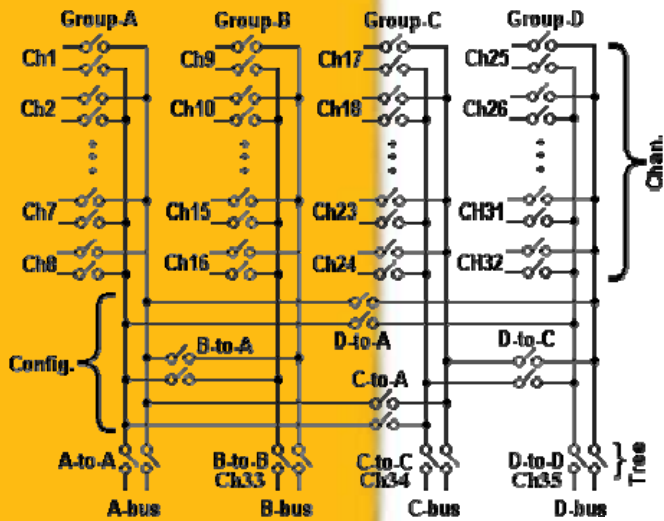

Switch diagram including Channel, Configuration and Tree relays.

Trigger Inputs and Outputs

External Hardware Trigger Input

Input Characteristics

- **Input LED** (nominal 1.7V drop at 1mA) with a series 1kΩ resistor.
- **Input Signal requirements** >2.5 V, < 10 V to activate. < 1V to deactivate.
- **Isolation** Optically isolated from all other circuitry. Common line with Trigger Output.

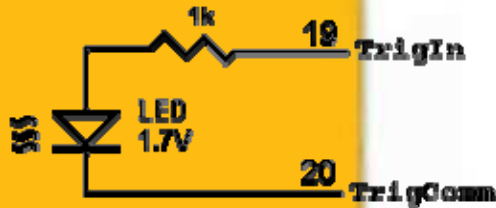

Trigger input equivalent circuit.

External Hardware Trigger Output

Output Characteristics

- **Circuit** Open collector NPN transistor with 0.4V saturation voltage in series with a 1kΩ resistor.
- **Collector Emitter Voltage** < 30 V
- **Output Current** ≤ 4 mA
- **Reverse Voltage** ≤ 7V
- **Isolation** Optically isolated from all other circuitry. Common line with Trigger Input.



Trigger Output Optical Isolator NPN circuit.

PXI Trigger Output (SMX only)

Selectable: PXI Trig1..6 and PXI Star. 5V Logic level

PXI Trigger Input (SMX only)

Selectable: PXI Trig1..6 and PXI Star. 5V Logic level

Configurations

The configuration sets the behavior of each of the sections. It is set by issuing “set configuration” command.

2-Wire Multiplexer Configuration

Issuing “select channel” command while in the 2-Wire configuration, results in the opening the currently closed channel and closure of the selected one. All within a single actuation time, and a break-before-make. Result is a switch behaving as a single 35:1 differential multiplexer. This can be expanded into an almost unlimited number of channels.

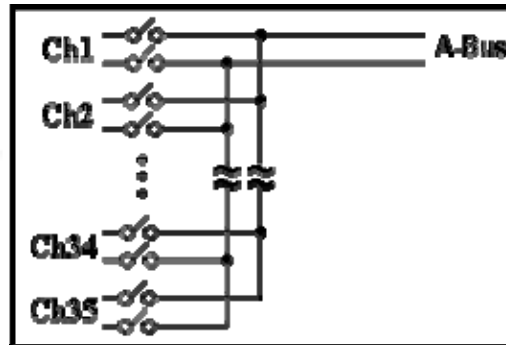

Four Groups Configuration

Each of the four groups acts as independent 8:1 differential multiplexer. Or as four 2-Wire multiplexers as described above.

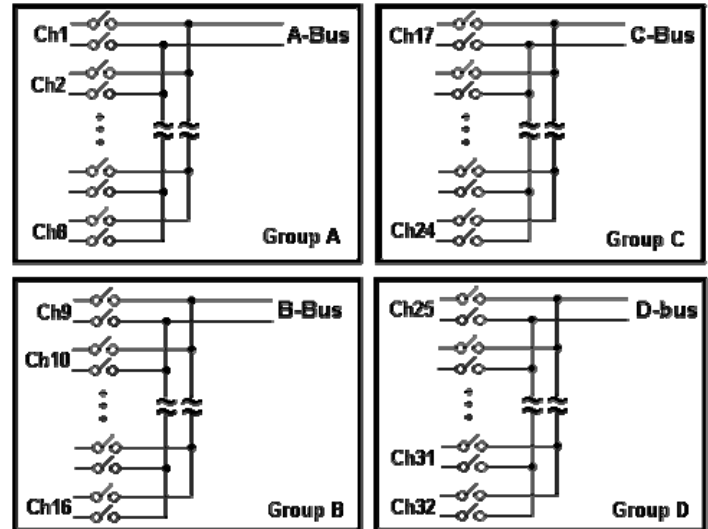

Four Wire Configuration

Issuing "select channel" command while in 4-Wire configuration, opens the currently closed channel relays, and closes the two channel relays associated with the selection. All within a single actuation time, and break-before-make. Result is that four lines are selected simultaneously to complete the 4-Wire channel connection to the A-Bus and C-Bus. 16 channels are available, expandable to an unlimited number of 4-Wire channels.

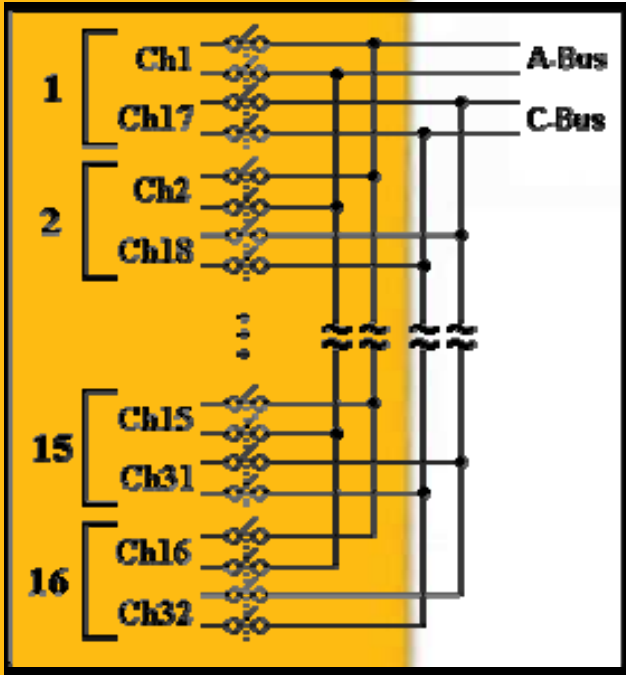

Six Wire Configuration

6-Wire multiplexing is widely used in in-circuit testing. Issuing "select channel" command while in the 6-Wire configuration, results in the opening any currently closed channels and closure of three channel relays corresponding to the selected channel. All within a single actuation time, and a break-before-make. Result is a switch behaving as an 8 channel 6 Wire multiplexer as below. In addition there is one free group of 8 making an 8:1 mux available.

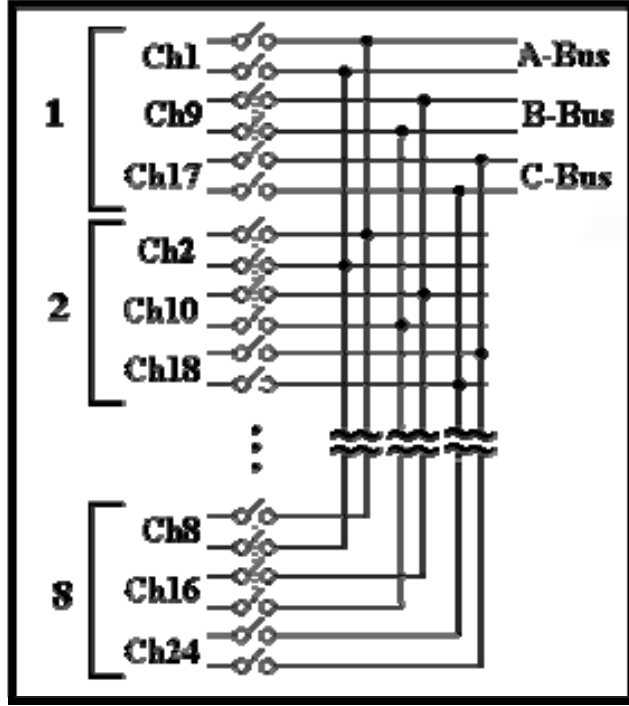

Two Groups Configuration

Each of the two groups acts as independent 16:1 differential multiplexer. Or as two 2-Wire multiplexers as described above.

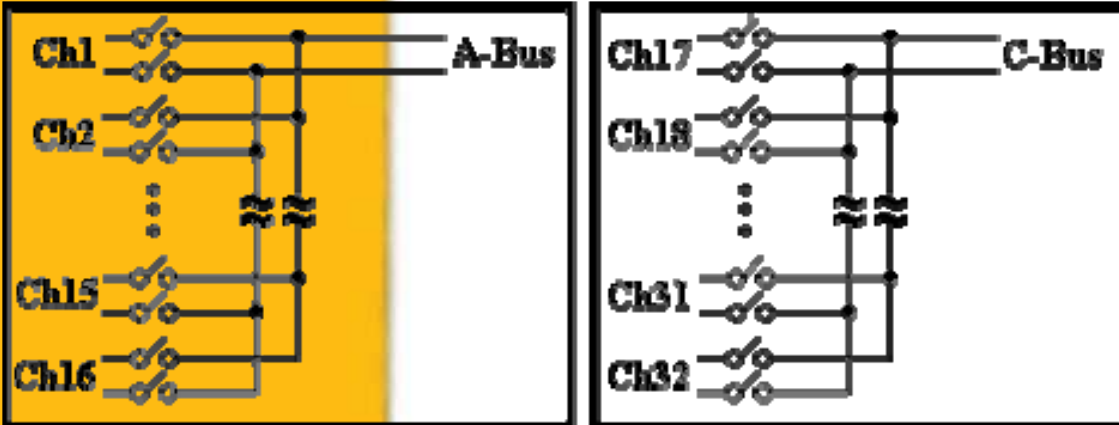

Selector Application

This point-to-point example exemplifies the flexibility of these units. It shows that any one of 68 lines can be selected, making a connection to a single multiplexed line. It makes use of the Universal configuration and requires a short between the Ahi and Clo lines. These lines provide the collector of this selector application. All 68 lines, be it the Lo or Hi terminals of each relay, are accessible.

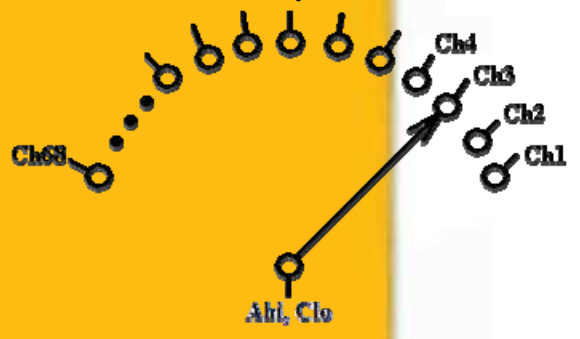

Trigger Output

The trigger output signal may be used to synchronize multiple switches and also trigger another device such as DMM to make a measurement after a selected channel is fully settled. It can be enabled or disabled, set to an active high or low.

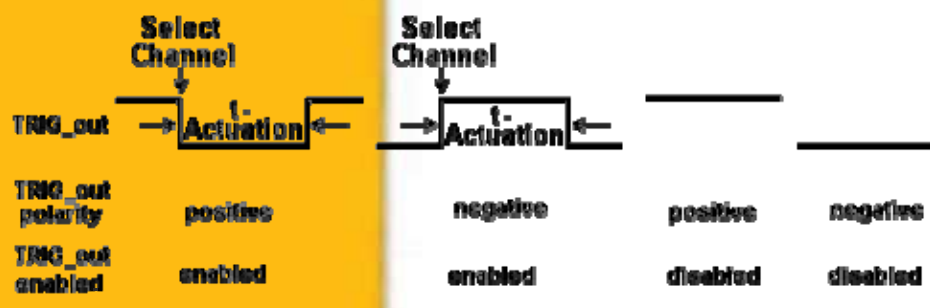

Scanning Operation

There are two Scan operations. Both use an on-board Scan List. Auto Scan operation may be initiated by an external event such as a Trigger input, or by software command. A sequence of channel switching is followed in accordance with an on-board Scan List. Both **t-Step** and **t-Actuation** values are under software control.

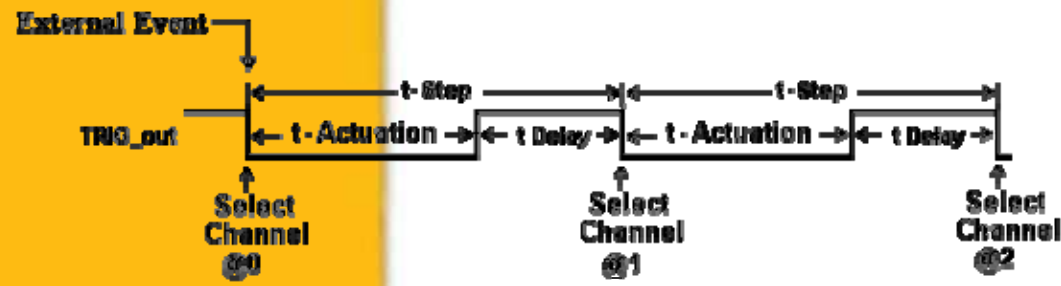

The Channel numbers to be scanned are placed in the on-board Scan List memory. The scan sequence may include channels from multiple 4030 and 4032 units.

The **Single Step** Scanning operation is an additional method, in which switching and stepping through the scan list occurs as a result of a software command, SCANStep(). This helps debug and verify a switching system.

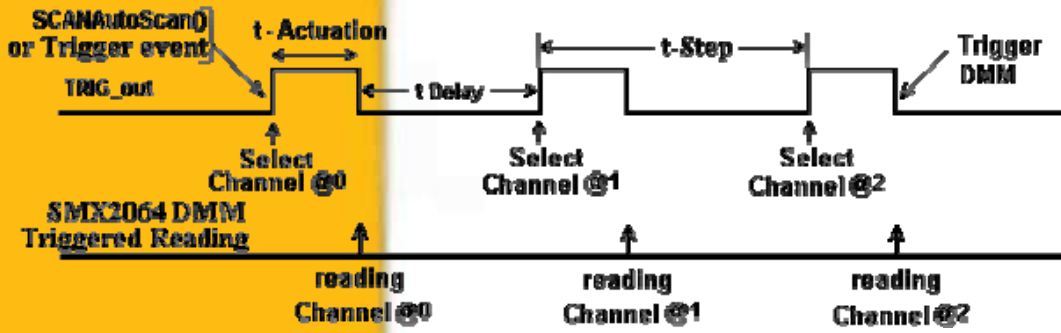

A 2064 class DMM and a 4032 switch can operate independently. A trigger event or a software command initiates the scan and measure process. The 4032 selects a channel from the Scan List, triggers the DMM to take a measurement, and repeats this process until the list is exhausted. No computer intervention is necessary.

Scan List

The Scan list is stored in the on-board memory. It stores the sequence of channels to be switched. Multiple 4030 and 4032 units store the sequence reflecting their participation in the overall scan. The table below depicts the values required to be stored in three SMX4032 units. It shows an example of a channel switching sequence. Note that an entry of zero implies that all channels are to be open, implying that a different card is selected. The sequence starts when an Auto Scan is initiated, be it by an external trigger or a command.

Scanner Number	Scan Table Entries							
	@0	@1	@2	@3	@4	@5	@6	@7
SMX4032 #0	0	0	8	0	0	0	0	1
SMX4032 #1	3	35	0	18	0	0	0	0
SMX4032 #2	0	0	0	0	4	5	6	0
Selected scanner# / Channel	#1 / Ch3	#1 / Ch35	#0 / Ch8	#1 / Ch18	#2 / Ch4	#2 / Ch5	#2 / Ch6	#0 / Ch1

Additional Operations

The **Shorted Channel Locator** operation allows the identification of a shorted input channel. The 4030/32 selects each channel and stops on the first shorted channel detected. It returns the shorted channel number.

Relay contact cleaning is performed by a **Self Cleaning** function. It is accomplished by shaking each relay at varying rates and repeatedly interrupting an internal high voltage source. The result is an effective removal of deposits such as oxidation, polymers and other contaminants from the contact area.

The built in **Integrity test provides** a quick method to identify open, short and excessive actuation times type of failures.

A built in **Bounce Test** provides means to measure the amount of time it takes each relay to close. It measures the time from the application of the coil drive to the time there is no longer variation in the contact resistance.

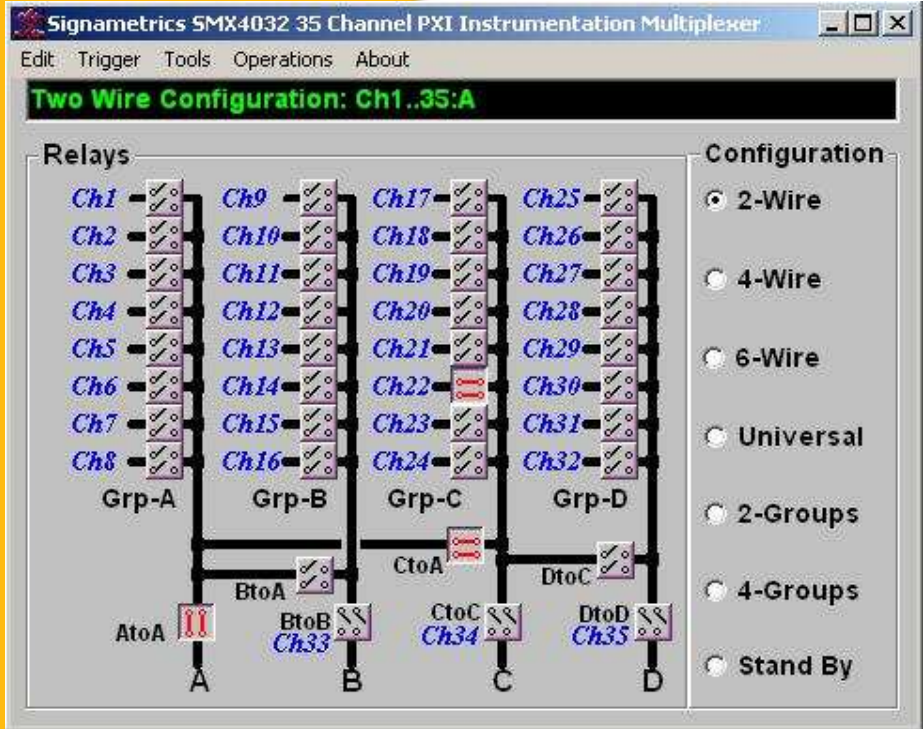

A graphical user interface allows access to most of the features. It is a useful tool to checkout the performance of the unit within minute from installation.



SMX2064 & SMX2044 DMMs and SMX4032 switch.

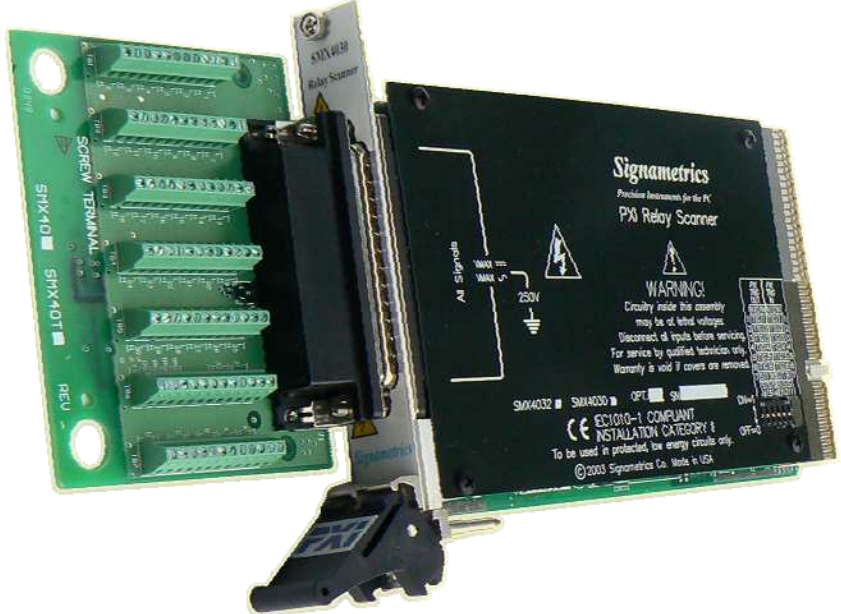

SMX40 Screw terminal unit mounted on an SMX4032



The SMX40L test accessory allows comprehensive testing for each relay of 4030 and 4032 models.

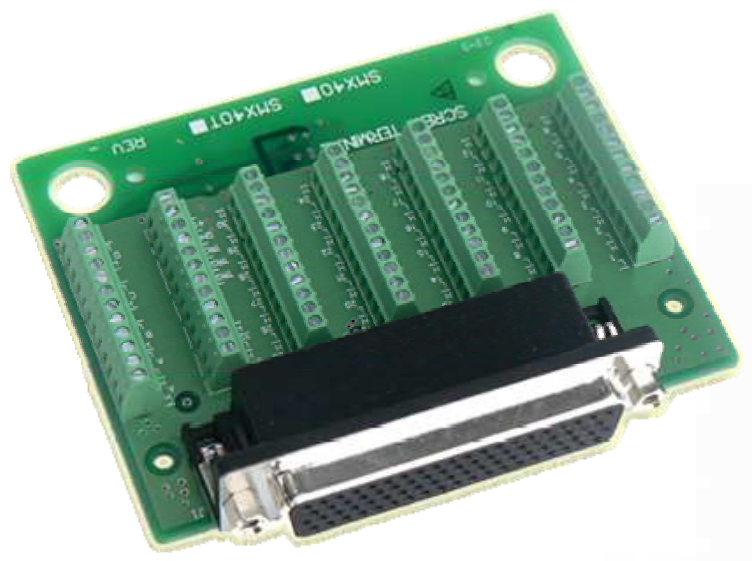

The SMX40 provides a convenient way to make Connections to the 4030 and 4032 models.

Optional accessories

Several accessories are available with the 4030 and 4032 models. These can be purchased directly from Signametrics, or one of its approved distributors or representatives:

- SMX40L - Loop back test module (places a short on all channels).
- SMX40 - Screw terminal module for making quick and easy connection to your application
- SMX40T - Screw terminal module with isothermal block and sensor for Thermocouples.
- SMX40Tool – A screw driver for use with the SMX40 and SMX40T.
- Extended Warranty

Signametrics reserves the rights to make changes to any or all of the above specifications and descriptions without notice, without cause and at any time.