



Agilent L4411A 'Low profile' 6½ Digit Multimeter

Leading the Industry in High-Performance System Test

Product Overview

Agilent L4411A 6½-Digit High- Performance DMM

- 50,000 readings/sec @ 4½ digits direct to PC
- 10,000 readings/sec @ 5½ digits direct to PC
- 1,000 readings/sec @ 6½ digits direct to PC
- Analog level triggering
- Programmable pre/post triggering
- LAN extensions for instruments (LXI), USB & GPIB standard
- 30 PPM 1 year basic DC accuracy
- DCV, ACV, DCI, ACI, 2-wire and 4-wire resistance, frequency, period, and diode test
- Capacitance & temperature measurements
- Expanded measurement ranges



A new standard for modular system DMMs

The L4411A 6½ digit high performance DMM expands Agilent's industry leading offering of LXI system products. For the test system integrator looking for the next generation modular DMM, this new meter offers the industry's best measurement speed and throughput, a reduced size (1 rack unit high), superior measurement performance, and a choice of computer interfaces, including LXI, providing high performance, easy to use, economical I/O. A simple display, including 'latest reading' and LAN address, allows the system integrator to quickly integrate and debug the test system. And finally, the DMM comes with a compatibility mode, requiring little-to-no code change to upgrade your test system with next generation capabilities.

Dramatic system performance

Whether it's raw reading speed or fast system throughput, the L4411A sets a new benchmark in performance. Using a new A/D technology, the L4411A achieves an impressive 50,000 readings a second at 4½ digits, and can stream readings to your computer at this same speed! Transactional I/O (single reading—measurement and PC transfer time) is 3x faster than other popular modular DMMs, significantly enhancing your test throughput. Triggering is fast and precise, with both trigger latency and trigger jitter less than 1 µs, while bus query response is less than 500 µs. ACV measurements are faster as well thanks to a digital measurement technique that additionally improves accuracy at high and low frequencies.



Agilent Technologies

LXI—Class C

LAN Extensions for Instruments (LXI) provides the next generation I/O for system applications requiring high throughput. Transfer rates of over 250,000 readings/sec are attainable ensuring even the most data intensive measurements are fast, without the overhead cost of an instrument mainframe. LXI provides a built-in Graphical Web Interface that allows you to interactively control the DMM without the hassle of programming, making it great for debugging your system. The L4411A DMM is LXI — Class C compliant.

Enhanced measurement capabilities

The L4411A offers temperature and capacitance capabilities in addition to those measurements you have come to expect such as DCV, ACV, DCI, ACI, 2-wire and 4-wire resistance, frequency, period and diode test. You also get offset compensated Ohms, allowing you to accurately measure resistance in the presence of voltages. Measurement ranges have been expanded as well; for example, DC and AC current ranges now go down to 100 μ A, resulting in 100 pA resolution. Real-time math and statistics are included, and a peak-detect capability allows you to capture peaks as short as 20 μ s.

System integration

When deciding on your next system DMM you can't go wrong with the L4411A. Choose from LAN (LXI), USB or GPIB interfaces, all standard on the L4411A, to connect to your computer. The 1U size is perfect for space constrained applications like aerospace/defense depot test. Concerned about the viability of your existing software programs? This new DMM responds to standard

commands for programmable instrumentation (SCPI). Additionally there is a 34401A/E1412A emulation mode to ensure the easiest upgrade possible, virtually eliminating costly software and documentation changes. The autoranging power supply allows you to connect to any input power without selecting input voltages or changing fuses. Agilent's I/O Library Suite ships with the L4411A to help you quickly establish an error-free connection between your PC and instrument. It provides robust instrument control and works with the software development environment you choose.

Companion LXI switch modules

Need a switch to route your signal to the L4411A? Consider Agilent's LXI switch modules. Choose from a 40-channel armature relay multiplexer (L4421A), a dual/quad 4x8 reed relay matrix (L4433A) or a 32-channel Form A/C general purpose relay switch module (L4437A). Additionally, Agilent has LXI DAC, digital I/O and multi-function modules to help complete your test system requirements. All from the leader in LXI instrumentation, Agilent Technologies.

Built to last

Our new DMM was designed to high standards of ruggedness and reliability. From the robust, compact package to careful selection of components and conservative circuit design, this meter is built to last. Calculated mean time between failure (MTBF) is in excess of 100,000 hours. Backed by a 1-year warranty and a worldwide network of service centers, you can buy with confidence.

Go to the web

For the latest information on these or other Agilent DMMs, go to www.agilent.com/find/dmm

DMM dimensions (mm)

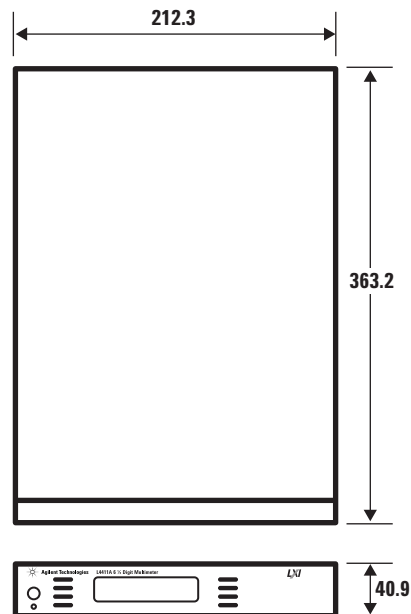

Accuracy Specifications ± (% of reading + % of range) ¹

Function	Range ³	Frequency, test current or burden voltage	24 hour ² Tcal ±1°C	90 day Tcal ±5°C	1 year Tcal ±5°C	Temperature coefficient/°C 0 °C to (Tcal -5°C) (Tcal +5°C) to 55°C
DC voltage	100.0000 mV		0.0030 + 0.0030	0.0040 + 0.0035	0.0050 + 0.0035	0.0005 + 0.0005
	1.000000 V		0.0020 + 0.0006	0.0030 + 0.0007	0.0035 + 0.0007	0.0005 + 0.0001
	10.00000 V		0.0015 + 0.0004	0.0020 + 0.0005	0.0030 + 0.0005	0.0005 + 0.0001
	100.0000 V		0.0020 + 0.0006	0.0035 + 0.0006	0.0040 + 0.0060	0.0005 + 0.0001
	1000.000 V ⁴		0.0020 + 0.0006	0.0035 + 0.0006	0.0040 + 0.0060	0.0005 + 0.0001
True RMS AC voltage⁵	100.0000 mV	3 Hz – 5 Hz	0.50 + 0.02	0.50 + 0.03	0.50 + 0.03	0.010 + 0.003
	to 750.000 V	5 Hz – 10 Hz	0.10 + 0.02	0.10 + 0.03	0.10 + 0.03	0.008 + 0.003
		10 Hz – 20 kHz	0.02 + 0.02	0.04 + 0.02	0.045 + 0.02	0.005 + 0.002
		20 kHz – 50 kHz	0.04 + 0.025	0.08 + 0.025	0.090 + 0.025	0.010 + 0.0025
		50 kHz – 100 kHz	0.10 + 0.040	0.20 + 0.040	0.200 + 0.040	0.020 + 0.0040
	100 kHz – 300 kHz	1.00 + 0.250	1.20 + 0.250	1.200 + 0.250	0.120 + 0.0200	
Resistance⁶	100.0000 Ω	1 mA	0.0030 + 0.0030	0.008 + 0.004	0.010 + 0.004	0.0006 + 0.0005
	1.000000 kΩ	1 mA	0.0020 + 0.0005	0.007 + 0.001	0.010 + 0.001	0.0006 + 0.0001
	10.00000 kΩ	100 μA	0.0020 + 0.0005	0.007 + 0.001	0.010 + 0.001	0.0006 + 0.0001
	100.0000 kΩ	10 μA	0.0020 + 0.0005	0.010 + 0.001	0.012 + 0.001	0.0006 + 0.0001
	1.000000 MΩ	5 μA	0.0020 + 0.0010	0.030 + 0.001	0.040 + 0.001	0.0010 + 0.0002
	10.00000 MΩ	500 nA	0.0100 + 0.0010	0.600 + 0.001	0.800 + 0.001	0.0030 + 0.0004
	100.0000 MΩ	500 nA 10 MΩ	0.200 + 0.001	6.000 + 0.001	8.000 + 0.001	0.1000 + 0.0001
1.000000 GΩ	500 nA 10 MΩ	2.000 + 0.001			1.0000 + 0.0001	
DC current	100.0000 μA	< 0.03 V	0.010 + 0.020	0.040 + 0.025	0.050 + 0.025	0.0020 + 0.0030
	1.000000 mA	< 0.30 V	0.007 + 0.006	0.030 + 0.006	0.050 + 0.006	0.0020 + 0.0005
	10.000000 mA	< 0.03 V	0.007 + 0.020	0.030 + 0.020	0.050 + 0.020	0.0020 + 0.0020
	100.000000 mA	< 0.30 V	0.010 + 0.004	0.030 + 0.005	0.050 + 0.005	0.0020 + 0.0005
	1.000000 A	< 0.80 V	0.050 + 0.006	0.080 + 0.010	0.100 + 0.010	0.0050 + 0.0010
	3.000000 A	< 2.0 V	0.100 + 0.020	0.120 + 0.020	0.150 + 0.020	0.0050 + 0.002
True RMS AC current⁷	100.0000 μA	3 Hz – 5 kHz	0.10 + 0.04	0.10 + 0.04	0.10 + 0.04	0.015 + 0.006
	to 3.000000 A	5 kHz – 10 kHz	0.20 + 0.04	0.20 + 0.04	0.20 + 0.04	0.030 + 0.006
Frequency or period	100 mV to 750 V	3 Hz – 5 Hz	0.070 + 0.000	0.070 + 0.000	0.070 + 0.000	0.005 + 0.000
		5 Hz – 10 Hz	0.040 + 0.000	0.040 + 0.000	0.040 + 0.000	0.005 + 0.000
		10 Hz – 40 Hz	0.020 + 0.000	0.020 + 0.000	0.020 + 0.000	0.001 + 0.000
		40 Hz – 300 kHz	0.005 + 0.000	0.006 + 0.000	0.007 + 0.000	0.001 + 0.000
Capacitance⁸	1.0000 nF	500 nA	0.50 + 0.50	0.50 + 0.50	0.50 + 0.50	0.05 + 0.05
	10.000 nF	1 μA	0.40 + 0.10	0.40 + 0.10	0.40 + 0.10	0.05 + 0.01
	100.00 nF	10 μA	0.40 + 0.10	0.40 + 0.10	0.40 + 0.10	0.01 + 0.01
	1.0000 μF	10 μA	0.40 + 0.10	0.40 + 0.10	0.40 + 0.10	0.01 + 0.01
	10.000 μF	100 μA	0.40 + 0.10	0.40 + 0.10	0.40 + 0.10	0.01 + 0.01
Temperature⁹	RTD	-200 °C to 600 °C	0.06 °C	0.06 °C	0.06 °C	0.003 °C
	Thermistor	-80 °C to 150 °C	0.08 °C	0.08 °C	0.08 °C	0.002 °C
Diode test¹⁰	1.0000 V	1 mA	0.002 + 0.010	0.008 + 0.020	0.010 + 0.020	0.0010 + 0.0020

1. Specifications are for 90 minute warm-up and 100 PLC.

2. Relative to calibration standards.

3. 20% overrange on all ranges, except DCV 1000 V, ACV 750 V, DCI and ACI 3 A ranges.

4. For each additional volt over ± 500 V add 0.02 mV of error.

5. Specifications are for sinewave input > 0.3% of range and > 1 mVrms. Add 30 μV error for frequencies below 1 kHz. 750 VAC range limited to 8 x 10⁷ Volts-Hz. For each additional volt over 300 Vrms add 0.7 mVrms of error.

6. Specifications are for 4-wire resistance measurements, or 2-wire using Math Null. Without Math Null, add 0.2 Ω additional error in 2-wire resistance measurements.

7. Specifications are for sinewave input > 1% of range and > 10 μArms. Frequencies > 5 kHz are typical for 1 A and 3 A ranges.

8. Specifications are for 1-hour warm-up using Math Null. Additional errors may occur for non-film capacitors.

9. For total measurement accuracy, add temperature probe error.

10. Accuracy specifications are for the voltage measured at the input terminals only. 1 mA test current is typical. Variation in the current source will create some variation in the voltage drop across a diode junction.

A-to-D converter noise performance

Integration time (NPLC)	Resolution (ppm of range) ¹	Normal mode rejection (dB) ²	Readings/second ⁴
0.001	30	0	50,000
0.002	15	0	25,000
0.006	6	0	10,000
0.02	3	0	3,000
0.06	1.5	0	1,000
0.2	0.7	0	300
1	0.3	55	60 (50)
2	0.2	110 ³	30 (25)
10	0.1	110 ³	6 (5)
100	0.03	110 ³	0.6 (0.5)

- Resolution is defined as the typical DCV 10 V range RMS noise. Auto-zero on for NPLC ≥ 1 . See manual for additional noise characteristics.
- Normal mode rejection for power line frequency $\pm 0.1\%$.
- For power-line frequency $\pm 1\%$ 75 dB and for $\pm 3\%$ 55 dB.
- Maximum rate with auto-zero off for 60 Hz and (50 Hz) operation.

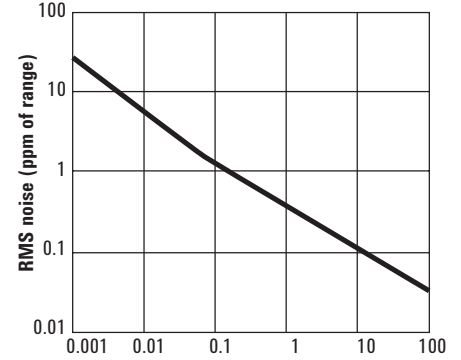

System reading and throughput rates

DMM memory to PC (maximum reading rate out of memory)¹

Drawing – Path B

Reading format	GPIB readings/sec	USB 2.0 readings/sec	LAN (VXI-11) readings/sec	LAN (sockets) readings/sec
ASCII	4,000	8,500	7,000	8,500
32-bit binary	89,000	265,000	110,000	270,000
64-bit binary	47,000	154,000	60,000	160,000

Direct I/O measurements (single reading – measure and I/O time)¹

Drawing – Path C

Function	Resolution (NPLC)	GPIB msec	USB 2.0 msec	LAN (VXI-11) msec	LAN (sockets) msec	Maximum reading rate into memory or to direct I/O (readings/sec) Drawing—Path A or C
DCV/2-wire resistance	0.001	2.6	2.9	4.6	3.2	50,000
ACV/frequency	Fast filter 1 ms gate	10.0	10.0	10.0	10.0	500

- $\frac{1}{2}$ scale input signal, immediate trigger, trigger delay 0, auto-zero off, auto-range off, no math, null off, 60 Hz line frequency. See manual for performance on other functions.

System performance

Function change (msec) ¹	Range change LAN/GPIB (msec) ²	Auto-range (msec) ³	Maximum external trigger rate	Maximum internal trigger rate	
DCV/2-wire resistance	22	3.9/2.6	7.5	5,000/s	50,000/s
ACV/frequency	37	6.5/6.4	19	500/s	500/s

- Time to change from 2-wire Resistance to this specified function, or DCV to 2-wire resistance using the SCPI "FUNC" command
- Time to change from one range to the next higher range, ≤ 10 V, ≤ 10 M Ω
- Time to automatically change one range and be ready for the new measurement, ≤ 10 V, ≤ 10 M Ω

System reading architecture

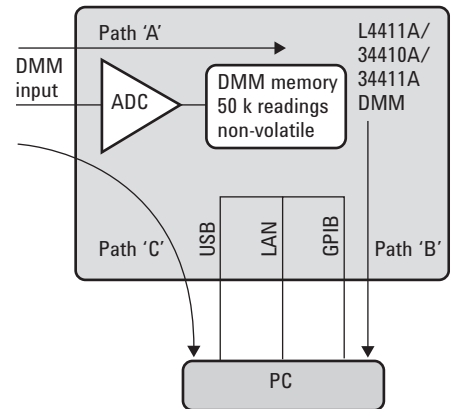

Measurement Characteristics

DC voltage

Measurement method:	Continuously integrating multi-slope IV A/D converter	
Linearity: (10 V range)	0.0002% of reading + 0.0001% of range	
Input resistance:	0.1 V, 1 V, 10 V ranges	10 MΩ or > 10 GΩ (selectable)
	100 V, 1000 V ranges	10 MΩ ±1% (fixed)
Input bias current:	< 50 pA at 25 °C	
Input protection:	1000 V	
DC CMRR:	140 dB ¹	

True RMS AC voltage

Measurement method:	AC-coupled True RMS measurement. Digital sampling with anti-alias filter.
Crest factor:	No additional error for crest factors < 10. Limited by peak input and 300 kHz bandwidth.
Peak input:	300% of range or 1100 V
Overload ranging:	Will select higher range if peak input overload is detected during auto range. Overload is reported in manual ranging.
AC CMR:	70 dB ²
Maximum input:	400 Vdc, 1100 Vpk
Input impedance:	1 MΩ ± 2% in parallel with < 150 pF
Input protection:	750 Vrms all ranges

Resistance

Measurement method:	Selectable 2-wire or 4-wire. Current source referenced to LO input.
Offset compensation:	Selectable on the 100 Ω, 1 kΩ, and 10 kΩ ranges
Max. lead resistance (4-wire):	10% of range per lead for 100 Ω, 1 kΩ. 1 kΩ per lead on all other ranges
Input protection:	1000 V on all ranges

DC current

Current shunt:	200 Ω for 100 μA, 1 mA 2 Ω for 10 mA, 100 mA 0.1 Ω for 1 A, 3 A
Input protection:	3 A, 250 V fuse

True RMS AC current

Measurement method:	AC-coupled true RMS measurement. Directly coupled to the fuse and shunt. Digital sampling with anti-alias filter.
Current shunt:	200 Ω for 100 μA, 1 mA 2 Ω for 10 mA, 100 mA 0.1 Ω for 1 A, 3 A
Maximum input:	The peak value of the DC + AC current must be < 300% of range. The RMS current must be < 3 A including the DC current content.
Input protection:	3 A, 250 V fuse

Frequency and period

Measurement method:	Reciprocal-counting technique. AC-coupled input using the AC voltage measurement function.
Input impedance:	1 MΩ ± 2% in parallel with < 150 pF
Input protection:	750 Vrms all ranges

Capacitance

Measurement method:	Current input with measurement of resulting ramp.
Connection type:	2-wire

Temperature

Thermistor:	2.2 kΩ, 5 kΩ, and 10 kΩ
RTD:	α = 0.00385 R ₀ from 49 Ω to 2.1 kΩ

Diode test

Response time:	300 samples/sec
Continuity threshold:	Fixed at 10 Ω

Operating characteristics

	Maximum readings/second		
	Digits		
Function ³	4.5	5.5	6.5
DCV	50 k	10 k	1 k
2-wire Ω	50 k	10 k	1 k
DCI	50 k	10 k	1 k
Frequency	500	90	10
Period	500	90	10
Filter setting	fast	med	slow
ACV	500	150	50
ACI	500	150	50

Additional specifications

Resolution:	See table on page 4
Overall bandwidth, DCV & DCI:	15 kHz typical @ 20 μs aperture (-3 dB)
Triggering:	Pre/Post, Analog Level, Int/Ext, Pos/Neg
Timebase resolution:	19.9524 μs 0.01% accuracy
Trigger jitter:	2 μs (p-p), 20 μs (p-p) when pre-triggered

1. For 1 kΩ unbalanced in LO lead, ± 500 V peak maximum
2. For 1 kΩ unbalanced in LO lead and < 60 Hz, ± 500 V peak maximum
3. Maximum rate for DCV, DCI, and resistance functions (using zero settling delay, autozero off, manual range)

Spurious-free dynamic range & signal to noise distortion ratio

Function	Range	Spur-free	SNDR
DCV	1 V	-75 dB	60 dB
	10 V ¹	-70 dB	60 dB
	100 V	-75 dB	60 dB

1. 10 V range: 2 V (p-p) <signal< 16 V (p-p)

Triggering and memory

Reading hold sensitivity:	1% of reading
Samples per trigger:	1 to 1,000,000
Trigger delay:	0 to 3600 sec (20 μs step size)
External trigger:	Programmable edge, low-power TTL compatible
Delay:	< 1 μs
Jitter:	< 1 μs
Max rate:	5,000/sec
Min pulse width:	1 μs
Voltmeter complete:	3 V logic output, 2 μs pulse with programmable edge
Nonvolatile memory:	50,000 readings
Volatile memory:	1,000,000 readings
Sample timer:	
Range:	0 to 3600 s (20 μs step sizes)
Jitter:	< 100 ns

General specifications

Power supply:	90 V – 264 V @ 45-66 Hz 90 V – 134 V @ 360 – 440 Hz
Power line frequency:	Automatically sensed at power-on
Power consumption:	50 VA peak (18 W average)
Operating environment:	Full accuracy for 0 °C to 55 °C, 80% R.H. at 40 °C non-condensing
Storage temperature:	-40 °C to 70 °C
Weight:	1.9 kg (4.25 Lbs)
Dimensions:	(W x H x D) 40.9 mm x 212.3 mm x 363.2 mm
Safety:	IEC 61010-1, EN 61010-1, UL 61010-1, CAN/CSA-C22.2 No. 61010-1, refer to Declarations of Conformity for current revisions. Measurement CAT II 300V, CAT I 1000V. Pollution Degree 2
EMC:	IEC 61326, EN 61326, CISPR 11, ICES-001, AS/NZS 2064.1, refer to Declaration of Conformity for current revisions.
Vibration & shock:	MIL-T-28800E, Type III, Class 5 (Sine only)
LXI compliance:	LXI Class C, ver. 1.0
Warranty:	1 year

Ordering Information

Agilent L4411A Multimeter

Accessories included

Test report, power cord, LAN cross-over interface cable.

Product reference CD-ROM (34410-13601):

- Software
 - IntuiLink software
 - IVI-COM driver
 - LabView driver
 - Example programs
- Online documentation
 - Programmer's reference
 - Getting started guide
 - User's guide
 - Service guide
 - Localized manuals

Agilent I/O Libraries CD-ROM (E2094-60003)

Options

- Opt. 001 Front measurement terminals ONLY
- Opt. A6J ANSI Z540 compliant calibration

Agilent accessories

- Y1133A** Measurement & trigger cable kit
- Y1160A** Rack mount kit for L4400A series instruments racks 1 or 2 instruments side-by-side on sliding tray
- 11059A** Kelvin probe set
- 11060A** Surface mount device (SMD) test probes
- 11062A** Kelvin clip set
- 34134A** DC coupled current probe
- 34136A** High voltage probe
- 34138A** Test lead set
- 34171B** Input terminal connector (sold in pairs)
- 34172B** Input calibration short (sold in pairs)
- 34330A** 30 A current shunt
- E2308A** 5 kΩ thermistor probe



Agilent Email Updates

www.agilent.com/find/emailupdates

Get the latest information on the products and applications you select.



www.lxistandard.org

LAN eXtensions for Instruments puts the power of Ethernet and the Web inside your test systems. Agilent is a founding member of the LXI consortium.

Agilent Channel Partners

www.agilent.com/find/channelpartners

Get the best of both worlds: Agilent's measurement expertise and product breadth, combined with channel partner convenience.



Agilent Advantage Services is committed to your success throughout your equipment's lifetime. To keep you competitive, we continually invest in tools and processes that speed up calibration and repair and reduce your cost of ownership. You can also use Infoline Web Services to manage equipment and services more effectively. By sharing our measurement and service expertise, we help you create the products that change our world.

www.agilent.com/find/advantageservices



www.agilent.com/quality

www.agilent.com
www.agilent.com/find/L4411A
www.agilent.com/find/dmm

For more information on Agilent Technologies' products, applications or services, please contact your local Agilent office. The complete list is available at:

www.agilent.com/find/contactus

Americas

Canada	(877) 894 4414
Brazil	(11) 4197 3500
Mexico	01800 5064 800
United States	(800) 829 4444

Asia Pacific

Australia	1 800 629 485
China	800 810 0189
Hong Kong	800 938 693
India	1 800 112 929
Japan	0120 (421) 345
Korea	080 769 0800
Malaysia	1 800 888 848
Singapore	1 800 375 8100
Taiwan	0800 047 866
Other AP Countries	(65) 375 8100

Europe & Middle East

Belgium	32 (0) 2 404 93 40
Denmark	45 70 13 15 15
Finland	358 (0) 10 855 2100
France	0825 010 700*
	*0.125 €/minute
Germany	49 (0) 7031 464 6333
Ireland	1890 924 204
Israel	972-3-9288-504/544
Italy	39 02 92 60 8484
Netherlands	31 (0) 20 547 2111
Spain	34 (91) 631 3300
Sweden	0200-88 22 55
United Kingdom	44 (0) 131 452 0200

For other unlisted Countries:

www.agilent.com/find/contactus

Revised: June 8, 2011

Product specifications and descriptions in this document subject to change without notice.

© Agilent Technologies, Inc. 2011
Published in USA, November 16, 2011
5989-6303EN



Agilent Technologies