

Agilent 2-Port and 4-Port PNA Network Analyzer

N5224A 10 MHz to 43.5 GHz

N5225A 10 MHz to 50 GHz

Data Sheet and
Technical Specifications

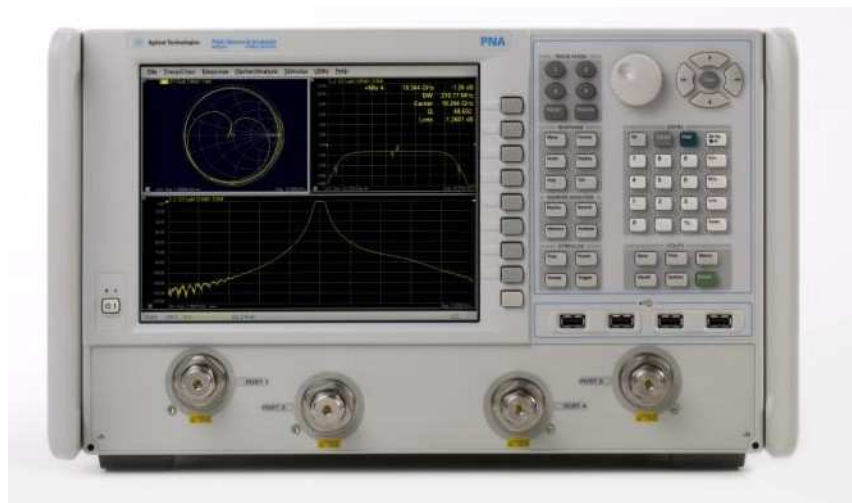

Documentation Warranty

THE MATERIAL CONTAINED IN THIS DOCUMENT IS PROVIDED "AS IS," AND IS SUBJECT TO BEING CHANGED, WITHOUT NOTICE, IN FUTURE EDITIONS. FURTHER, TO THE MAXIMUM EXTENT PERMITTED BY APPLICABLE LAW, AGILENT DISCLAIMS ALL WARRANTIES, EITHER EXPRESS OR IMPLIED WITH REGARD TO THIS MANUAL AND ANY INFORMATION CONTAINED HEREIN, INCLUDING BUT NOT LIMITED TO THE IMPLIED WARRANTIES OF MERCHANTABILITY AND FITNESS FOR A PARTICULAR PURPOSE. AGILENT SHALL NOT BE LIABLE FOR ERRORS OR FOR INCIDENTAL OR CONSEQUENTIAL DAMAGES IN CONNECTION WITH THE FURNISHING, USE, OR PERFORMANCE OF THIS DOCUMENT OR ANY INFORMATION CONTAINED HEREIN. SHOULD AGILENT AND THE USER HAVE A SEPARATE WRITTEN AGREEMENT WITH WARRANTY TERMS COVERING THE MATERIAL IN THIS DOCUMENT THAT CONFLICT WITH THESE TERMS, THE WARRANTY TERMS IN THE SEPARATE AGREEMENT WILL CONTROL.

DFARS/Restricted Rights Notice

If software is for use in the performance of a U.S. Government prime contract or subcontract, Software is delivered and licensed as "Commercial computer software" as defined in DFAR 252.227-7014 (June 1995), or as a "commercial item" as defined in FAR 2.101(a) or as "Restricted computer software" as defined in FAR 52.227-19 (June 1987) or any equivalent agency regulation or contract clause. Use, duplication or disclosure of Software is subject to Agilent Technologies' standard commercial license terms, and non-DOD Departments and Agencies of the U.S. Government will receive no greater than Restricted Rights as defined in FAR 52.227-19(c)(1-2) (June 1987). U.S. Government users will receive no greater than Limited Rights as defined in FAR 52.227-14 (June 1987) or DFAR 252.227-7015 (b)(2) (November 1995), as applicable in any technical data.

Documentation Warranty	2
DFARS/Restricted Rights Notice	2
Definitions	5
Corrected System Performance	6
System Dynamic Range and Receiver Dynamic Range	6
Table 1a. System Dynamic Range and Receiver Dynamic Range, N5224A, Option 200, 400.....	7
Table 1b. System Dynamic Range and Receiver Dynamic Range, N5225A, Option 200, 400.....	8
Table 2. System Dynamic Range at Test Port (dB)	9
Table 3. Extended Dynamic Range at Direct Receiver Access Input (dB) - Specification	10
N5224A and N5225A Corrected System Performance, All Options.....	11
Table 4a. N5224A and N5225A with 85056A Calibration Kit	11
Table 4b. N5224A and N5225A with N4693A 2-Port Electronic Calibration Module	13
Uncorrected System Performance	15
Table 5a. Error Terms (dB), All Ports, All Options - Specifications	15
Table 5b. Error Terms (dB), All Ports, All Options - Typical	16
Test Port Output	17
Table 6. Frequency Information, All Options	17
Table 7a. Maximum Leveled Power (dBm), All Ports - Specification	17
Table 7b. Maximum Leveled Power (dBm), All Ports - Typical	18
Table 8. Power Level Accuracy (dB), All Options	18
Table 9a. Power Level Linearity (dB), All Options - Specification.....	19
Table 9b. Power Level Linearity (dB), All Options - Specification	19
Table 10a. Power Sweep Range (dB), All Ports - Specification	19
Table 10b. N5224 and N5225A Power Sweep Range (dB), All Ports - Typical	20
Table 11. Nominal (Preset) Power (dBm).....	20
Table 12. Power Resolution and Maximum/Minimum Settable Power, All Models and Options ..	20
Table 13. 2 nd and 3 rd Harmonics at Max Specified Power (dBc) All Options - Typical	21
Table 14. Non-Harmonic Spurs at Nominal Power (dBc), All Models and Options - Typical	21
Table 15. Phase Noise (dBc/Hz), All Options - Typical	21
Test Port Input	22
Table 16. Test Port Noise Floor (dBm) @ 10 Hz IFBW, All Options	22
Table 17. Direct Receiver Access Input Noise Floor (dBm), Option 201, 217, 219, 401, 417, 419 ..	23
Table 18a. 0.1 dB Receiver Compression at Test Port (dBm), Option 201, 217, 219, 401, 417, 419 - Typical	23
Table 18b. Receiver Compression at Test Power - Specification.....	24
Table 19. Trace Noise Magnitude (dB rms).....	24
Table 20. Trace Noise Phase (deg rms).....	25
Table 21. Reference Level Magnitude, All Models and Options - Specification	25
Table 22. Stability, All Options - Typical	25
Table 23. Damage Input Level, All ports	25

Dynamic Accuracy	26
Table 24. N5224A and N5225A Dynamic Accuracy	26
Table 25. Group Delay - Typical	29
General Information	30
Table 26. Miscellaneous Information	30
Table 27. Front Panel Information, All Options	30
Table 28. Rear Panel Information, All Options	31
Table 29. Analyzer Dimensions and Weight	35
Regulatory and Environmental Information	35
Measurement Throughput Summary	36
Table 30a. Typical Cycle Time (ms) for Measurement Completion, All Models and Options	36
Table 30b. N5221A Typical Cycle Time (ms) for Full-Span Measurement Completion	37
Table 30c. N5222A Typical Cycle Time (ms) for Full-Span Measurement Completion	37
Table 31. Cycle Time vs. IF Bandwidth - Typical	38
Table 32. Cycle Time vs. Number of Points - Typical	39
Table 33. Data Transfer Time (ms) - Typical	40
Specifications: Front-Panel Jumpers	41
Table 34. Measurement Receiver Inputs (dBm) - Typical	41
Table 35. Reference Receiver Inputs and Reference Source Outputs (dBm) - Typical	42
Table 36. Reference Receiver Inputs and Reference Receiver Outputs (dBm) - Typical	43
Table 37. Source Outputs (dBm) - Typical	44
Table 38. Coupler Inputs (dB) - Typical	45
Table 39. Damage Level - Typical	45
Test Set Block Diagrams	46
N5224A and N5225A Option 200 (2-port base model)	46
N5224A and N5225A Option 201	46
N5224A and N5225A Option 217	47
N5224A and N5225A Option 219	47
N5224A and N5225A Option 400 (4-port base model)	48
N5224A and N5225A Option 401	48
N5224A and N5225A Option 417	49
N5224A and N5225A Option 419	49
Receiver Block Diagram	50

This is a complete list of the technical specifications for the N5224A and N5225A PNA network analyzers with the following options:

2-Port Models

Option 200 - 2-port base model with standard test set.

Option 201 - To base model, adds front-panel jumpers and R1 receiver switch.

Option 217 - To base model, adds front-panel jumpers, R1 receiver switch, and source and receiver attenuators (extended power range).

Option 219 - To base model, adds front-panel jumpers, R1 receiver switch, source and receiver attenuators (extended power range), and bias-tees.

4-Port Models

Option 400 - 4-port base model with standard test set.

Option 401 - To base model, adds front-panel jumpers and R1 receiver switch.

Option 417 - To base model, adds front-panel jumpers, R1 receiver switch, and source and receiver attenuators (extended power range).

Option 419 - To base model, adds front-panel jumpers, R1 receiver switch, source and receiver attenuators (extended power range), and bias-tees.

See block diagrams for all models and options beginning on page 46.

Definitions

All specifications and characteristics apply over a 25 °C ±5 °C range (unless otherwise stated) and 90 minutes after the instrument has been turned on.

Specification (spec.): Warranted performance. Specifications include guardbands to account for the expected statistical performance distribution, measurement uncertainties, and changes in performance due to environmental conditions.

Characteristic (char.): A performance parameter that the product is expected to meet before it leaves the factory, but that is not verified in the field and is not covered by the product warranty. A characteristic includes the same guardbands as a specification.

Typical (typ.): Expected performance of an average unit which does not include guardbands. It is not covered by the product warranty.

Nominal (nom.): A general, descriptive term that does not imply a level of performance. It is not covered by the product warranty.

Calibration: The process of measuring known standards to characterize a network analyzer's systematic (repeatable) errors.

Corrected (residual): Indicates performance after error correction (calibration). It is determined by the quality of calibration standards and how well "known" they are, plus system repeatability, stability, and noise.

Uncorrected (raw): Indicates instrument performance without error correction. The uncorrected performance affects the stability of a calibration.

Standard: When referring to the analyzer, this includes no options unless noted otherwise.

Notes

This document provides technical specifications for the 85056A and N4693A calibration kits.

Please download our free Uncertainty Calculator from http://www.agilent.com/find/na_calculator to generate the curves for your calibration kit and PNA setup.

Corrected System Performance

The specifications in this section apply for measurements made with the N5224A and N5225A PNA network analyzers with the following conditions:

- 10 Hz IF bandwidth
- No averaging applied to data
- Isolation calibration with an averaging factor of 8

System Dynamic Range and Receiver Dynamic Range

- **System Dynamic Range** is defined as the specified source maximum output power (spec) minus the noise floor (spec).
- **Extended Dynamic Range at Direct Access Input** is defined as the specified source maximum output power (spec) minus the direct receiver access input noise floor (spec).
- **Receiver Dynamic Range** is defined as the test port compression at 0.1 dB (typical) minus the noise floor (typical).

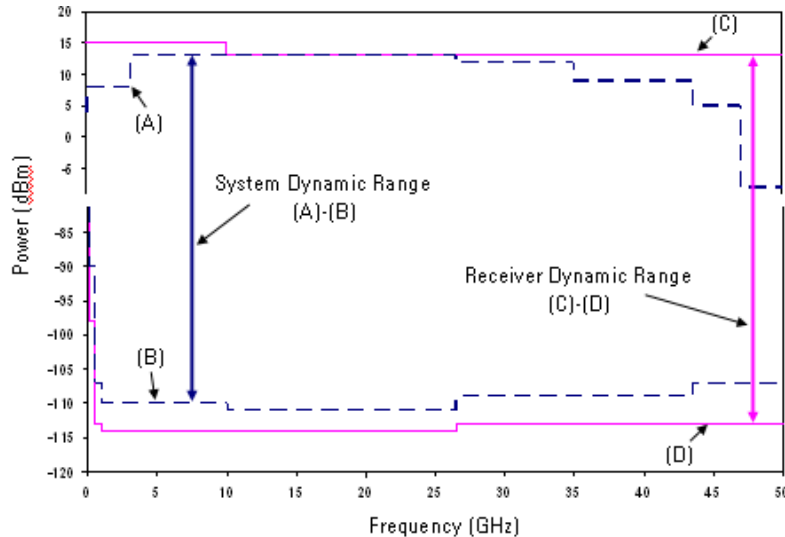

NOTE:

The effective dynamic range must take measurement uncertainties and interfering signals into account. This set-up should only be used when the receiver input will never exceed its maximum receiver input. When the analyzer is in segment sweep mode, it can have predefined frequency segments which will output a higher power level when the extended dynamic range is required (i.e. devices with high insertion loss), and reduced power when the maximum receiver input level will occur (i.e. devices with low insertion loss). The extended range is only available in one-path transmission measurements.

It may typically be degraded at particular frequencies below 500 MHz due to spurious receiver residuals.

Table 1a. System Dynamic Range and Receiver Dynamic Range, N5224A, Option 200, 400

Description	Specification			Typical		
	System Dynamic Range (dB) (A)-(B)	Max Leveled Output Power (dBm) (A)	Test Port Noise Floor (dBm) (B)	Receiver Dynamic Range (dB) (C)-(D)	0.1 dB Compression at Test Port (dBm) (C)	Test Port Noise Floor (dBm) (D)
10 MHz to 50 MHz	82	12	-70	90	15	-75
50 MHz to 100 MHz	98	13	-85	106	15	-91
100 MHz to 250 MHz	108	13	-95	112	12	-100
250 MHz to 500 MHz	115	13	-102	119	12	-107
500 MHz to 1 GHz	119	13	-106	124	12	-112
1 GHz to 10 GHz	127	13	-114	130	12	-118
10 GHz to 26.5 GHz	127	13	-114	132	12	-120
26.5 GHz to 35 GHz	123	13	-110	128	12	-116
35 GHz to 40 GHz	118	10	-108	128	12	-116
40 GHz to 43.5 GHz	118	10	-108	124	10	-114

Table 1b. System Dynamic Range and Receiver Dynamic Range, N5225A, Option 200, 400

Description	Specification			Typical		
	System Dynamic Range (dB) (A)-(B)	Max Leveled Output Power (dBm) (A)	Test Port Noise Floor (dBm) (B)	Receiver Dynamic Range (dB) (C)-(D)	0.1 dB Compression at Test Port (dBm) (C)	Test Port Noise Floor (dBm) (D)
10 MHz to 50 MHz	82	12	-70	90	15	-75
50 MHz to 100 MHz	98	13	-85	106	15	-91
100 MHz to 250 MHz	108	13	-95	112	12	-100
250 MHz to 500 MHz	115	13	-102	119	12	-107
500 MHz to 1 GHz	119	13	-106	124	12	-112
1 GHz to 10 GHz	127	13	-114	130	12	-118
10 GHz to 26.5 GHz	127	13	-114	132	12	-120
26.5 GHz to 35 GHz	123	13	-110	128	12	-116
35 GHz to 40 GHz	118	10	-108	128	12	-116
40 GHz to 43.5 GHz	118	10	-108	124	10	-114
43.5 GHz to 47 GHz	115	6	-109	126	10	-116
47 GHz to 50 GHz	107	-2	-109	126	10	-116

Table 2. System Dynamic Range at Test Port (dB)

Description	Specification			Typical		
	Option 200, 400	Option 201, 401	Option 217, 219, 417, 419	Option 200, 400	Option 201, 401	Option 217, 219, 417, 419
10 MHz to 50 MHz	82	82	80	93	93	93
50 MHz to 100 MHz	98	98	96	109	109	109
100 MHz to 250 MHz	108	108	106	118	118	118
250 MHz to 500 MHz	115	115	113	125	125	125
500 MHz to 1 GHz	119	118	117	130	130	130
1 GHz to 2 GHz	127	127	125	137	137	137
2 GHz to 3.2 GHz	127	127	125	136	136	135
3.2 GHz to 10 GHz	127	127	125	138	138	138
10 GHz to 13.5 GHz	127	127	125	138	138	137
13.5 GHz to 16 GHz	127	127	125	140	139	138
16 GHz to 20 GHz	127	127	124	138	138	137
20 GHz to 24 GHz	127	127	124	138	138	136
24 GHz to 26.5 GHz	127	127	124	138	137	135
26.5 GHz to 30 GHz	123	122	119	133	132	130
30 GHz to 32 GHz	123	121	117	134	133	130
32 GHz to 35 GHz	123	122	119	134	133	130
35 GHz to 43.5 GHz	118	117	112	129	128	125
43.5 GHz to 47 GHz	115	114	108	128	126	123
47 GHz to 50 GHz	107	104	98	124	121	120

Table 3. Extended Dynamic Range at Direct Receiver Access Input (dB) - Specification

Description	Option 201, 401	Option 217, 219, 417, 419
10 MHz to 50 MHz	117	115
50 MHz to 100 MHz	118	116
100 MHz to 250 MHz	120	118
250 MHz to 500 MHz	127	125
500 MHz to 1 GHz	130	129
1 GHz to 10 GHz	139	137
10 GHz to 20 GHz	139	136
20 GHz to 26.5 GHz	137	134
26.5 GHz to 30 GHz	132	129
30 GHz to 32 GHz	131	127
32 GHz to 35 GHz	132	129
35 GHz to 40 GHz	127	122
40 GHz to 43.5 GHz	125	120
43.5 GHz to 47 GHz	122	116
47 GHz to 50 GHz	112	106

N5224A and N5225A Corrected System Performance, All Options

Note: For any S_{ii} reflection measurement:

- $S_{jj} = 0$.

For any S_{ij} transmission measurement:

- $S_{ji} = S_{ij}$ when $S_{ij} \leq 1$
- $S_{ji} = 1/S_{ij}$ when $S_{ij} > 1$
- $S_{kk} = 0$ for all k

Applies to the N5224A/5A Option 200, 201, 217, 219, 400, 401, 417 or 419 analyzers, 85133F flexible test port cable set, and a full 2-port calibration. Also applies to the following condition:

Environmental temperature $23^\circ \pm 3^\circ \text{C}$, with $< 1^\circ \text{C}$ deviation from calibration temperature

Table 4a. N5224A and N5225A with 85056A Calibration Kit

Description	Specification (dB)						
	10 MHz to 50 MHz	50 MHz to 2 GHz	2 GHz to 10 GHz	10 GHz to 20 GHz	20 GHz to 30 GHz	30 GHz to 40 GHz	40 GHz to 50 GHz
Directivity	42	42	42	42	38	38	36
Source Match	41	41	38	38	33	33	31
Load Match	42	42	42	42	37	37	35
Reflection Tracking							
Mag	0.001	0.001	0.008	0.008	0.020	0.020	0.027
Phase (degree)	0.009	0.009	0.054	0.054	0.133	0.133	0.180
Transmission Tracking							
Mag	0.045	0.020	0.036	0.051	0.123	0.123	0.162
Phase (degree)	0.300	0.135	0.236	0.337	0.811	0.811	1.068

Transmission Uncertainty, All Options

Magnitude

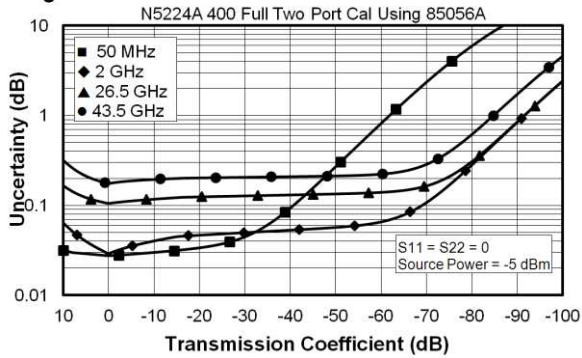

Phase

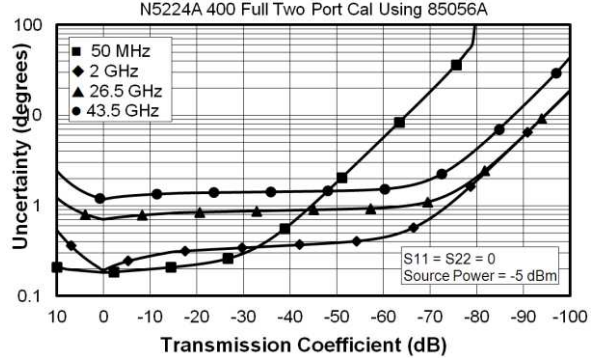

Magnitude

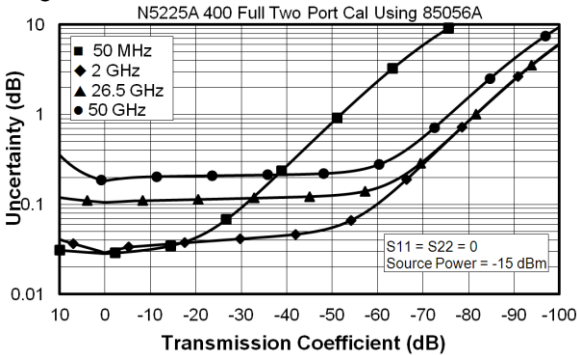

Phase

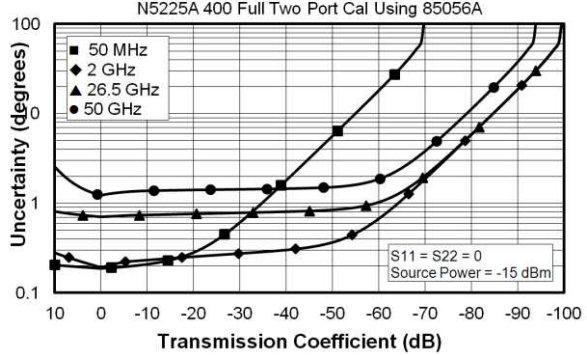

Reflection Uncertainty, All Options

Magnitude

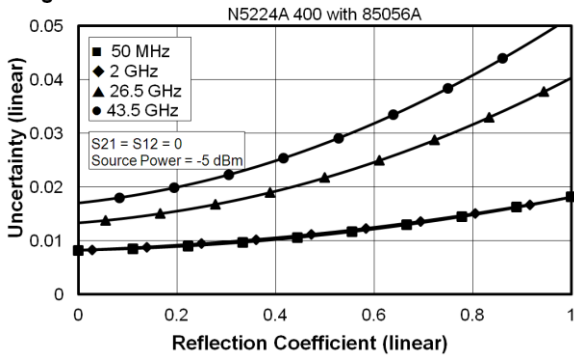

Phase

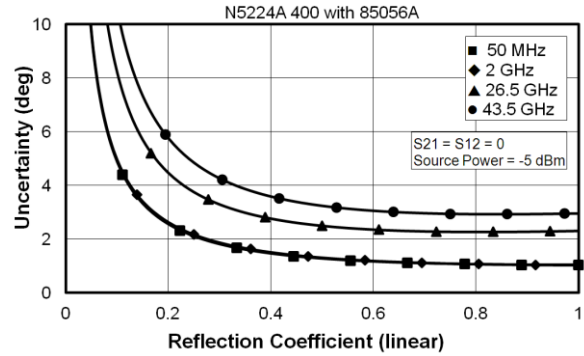

Magnitude

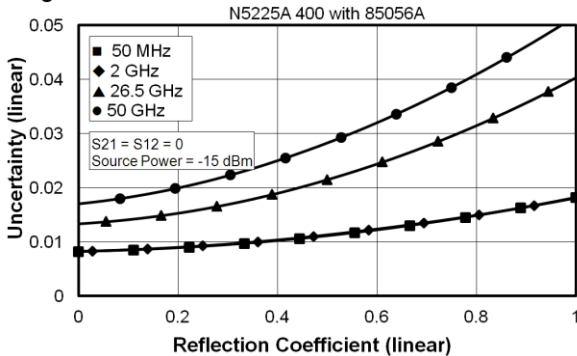

Phase

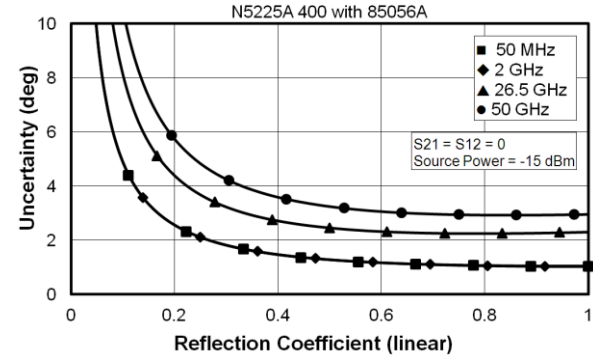
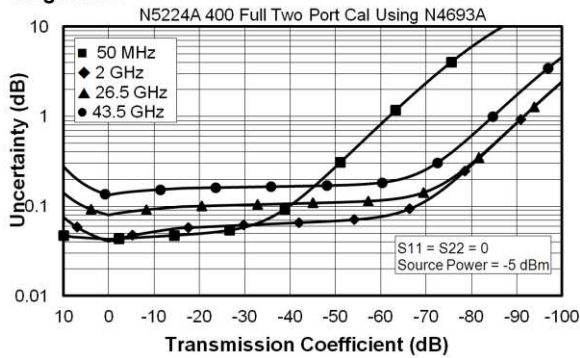

Table 4b. N5224A and N5225A with N4693A 2-Port Electronic Calibration Module

Description	Specification (dB)						
	10 MHz to 50 MHz	50 MHz to 2 GHz	2 GHz to 10 GHz	10 GHz to 20 GHz	20 GHz to 30 GHz	30 GHz to 40 GHz	40 GHz to 50 GHz
Directivity	32	55	49	49	45	43	41
Source Match	25	46	42	42	37	35	30
Load Match	25	45	41	41	36	34	29
Reflection Tracking							
Mag	0.050	0.030	0.040	0.040	0.050	0.060	0.080
Phase (degree)	0.330	0.198	0.264	0.264	0.330	0.396	0.528
Transmission Tracking							
Mag	0.118	0.032	0.047	0.050	0.069	0.084	0.110
Phase (degree)	0.781	0.214	0.309	0.328	0.457	0.556	0.729

Transmission Uncertainty, All Options

Magnitude



Phase

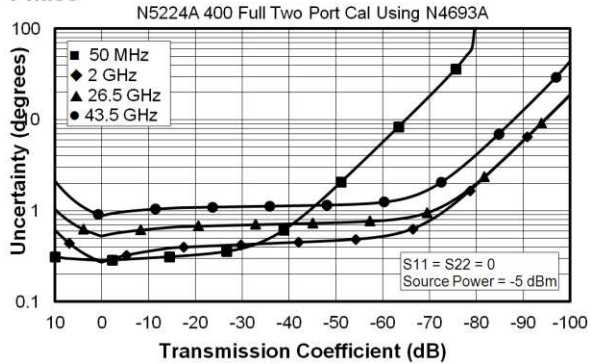

Magnitude

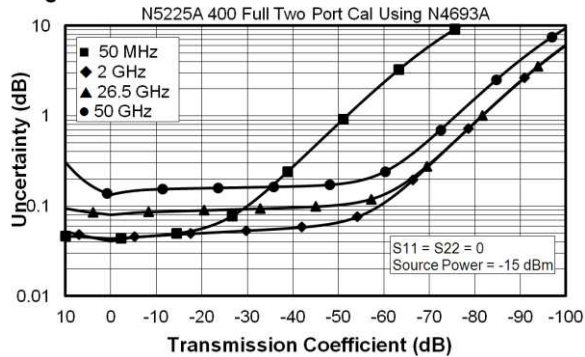

Phase

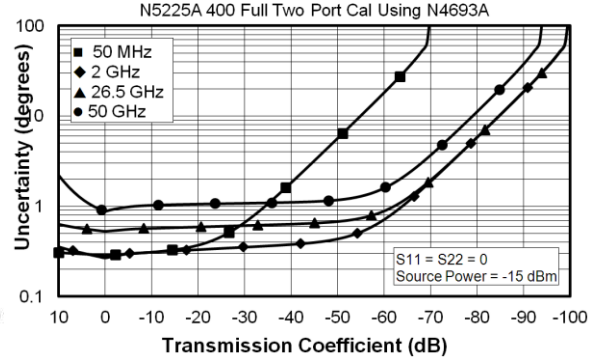

Reflection Uncertainty, All Options

Magnitude

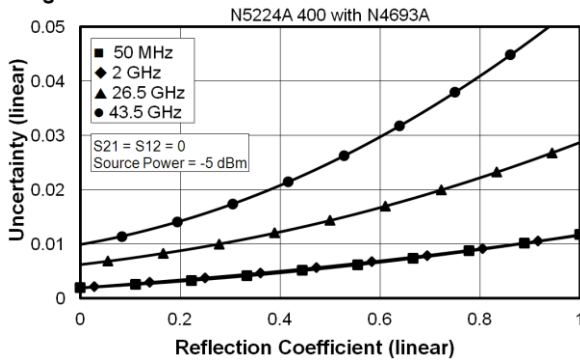

Phase

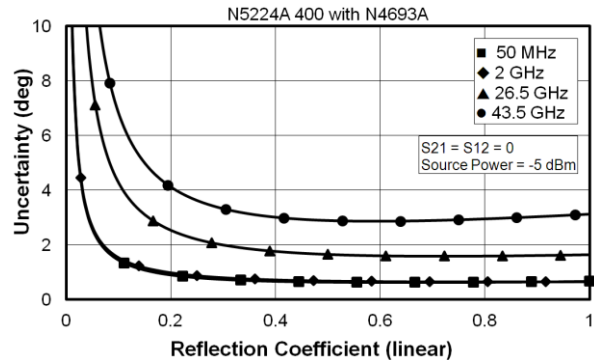

Magnitude

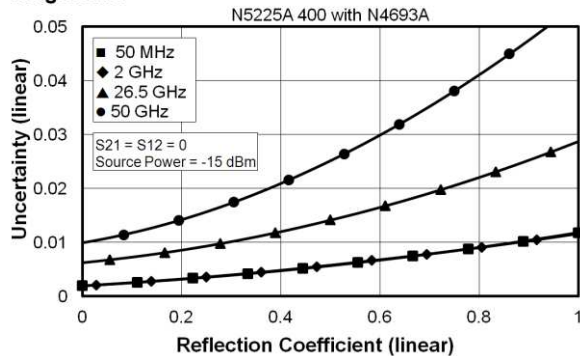

Phase

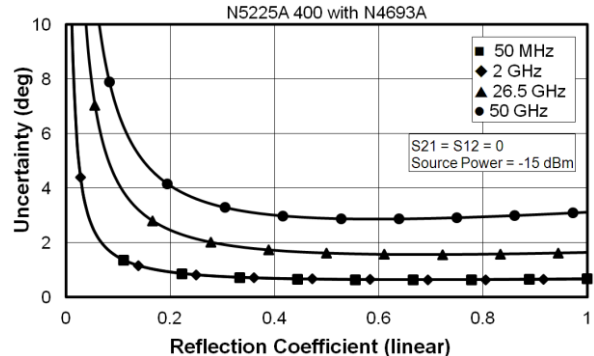

Uncorrected System Performance

Specifications apply to following conditions:

- Over environmental temperature of 25 °C ±5 °C, with less than 1°C variation from the calibration temperature.
- Cable loss not included in Transmission Tracking.
- Crosstalk measurement conditions: normalized to a thru, measured with shorts on all ports, 10 Hz IF bandwidth, averaging factor of 8, alternate mode, source power set to the specified maximum power.

Table 5a. Error Terms (dB), All Ports, All Options - Specifications

Description	Directivity	Source Match	Load Match	Transmission Tracking	Reflection Tracking	Crosstalk
10 MHz to 50 MHz	18	10	10	--	--	--
50 MHz to 200 MHz	22	21	19	--	--	--
200 MHz to 500 MHz	24	21	18	--	--	--
500 MHz to 3.2 GHz	25	18	16	--	--	--
3.2 GHz to 10 GHz	22	16	13	--	--	--
10 GHz to 20 GHz	18	13	11	--	--	--
13.5 GHz to 20 GHz	18	13	10	--	--	--
20 GHz to 26.5 GHz	16	12	10	--	--	--
26.5 GHz to 43.5 GHz	16	8	8	--	--	--
43.5 GHz to 50 GHz	15	7	8	--	--	--

Table 5b. Error Terms (dB), All Ports, All Options - Typical

Description	Directivity	Source Match	Load Match	Transmission Tracking	Reflection Tracking	Crosstalk
10 MHz to 50 MHz	21	15	15	+/- 1.0	+/- 0.7	-82
50 MHz to 200 MHz	28	31	26	+/- 1.0	+/- 0.7	-85
200 MHz to 500 MHz	33	29	24	+/- 1.0	+/- 0.7	-110
500 MHz to 3.2 GHz	30	25	20	+/- 1.0	+/- 0.7	-120
3.2 GHz to 10 GHz	25	22	17	+/- 1.0	+/- 0.7	-120
10 GHz to 13.5 GHz	23	21	15	+/- 1.0	+/- 0.7	-120
13.5 GHz to 16 GHz	20	20	14	+/- 1.0	+/- 0.7	-120
16 GHz to 20 GHz	19	18	16	+/- 1.0	+/- 0.7	-120
20 GHz to 24 GHz	20	17	14	+/- 1.0	+/- 0.7	-120
24 GHz to 26.5 GHz	21	17	15	+/- 1.0	+/- 0.7	-120
26.5 GHz to 35 GHz	19	15	13	+/- 1.0	+/- 0.7	-120
35 GHz to 43.5 GHz	19	15	13	+/- 1.0	+/- 0.7	-115
43.5 GHz to 46 GHz	19	14	14	+/- 1.0	+/- 0.7	-105
46 GHz to 50 GHz	19	13	13	+/- 1.0	+/- 0.7	-100

Test Port Output

See Block diagrams for all models and option beginning on page 45.

Table 6. Frequency Information, All Options

Description	Specification	Typical
N5224A Frequency Range	10 MHz to 43.5 GHz	--
N5225A Frequency Range	10 MHz to 50 GHz	--
Frequency Resolution	1 Hz	--
Frequency Accuracy	+/- 1 ppm	--
Frequency Stability	--	+/-0.05 ppm, -10° to 70° C ¹ +/-0.1 ppm/yr maximum ²

¹ Assumes no variation in time.

² Assumes no variation in temperature.

Table 7a. Maximum Leveled Power (dBm), All Ports - Specification

Description	Option 200, 400	Option 201, 401	Option 217, 417, 219, 419
10 MHz to 50 MHz	12	12	10
50 MHz to 16 GHz	13	13	11
16 GHz to 26.5 GHz	13	13	10
26.5 GHz to 30 GHz	13	12	9
30 GHz to 32 GHz	13	11	7
32 GHz to 35 GHz	13	12	9
35 GHz to 43.5 GHz	10	9	4
43.5 GHz to 47 GHz	6	5	-1
47 GHz to 50 GHz	-2	-5	-11

Table 7b. Maximum Leveled Power (dBm), All Ports - Typical

Description	Option 200, 400	Option 201, 401	Option 217, 417, 219, 419
10 MHz to 1 GHz	18	18	18
1 GHz to 2 GHz	19	19	19
2 GHz to 3.2 GHz	18	18	17
3.2 GHz to 10 GHz	20	20	20
10 GHz to 13.5 GHz	18	18	17
13.5 GHz to 16 GHz	20	19	18
16 GHz to 20 GHz	18	18	17
20 GHz to 24 GHz	18	18	16
24 GHz to 26.5 GHz	18	17	15
26.5 GHz to 30 GHz	19	18	16
30 GHz to 35 GHz	18	17	14
35 GHz to 43.5 GHz	15	14	11
43.5 GHz to 47 GHz	12	10	7
47 GHz to 50 GHz	8	5	4

Table 8. Power Level Accuracy (dB), All Options

Description	Specification	Typical
10 MHz to 1 GHz	+/- 1.0	+/- 0.4
1 GHz to 3.2 GHz	+/- 1.2	+/- 0.1
3.2 GHz to 13.5 GHz	+/- 1.5	+/- 0.3
13.5 GHz to 20 GHz	+/- 1.5	+/- 0.2
20 GHz to 26.5 GHz	+/- 1.8	+/- 0.2
26.5 GHz to 43.5 GHz	+/- 2.2	+/- 0.3
43.5 GHz to 50 GHz	+/- 3.2	+/- 0.5

Table 9a. Power Level Linearity (dB), All Options - Specification

Description	Port 1 or 3 ¹ -25dBm ≤ P < -20dBm	Port 1 or 3 ¹ -20dBm ≤ P < -15dBm	Port 1 or 3 ¹ P ≥ -15dBm
10 MHz to 50 MHz	+/-2.5	+/-1.5	+/-1.5
50 MHz to 500 MHz	+/-2.0	+/-1.5	+/-1.5
500 MHz to 50 GHz	+/-1.5	+/-1.5	+/-1.5

¹ Either port can be used as the source port.

Table 9b. Power Level Linearity (dB), All Options - Specification

Description	Port 2 or 4 ¹ -25dBm ≤ P < -20dBm	Port 2 or 4 ¹ -20dBm ≤ P < -15dBm	Port 2 or 4 ¹ P ≥ -15dBm
10 MHz to 50 MHz	+/-2.5	+/-1.5	+/-1.5
50 MHz to 3.2 GHz	+/-2.0	+/-1.5	+/-1.5
3.2 GHz to 50 GHz	+/-1.5	+/-1.5	+/-1.5

¹ Either port can be used as the source port.

Table 10a. Power Sweep Range (dB), All Ports - Specification

Description	Option 200, 400	Option 201, 401	Option 217, 219, 417, 419
10 MHz to 50 MHz	37	37	35
50 MHz to 16 GHz	38	38	36
16 GHz to 26.5 GHz	38	38	35
26.5 GHz to 30 GHz	38	37	34
30 GHz to 32 GHz	38	36	32
32 GHz to 35 GHz	38	37	34
35 GHz to 43.5 GHz	35	34	29
43.5 GHz to 47 GHz	31	30	24
47 GHz to 50 GHz	23	20	14

Table 10b. N5224 and N5225A Power Sweep Range (dB), All Ports - Typical

Description	Option 200, 400	Option 201, 401	Option 217, 219, 417, 419
10 MHz to 1 GHz	45	45	45
1 GHz to 2 GHz	46	46	46
2 GHz to 3.2 GHz	45	45	44
3.2 GHz to 10 GHz	47	47	47
10 GHz to 13.5 GHz	45	45	44
13.5 GHz to 16 GHz	47	46	45
16 GHz to 20 GHz	45	45	44
20 GHz to 24 GHz	45	45	43
24 GHz to 26.5 GHz	45	44	42
26.5 GHz to 30 GHz	46	45	43
30 GHz to 35 GHz	45	44	41
35 GHz to 43.5 GHz	42	41	38
43.5 GHz to 47 GHz	39	37	34
47 GHz to 50 GHz	35	32	31

Table 11. Nominal (Preset) Power (dBm)

Description	N5224A	N5225A
Option 200, 201, 400, 401	0	-5
Option 217, 219, 417, 419	-5	-15

Table 12. Power Resolution and Maximum/Minimum Settable Power, All Models and Options

Description	Specification (dB)	Typical (dBm)
Power Resolution	0.01	
Maximum Settable Power	--	30
Minimum Settable Power		
Option 200, 201, 400, 401	--	-30
Option 217, 219, 417, 419	--	-90

Table 13. 2nd and 3rd Harmonics at Max Specified Power (dBc) All Options - Typical

Listed frequency is harmonic frequency; test at max specified power

Description	N5224A	N5225A
20 MHz to 4 GHz	-15	-15
4 GHz to 6 GHz	-18	-18
6 GHz to 24 GHz	-19	-19
24 GHz to 27 GHz	-21	-21
27 GHz to 40.5 GHz	-29	-29
40.5 GHz to 43.5 GHz	-66	-66
43.5 GHz to 50 GHz	--	-66

Table 14. Non-Harmonic Spurs at Nominal Power (dBc), All Models and Options - Typical

Offset frequency = 30 kHz to 5 MHz

Description	Based on 8kHz offset Frac-N	Based on 100kHz offset Frac-N
10 MHz to 500 MHz	-50	-50
500 MHz to 2 GHz	-60	-42
2 GHz to 4 GHz	-57	-45
4 GHz to 8 GHz	-51	-39
8 GHz to 16 GHz	-45	-33
16 GHz to 32 GHz	-39	-27
32 GHz to 50 GHz	-33	-21

Table 15. Phase Noise (dBc/Hz), All Options - Typical

Description	1 kHz Offset	10 kHz Offset	100 kHz Offset	1 MHz Offset
10 MHz to 50 MHz	-100	-95	-95	-120
50 MHz to 1 GHz	-107	-117	-112	-127
1 GHz to 2 GHz	-101	-111	-106	-121
2 GHz to 4 GHz	-95	-105	-100	-115
4 GHz to 8 GHz	-89	-99	-94	-109
8 GHz to 16 GHz	-83	-93	-88	-103
16 GHz to 32 GHz	-77	-87	-82	-97
32 GHz to 50 GHz	-71	-81	-76	-91

Test Port Input

Table 16. Test Port Noise Floor (dBm) @ 10 Hz IFBW, All Options

Total average (rms) noise power calculated as the mean value of a linear magnitude trace expressed in dBm.

May typically be degraded at particular frequencies below 500 MHz due to spurious receiver residuals.

Description	Specification		Typical	
	N5224A	N5225A	N5224A	N5225A
10 MHz to 50 MHz	-70	-70	-75	-75
50 MHz to 100 MHz	-85	-85	-91	-91
100 MHz to 250 MHz	-95	-95	-100	-100
250 MHz to 500 MHz	-102	-102	-107	-107
500 MHz to 1 GHz	-106	-106	-112	-112
1 GHz to 10 GHz	-114	-114	-118	-118
10 GHz to 26.5 GHz	-114	-114	-120	-120
26.5 GHz to 35 GHz	-110	-110	-116	-116
35 GHz to 40 GHz	-108	-108	-116	-116
40 GHz to 43.5 GHz	-108	-108	-114	-114
43.5 GHz to 50 GHz	--	-109	--	-116

Table 17. Direct Receiver Access Input Noise Floor (dBm), Option 201, 217, 219, 401, 417, 419

Total average (rms) noise power calculated as the mean value of a linear magnitude trace expressed in dBm.

May typically be degraded at particular frequencies below 500 MHz due to spurious receiver residuals.

Description	Specification		Typical	
	N5224A	N5225A	N5224A	N5225A
10 MHz to 50 MHz	-105	-105	-119	-119
50 MHz to 100 MHz	-105	-105	-121	-121
100 MHz to 250 MHz	-107	-107	-121	-121
250 MHz to 500 MHz	-114	-114	-128	-128
500 MHz to 1 GHz	-118	-118	-133	-133
1 GHz to 10 GHz	-126	-126	-133	-133
10 GHz to 20 GHz	-126	-126	-135	-135
20 GHz to 26.5 GHz	-124	-124	-134	-134
26.5 GHz to 35 GHz	-120	-120	-130	-130
35 GHz to 40 GHz	-118	-118	-130	-130
40 GHz to 43.5 GHz	-116	-116	-125	-125
43.5 GHz to 50 GHz	--	-117	--	-127

Table 18a. 0.1 dB Receiver Compression at Test Port (dBm), Option 201, 217, 219, 401, 417, 419 - Typical

Description	N5224A	N5225A
10 MHz to 100 MHz	15	15
100 MHz to 40 GHz	12	12
40 GHz to 43.5 GHz	10	10
43.5 GHz to 50 GHz	--	10

Table 18b. Receiver Compression at Test Power - Specification

Description	Test Port Power (dBm)				Receiver Compression	
	Option 200, 400	Option 201, 401	Option 217, 417	Option 219, 419	Magnitude (dB)	Phase (degrees)
10 MHz to 500 MHz ¹	--	--	--	--	--	--
500 MHz to 10 GHz	11	13	11	11	0.15	1.5
10 GHz to 16 GHz	10	13	11	11	0.15	1.5
16 GHz to 20 GHz	10	13	10	10	0.15	1.5
20 GHz to 26.5 GHz	9	13	10	10	0.18	1.5
26.5 GHz to 30 GHz	9	12	9	9	0.18	1.5
30 GHz to 32 GHz	9	11	8	8	0.18	1.5
32 GHz to 35 GHz	9	10	9	9	0.18	1.5
35 GHz to 43.5 GHz	5	9	8	8	0.18	1.5
43.5 GHz to 47 GHz	1	8	8	8	0.2	1.5
47 GHz to 50 GHz	-5	8	8	8	0.2	1.5

¹Test port receiver compression at specified input levels below 500 MHz due to coupler roll off in this frequency range.

Table 19. Trace Noise Magnitude (dB rms)

Ratioed measurement, nominal power at test port.

Description	Specification	Typical		
	1 kHz IFBW	1 kHz IFBW	100 kHz IFBW	600 kHz IFBW
10 MHz to 50 MHz	0.200	0.071	0.667	1.612
50 MHz to 100 MHz	0.020	0.009	0.088	0.209
100 MHz to 500 MHz	0.020	0.004	0.040	0.098
500 MHz to 1 GHz	0.003	0.001	0.009	0.022
1 GHz to 26.5 GHz	0.003	0.001	0.006	0.015
26.5 GHz to 43.5 GHz	0.003	0.001	0.009	0.021
43.5 GHz to 50 GHz	0.004	0.002	0.007	0.018

Table 20. Trace Noise Phase (deg rms)

Ratiod measurement, nominal power at test port.

Description	Specification	Typical		
	1 kHz IFBW	1 kHz IFBW	100 kHz IFBW	600 kHz IFBW
10 MHz to 50 MHz	1.000	0.485	4.681	11.310
50 MHz to 100 MHz	1.000	0.062	0.614	1.456
100 MHz to 500 MHz	0.500	0.029	0.276	0.680
500 MHz to 1 GHz	0.020	0.006	0.061	0.149
1 GHz to 26.5 GHz	0.020	0.008	0.040	0.100
26.5 GHz to 43.5 GHz	0.030	0.014	0.067	0.159
43.5 GHz to 50 GHz	0.030	0.015	0.061	0.142

Table 21. Reference Level Magnitude, All Models and Options - Specification

Description	Magnitude (dB)	Phase (degrees)
Range	+/- 500	+/- 500
Resolution	0.001	0.01

Table 22. Stability, All Options - Typical

Description	Magnitude (dB/°C)	Phase (°/°C)
10 MHz to 50 MHz	0.020	0.200
50 MHz to 3.2 GHz	0.010	0.100
3.2 GHz to 10 GHz	0.010	0.200
10 GHz to 16 GHz	0.010	0.250
16 GHz to 20 GHz	0.015	0.300
20 GHz to 26.5 GHz	0.015	0.400
26.5 GHz to 35 GHz	0.020	0.600
35 GHz to 43.5 GHz	0.020	0.650
43.5 GHz to 47 GHz	0.025	0.700
47 GHz to 50 GHz	0.027	0.750

Table 23. Damage Input Level, All ports

Description	Option 200, 201, 219, 400, 401, 419	Option 217, 417
RF, DC	27 dBm, 40 V	27 dBm, 7 V

Dynamic Accuracy

Dynamic accuracy is verified with the following measurements:

Compression over frequency

IF linearity at a single frequency of 1.998765GHz using a reference level of -20 dBm for an input power range of 0 to -60 dBm. For values below -60 dBm, refer to [“VNA Receiver Dynamic Accuracy Specifications and Uncertainties”](#)

Table 24. N5224A and N5225A Dynamic Accuracy

N5224A/25A Dynamic Accuracy, 10 MHz to 50 MHz - Specification

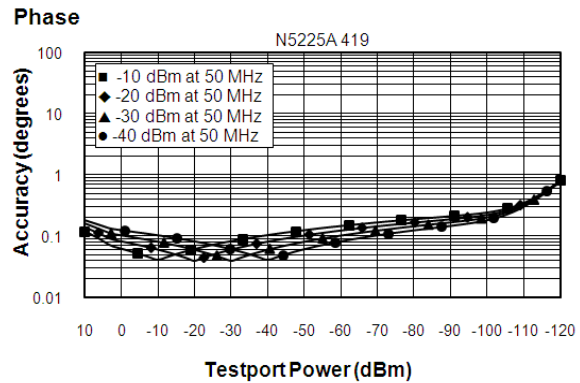
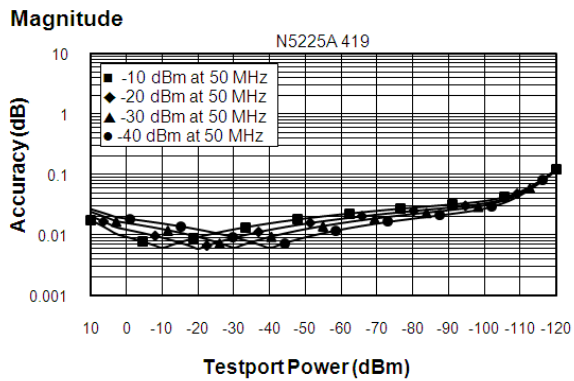

N5224A/25A Dynamic Accuracy, 50 MHz to 500 MHz - Specification

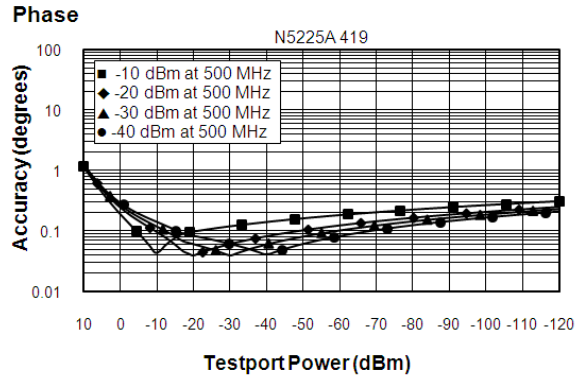
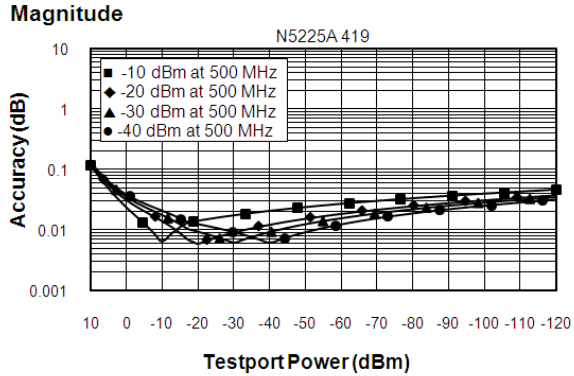

N5224A/25A Dynamic Accuracy, 500 MHz to 1 GHz - Specification

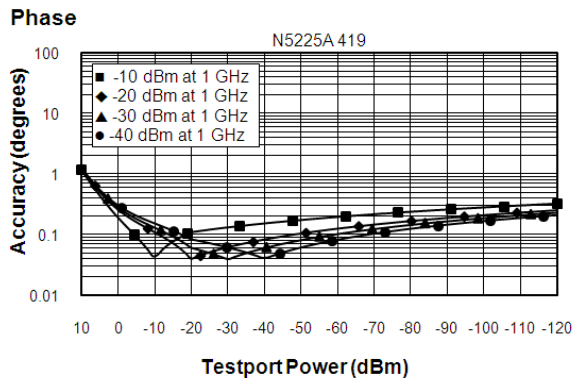
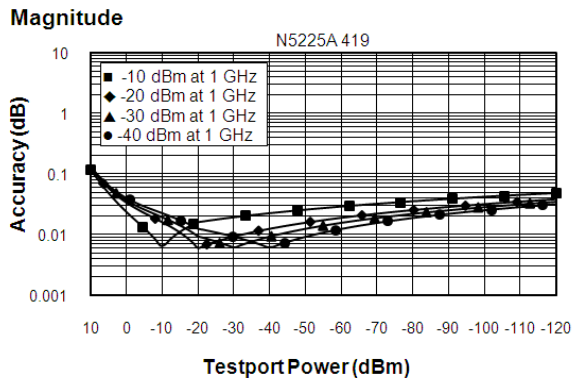

N5224A/25A Dynamic Accuracy, 1 GHz to 2 GHz - Specification

Magnitude

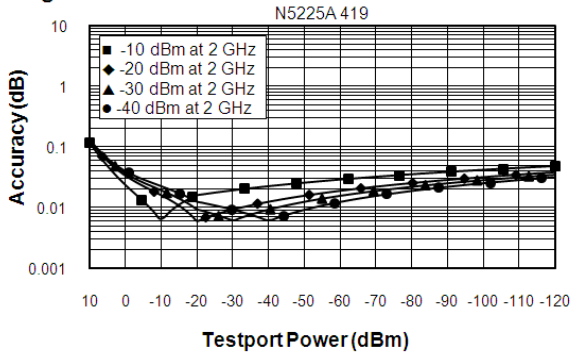

Phase

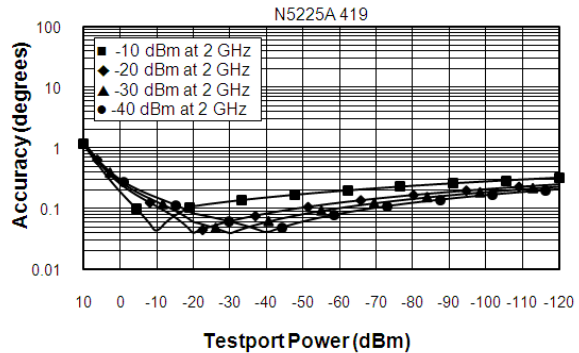

N5224A/25A Dynamic Accuracy, 2 GHz to 20 GHz - Specification

Magnitude

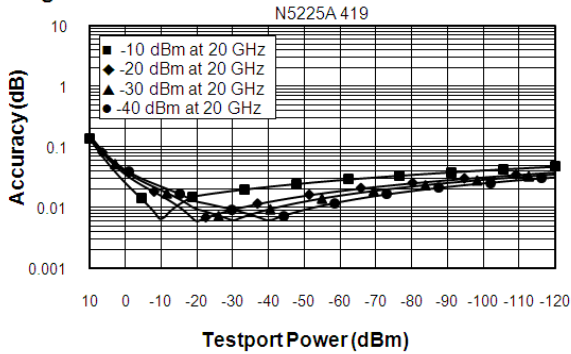

Phase

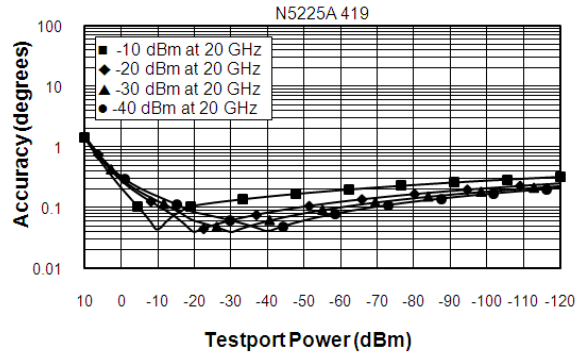

N5224A/25A Dynamic Accuracy, 20 GHz to 26.5 GHz - Specification

Magnitude

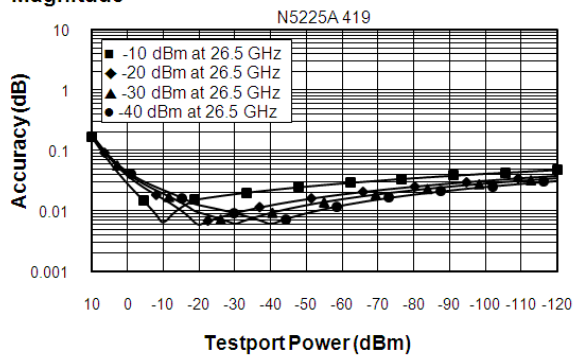

Phase

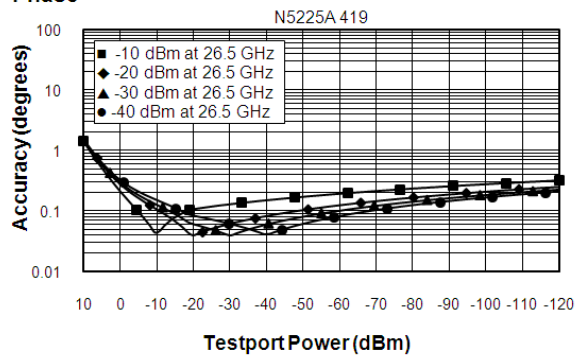

N5224A/25A Dynamic Accuracy, 26.5 GHz to 35 GHz - Specification

Magnitude

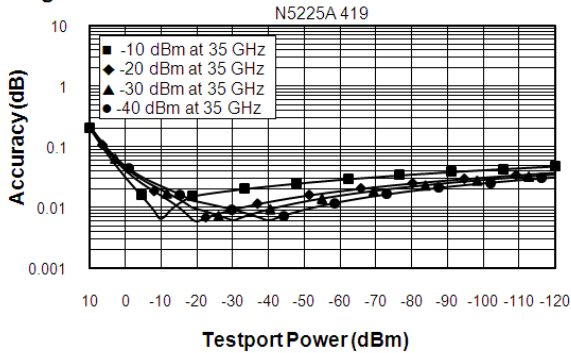

Phase

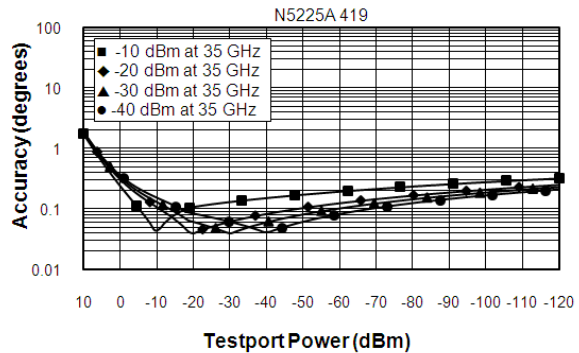

N5224A/25A Dynamic Accuracy, 35 GHz to 40 GHz - Specification

Magnitude

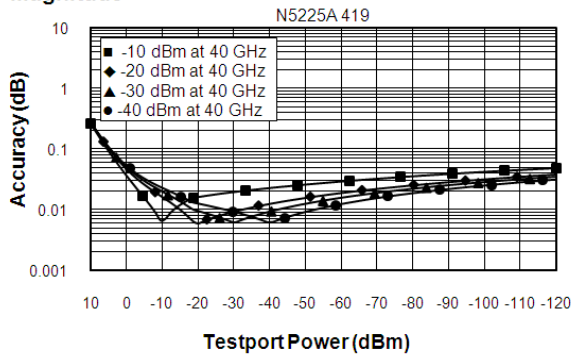

Phase

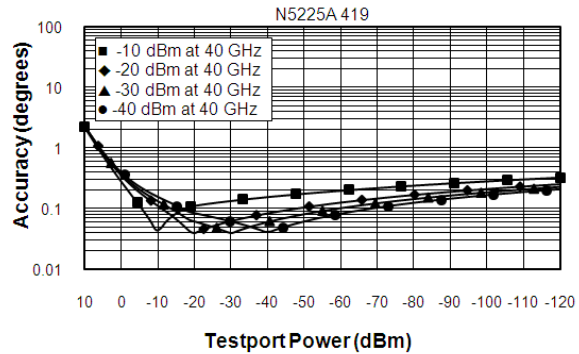

N5224A/25A Dynamic Accuracy, 40 GHz to 50 GHz - Specification

Magnitude

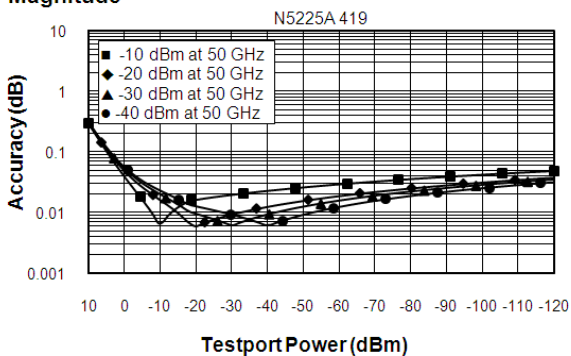

Phase

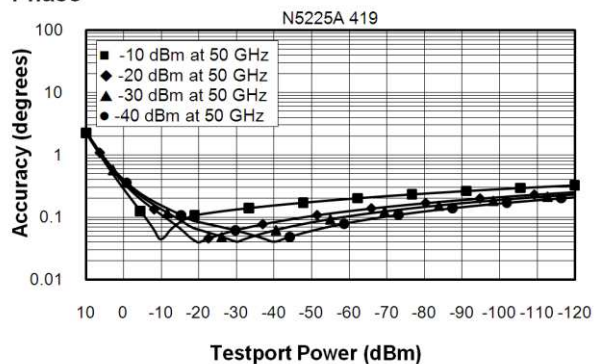

Table 25. Group Delay - Typical

Group delay is computed by measuring the phase change within a specified frequency step (determined by the frequency span and the number of points per sweep). In general, the following formula can be used to determine the accuracy, in seconds, of specific group delay measurement:

$$\pm \text{Phase Accuracy (deg)} / [360 \times \text{Aperture (Hz)}]$$

Depending on the aperture and device length, the phase accuracy used is either incremental phase accuracy or worst-case phase accuracy

Description	Typical Performance
Aperture (selectable)	(frequency span)/(number of points -1)
Maximum Aperture	20% of frequency span
Range	0.5 x (1/minimum aperture)
Maximum Delay	Limited to measuring no more than 180° of phase change within the minimum aperture.)

The following graphs show characteristic group delay accuracy with full 2-port calibration and a 10 Hz IF bandwidth. Insertion loss is assumed to be < 2 dB and electrical length to be ten meters.

For any S_{ij} Group Delay measurement, $S_{ii} = 0$, $S_{ij} = 1$, $S_{ji} = 0$, $S_{kl} = 0$ for all $kl \neq ij$

Group Delay (Typical)

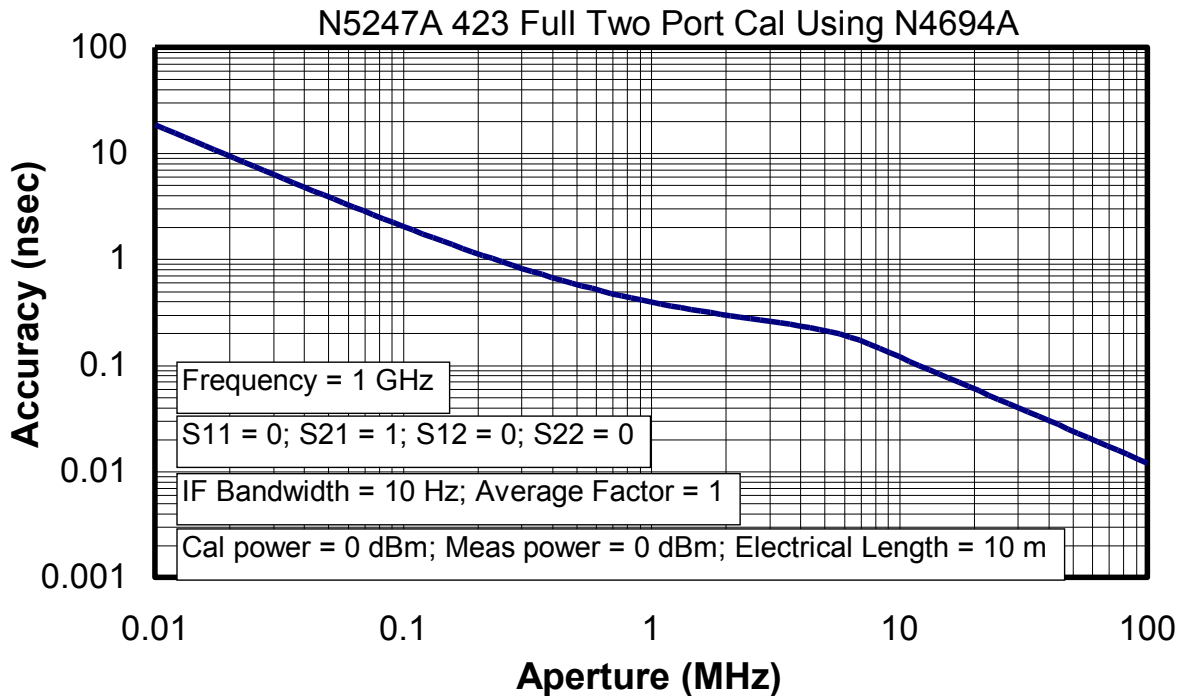

General Information

- [Miscellaneous Information](#)
- [Front Panel](#)
- [Rear Panel](#)
- [Environment and Dimensions](#)

Table 26. Miscellaneous Information

Description	Supplemental Information
System IF Bandwidth Range	1 Hz to 15 MHz, nominal
CPU	Intel 2.0 GHz Core i7. Note: Some instruments may have a different CPU. For the latest information on CPUs and associated hard drives, visit: http://na.tm.agilent.com/pna/hdnumbers.html
LXI	Class C

Table 27. Front Panel Information, All Options

Description	Typical Performance
RF Connectors	
Type	2.4 mm (male), 50 ohm, (nominal)
Center Pin Recession	0.002 in. (characteristic)
USB 2.0 Ports - Master (4 ports)	
Standard	Compatible with USB 2.0
Connector	USB Type-A female
Display	
Size	26.3 cm (10.4 in) diagonal color active matrix LCD; 1024 (horizontal) X 768 (vertical) resolution
Refresh Rate	Vertical 60 Hz; Horizontal 46.08 kHz
Pixels	Any of the following would cause a display to be considered faulty: <ul style="list-style-type: none"> • A complete row or column consists of “stuck” or “dark” pixels. • More than six “stuck on” pixels (but not more than three green) or more than 0.002% of the total pixels are within the LCD specifications. • More than twelve “dark” pixels (but no more than seven of the same color) or more than 0.004% of the total pixels are within the LCD specifications. • Two or more consecutive “stuck on” pixels or three or more consecutive “dark” pixel (but no more than one set of two consecutive dark pixels) • “Stuck on” “dark” pixels are less than 6.5 mm apart (excluding consecutive pixels)

Table 27. (Continued) Front Panel Information, All Options

Description	Typical Performance
Display Range	
Magnitude	+/-2500 dB (at 500 dB/div), max
Phase	+/-2500° (at 500 dB/div), max
Polar	10 pUnits, min 10,000 Units, max
Display Resolution	
Magnitude	0.001 dB/div, min
Phase	0.01°/div, min
Marker Resolution	
Magnitude	0.001 dB, min
Phase	0.01°, min
Polar	10 pUnit, min

Table 28. Rear Panel Information, All Options

Description	Typical Performance
10 MHz Reference In	
Connector	BNC, female
Input Frequency	10 MHz ± 10 ppm
Input Level	-15 dBm to +20 dBm
Input Impedance	200 Ω, nom.
10 MHz Reference Out	
Connector	BNC, female
Output Frequency	10 MHz ± 1 ppm
Signal Type	Sine Wave
Output Level	+10 dBm ± 4 dB into 50 Ω
Output Impedance	50 Ω, nominal
Harmonics	<-40 dBc, typical

Table 28. (Continued) Rear Panel Information, All Options

Description	Typical Performance
External IF Inputs	
Function	Allows use of external IF signals from remote mixers, bypassing the PNA's first converters
Connectors	SMA (female); A, B, C, D, R (4-port); A, B, R1, R2 (2-port)
Input Frequency	
Normal IF path	RF < 53 MHz: IF = 826.446 KHz RF >= 53 MHz: IF = 7.438 MHz
Narrowband IF path	IF = 10.70 MHz
Input Impedance	50 Ω
RF Damage Level	+23 dBm
DC Damage Level	5.5 VDC
0.1 dB Compression Point	
Normal IF path	-9.0 dBm at 7.438 MHz
Narrowband IF path	-17 dBm at 10.70 MHz
Pulse Inputs (IF Gates)	
Function	Internal receiver gates used for point-in-pulse and pulse-profile measurements
Connectors	15-pin mini D-sub
Input Impedance	1 K Ohm
Minimum Pulse Width, Source Modulators	33 ns
Minimum Pulse Width, Receiver Gates	20 ns
DC Damage Level	5.5 VDC
Drive Voltage	0 V (off), +3.3 V (on), nominal
RF Pulse Modulator Input (Source Modulator)	
On/Off Ratio	
10 MHz to 3.2 GHz	-64
3.2 GHz to 50 GHz	-80
Pulse Period	
Minimum	33 ns
Maximum	70 s

Table 28. (Continued) Rear Panel Information, All Options

Description	Typical Performance	
Pulse Outputs		
Voltage (TTL)	High: 3.3V to 3.5V Low: <1V	
Impedance	50 Ohm	
External Test Set Driver		
Function	Used for driving remote mixers	
Connections	3.5 mm (female)	
RF Output Frequency Range	3.2 GHz to 19 GHz	
LO Output Frequency Range	1.76 GHz to 26.5 GHz	
Rear Panel LO Power¹		
	Upper Limit, Typical (dBm)	Lower Limit, Typical (dBm)
1.7 GHz to 6.78 GHz	5	-3
6.78 GHz to 15.5 GHz	0	-6
15.5 GHz to 26.5 GHz	4	-5
Rear Panel RF Power		
	Upper Limit, Typical (dBm)	Lower Limit, Typical (dBm)
3.2 GHz to 19 GHz	-3	-8
VGA Video Output		
Connector	15-pin mini D-Sub; Drives VGA compatible monitors	
Devices Supported	Resolutions	
Flat Panel (TFT)	1024 X 768, 800 X 600, 640 X 480	
Flat Panel (DSTN)	800 X 600, 640 X 480	
CRT Monitor	1280 X 1024, 1024 X 768, 800 X 600, 640 X 480	
Simultaneous operation of the internal and external displays is allowed, but with 640 X 480 resolution only. If you change resolution, you can only view the external display (internal display will "white out").		

¹ LO output available in full analyzer's frequency range. The power is tested only from 3.2 GHz to 26.5 GHz.

Table 28. (Continued) Rear Panel Information, All Options

Description	Typical Performance
Bias Tee Inputs	
Connectors	BNC(f) for ports 1, 2, 3 and 4
Fuse	500 mA, bi-pin style
Maximum Bias Current	+/-200 mA with no degradation of RF specifications
Maximum Bias Voltage	+/-40 VDC
Trigger Inputs/Outputs	BNC(f), TTL/CMOS compatible
Test Set IO	25-pin D-Sub connector, available for external test set control.
Power IO	9-pin D-Sub, female; analog and digital IO
Handler IO	36-pin parallel I/O port; all input/output signals are default set to negative logic; can be reset to positive logic via GPIB command.
GPIB	Two ports - dedicated controller and dedicated talker/listener. 24-pin D-sub (Type D-24), female; compatible with IEEE-488.
Parallel Port (LPT1)	25-pin D-Sub miniature connector, female; provides connection to printers or any other parallel port peripherals
USB Ports	Four ports on front panel (all Host) and five ports (four Host and one Device) on rear panel. Type A configuration (eight Host) and Type B configuration (one Device), USB 2.0 compatible. The total current limit for all rear panel USB ports is 2.0 amps. The total current limit for all front panel USB is 0.9 amps.
LAN	10/100BaseT Ethernet, 8-pin configuration; auto selects between the two data rates
Line Power	
Frequency, Voltage	50/60/400 Hz for 100 to 120 VAC 50/60 Hz for 220 to 240 VAC
	Power supply is auto switching
Max	450 watts

Table 29. Analyzer Dimensions and Weight

All models are shipped with handles.

Cabinet Dimensions	Metric (mm)	Imperial (inches)
Height		
Without bottom feet: ¹ EIA RU = 6	266.1	10.5
With bottom feet	279.1	11.0
Width		
Without handles or rack-mount flanges	425.6	16.8
With handles, without rack-mount flanges	458.7	18.1
With handles and rack-mount flanges	482.9	19.0
Depth		
Without front and rear panel hardware	582.3	22.9
With front and rear panel hardware, handles	649.6	25.6

¹Electronics Industry Association rack units. 1 RU = 1.75 in.

See detailed PNA dimension drawings at: <http://na.tm.agilent.com/pna/PNADimensions.pdf>

Weight (nominal)	Net	Shipping
2-port models (Option 200, 201, 217, 219)	39.1 kg (86 lb)	55 kg (121 lb)
4-port models (Option 400, 401, 417, 419)	41.8 kg (92 lb)	58.2 kg (128 lb)

Regulatory and Environmental Information

For Regulatory and Environmental information, refer to the PNA Series Installation and Quick Start Guide, located online at <http://cp.literature.agilent.com/litweb/pdf/E8356-90001.pdf>.

Measurement Throughput Summary

- [Typical Cycle Time for Measurement Completion](#)
- [Cycle Time vs. IF Bandwidth](#)
- [Cycle Time vs. Number of Points](#)
- [Data Transfer Time](#)

Cycle time Includes sweep time, retrace time and band-crossing time. Analyzer display turned off with DISPLAY:ENABLE OFF. Add 21 ms for display on. Data for one trace (S₁₁) measurement.

Table 30a. Typical Cycle Time (ms) for Measurement Completion, All Models and Options

Sweep Range	IF Bandwidth		Number of Points				
			201	401	1601	16001	32001
9 GHz to 10 GHz	600 kHz	Uncorrected	5.5	5.5	9.4	59.4	116
		2-Port cal	17.2	18.0	16.6	132	250
	10 kHz	Uncorrected	28.1	53.1	203	1995	3988
		2-Port cal	65.6	116	414	4003	7991
	1 kHz	Uncorrected	227	445	1744	17028	33828
		2-Port cal	461	898	3150	30669	67680
10 GHz to 20 GHz	600 kHz	Uncorrected	17.2	18.8	23.4	68.8	120
		2-Port cal	43.8	46.9	56.3	155	259
	10 kHz	Uncorrected	67.2	127	259	2003	3995
		2-Port cal	144	261	523	4016	8003
	1 kHz	Uncorrected	233	456	1781	17375	34516
		2-Port cal	475	922	3570	34758	69055

Table 30b. N5221A Typical Cycle Time (ms) for Full-Span Measurement Completion

10 MHz to 13.5 GHz		Number of Points				
IF Bandwidth		201	401	1601	16001	32001
600 kHz	Uncorrected	48.4	59.4	78.1	156	206
	2-Port cal	105	127	164	317	428
10 kHz	Uncorrected	84.4	147	505	2172	4188
	2-Port cal	175	302	1016	4350	8384
1 kHz	Uncorrected	250	477	1822	17617	34984
	2-Port cal	505	959	3647	35250	69992

Table 30c. N5222A Typical Cycle Time (ms) for Full-Span Measurement Completion

10 MHz to 26.5 GHz		Number of Points				
IF Bandwidth		201	401	1601	16001	32001
600 kHz	Uncorrected	55.5	67.2	85.9	166	223
	2-Port cal	116	141	175	334	443
10 kHz	Uncorrected	87.5	151	512	2182	4203
	2-Port cal	180	307	1027	4364	8422
1 kHz	Uncorrected	252	480	1825	17648	35031
	2-Port cal	509	966	3656	35305	70086

Table 31. Cycle Time vs. IF Bandwidth - Typical

Applies to the Preset condition (201 points, correction off) except for the following changes:

- CF = 10 GHz
- Span = 100 MHz
- Display off (add 21 ms for display on)

Cycle time includes sweep and retrace time.

Description		N5221A/22A	
IF Bandwidth (Hz)	Cycle Time (ms)	Trace Noise Magnitude (dB rms)	
600,000	5.5	0.005	
100,000	5.5	0.0024	
30,000	8.6	0.0017	
10,000	28.9	0.0014	
3,000	70.3	0.001	
1,000	223	0.0008	
300	642	0.0006	
100	1823	0.0005	
30	5977	0.0005	
10	17836	0.0005	
3	59289	0.0004	

Table 32. Cycle Time vs. Number of Points - Typical

Applies to the Preset condition (correction off) except for the following changes:

- CF = 10 GHz
- Span = 100 MHz
- Display off (add 21 ms for display on)

Cycle time includes sweep and retrace time.

Description	IF Bandwidth (Hz)			
	1,000	10,000	30,000	600,000
3	6.3	4.7	4.7	4.7
11	15.6	5.5	4.7	4.7
51	59.4	10.2	4.7	4.7
101	113	15.6	6.3	4.7
201	222	28.1	8.6	4.7
401	436	53.1	14.1	5.5
801	859	103	23.4	6.3
1,601	1706	203	43.8	9.4
6,401	6719	800	166	26.6
16,001	16656	1995	408	60.2
32,001	33086	3988	812	116

Table 33. Data Transfer Time (ms) - Typical

Measured with the analyzer display off.

Values will increase slightly if the analyzer display is on.

Description	Number of Points				
	201	401	1601	16,001	32,001
SCPI over GPIB (Program executed on external PC ²)					
32-bit floating point	4.6	9.3	38	352	720
64-bit floating point	9.4	18.8	73.4	730	1455
ASCII	36.7	72.5	288	2882	5762
SCPI over SICL/LAN or TCP/IP Socket¹ (Program executed in the analyzer)					
32-bit floating point	<1	<1	<1	1.2	2.4
64-bit floating point	<1	<1	<1	2.3	4.6
ASCII	2.1	4	15	148	295
COM¹ (Program executed in the analyzer)					
32-bit floating point	<1	<1	<1	<1	<1
Variant type	<1	<1	1.4	12.4	25.5
DCOM over LAN¹ (Program executed on external PC)					
32-bit floating point	<1	<1	<1	2.3	4.4
Variant type	<1	1.6	5.3	52	105.5

¹ Values are for real and imaginary pairs, with the analyzer display off, using Gigabit Ethernet.

Note: Specifications for Recall & Sweep Speed are not provided for the N522xA analyzers.

Specifications: Front-Panel Jumpers

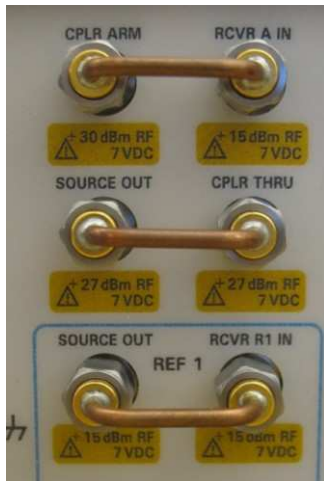

The following options have front-panel jumpers for each port:

201, 217, 219, 401, 417, 419

- [Measurement Receiver Inputs](#)
- [Reference Receiver Inputs and Reference Source Outputs](#)
- [Source Outputs](#)
- [Coupler Inputs](#)
- [Damage Level](#)

Table 34. Measurement Receiver Inputs (dBm) - Typical

(RCVR A, B, C, D IN) @ 0.1dB Typical Compression

Description	All Options
10 MHz to 500 MHz	-3
500 MHz to 1 GHz	-3
1 GHz to 2 GHz	-2
2 GHz to 3.2 GHz	-1
3.2 GHz to 10 GHz	-2
10 GHz to 26.5 GHz	-4
26.5 GHz to 35 GHz	-5
35 GHz to 50 GHz	-6

Table 35. Reference Receiver Inputs and Reference Source Outputs (dBm) - Typical
(RCVR R1 IN, REF 1 SOURCE OUT) @ Max Specified Output Power

Description	Option 201, 401	Option 217, 219, 417, 419
10 MHz to 50 MHz	-30	-30
50 MHz to 100 MHz	-16	-16
100 MHz to 500 MHz	-16	-16
500 MHz to 1 GHz	-8	-8
1 GHz to 10 GHz	-7	-8
10 GHz to 16 GHz	-8	-8
16 GHz to 26.5 GHz	-8	-9
26.5 GHz to 30 GHz	-9	-10
30 GHz to 32 GHz	-10	-11
32 GHz to 35 GHz	-9	-11
35 GHz to 43.5 GHz	-11	-12
43.5 GHz to 47 GHz	-15	-16
47GHz to 50 GHz	-24	-24

Table 36. Reference Receiver Inputs and Reference Receiver Outputs (dBm) - Typical**(RCVR R2 IN, RCVR R3 IN, RCVR R4 IN, REF 2 SOURCE OUT, REF 3 SOURCE OUT, REF 4 SOURCE OUT) @ Max Specified Output Power**

Description	Option 201, 401	Option 401	Option 217, 219, 417, 419	
	RCVR R2 IN, RCVR R4 IN, REF 2 SOURCE OUT, REF 4 SOURCE OUT	RCVR R3 IN, REF 3 SOURCE OUT	RCVR R2 IN, RCVR R4 IN, REF 2 SOURCE OUT, REF 4 SOURCE OUT	RCVR R3 IN, REF 3 SOURCE OUT
10 MHz to 50 MHz	-25	-25	-25	-25
50 MHz to 100 MHz	-20	-20	-20	-20
100 MHz to 500 MHz	-6	-6	-10	-10
500 MHz to 3.2 GHz	-2	-2	-3	-3
3.2 GHz to 10 GHz	-1	-1	-2	-2
10 GHz to 30 GHz	-1	-1	-1	-1
30 GHz to 32 GHz	-1	-1	-3	-3
32 GHz to 35 GHz	0	0	-1	-1
35 GHz to 43.5 GHz	-2	-2	-4	-4
43.5 GHz to 47 GHz	-5	-5	-7	-7
47 GHz to 50 GHz	-14	-14	-15	-15

Table 37. Source Outputs (dBm) - Typical**(PORT 1 SOURCE OUT, PORT 2 SOURCE OUT, PORT 3 SOURCE OUT, PORT 4 SOURCE OUT) @ Max Specified Output Power**

Description	Option 201, 401	Option 201, 401	Option 217, 219, 417, 419	
	PORT 1 SOURCE OUT, PORT 3 SOURCE OUT	PORT 2 SOURCE OUT, PORT 4 SOURCE OUT	PORT 1 SOURCE OUT, PORT 3 SOURCE OUT	PORT 2 SOURCE OUT, PORT 4 SOURCE OUT
10 MHz to 50 MHz	12	12	10	10
50 MHz to 1 GHz	13	13	11	11
1 GHz to 10 GHz	14	14	12	12
10 GHz to 16 GHz	14	14	13	13
16 GHz to 26.5 GHz	15	15	13	13
26.5 GHz to 30 GHz	14	14	12	12
30 GHz to 32 GHz	13	13	10	10
32 GHz to 35 GHz	14	14	12	12
35 GHz to 43.5 GHz	11	11	8	8
43.5 GHz to 47 GHz	8	8	4	4
47 GHz to 50 GHz	-2	-2	-5	-5

Table 38. Coupler Inputs (dB) - Typical**(PORT 1, 2, 3, 4 CPLR THRU) Insertion Loss of Coupler Thru**

Description	Option 201, 401	Option 217, 219, 417, 419
10 MHz to 50 MHz	0	0
50 MHz to 500 MHz	-0.25	-0.25
500 MHz to 1 GHz	-0.50	-0.50
1 GHz to 2 GHz	-0.50	-1
2 GHz to 3.2 GHz	-0.75	-1
3.2 GHz to 10 GHz	-1	-1.5
10 GHz to 16 GHz	-1.2	-2
16 GHz to 26.5 GHz	-1.8	-2.5
26.5 GHz to 35 GHz	-2	-3
35 GHz to 43.5 GHz	-2.5	-4
43.5 GHz to 47 GHz	-3	-5
47 GHz to 50 GHz	-3	-6

Table 39. Damage Level - Typical

Description	RF (dBm)	DC (v)
RCVR A, B, C, D IN	15	7
RCVR R1, R2, R3, R4 IN	15	7
REF 1 SOURCE OUT	15	7
REF 2, 3, 4 SOURCE OUT	30	7
PORT 1, 2, 3, 4 SOURCE OUT	27	7
PORT 1, 2, 3, 4 CPLR THRU	27	40 (7 ¹)
PORT 1, 2, 3, 4 CPLR ARM	30	7

¹ With a thru connection between test ports of option 217 or 417 configuration, 7 VDC input to CPLR THRU ports damages the source attenuator on the connected port..

Test Set Block Diagrams

NOTE: For best readability, use a color printer for printing the following graphics.

Legend

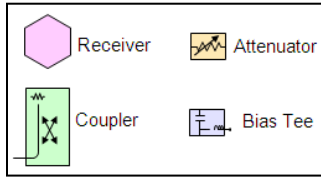

N5224A and N5225A Option 200 (2-port base model)

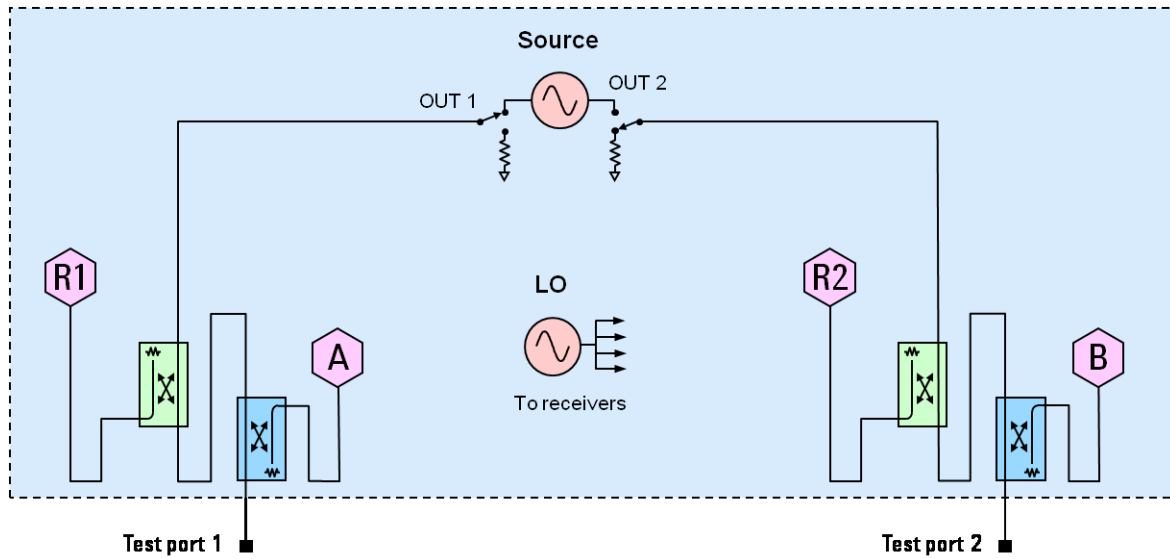

N5224A and N5225A Option 201

To base model, adds front-panel jumpers and R1 receiver switch

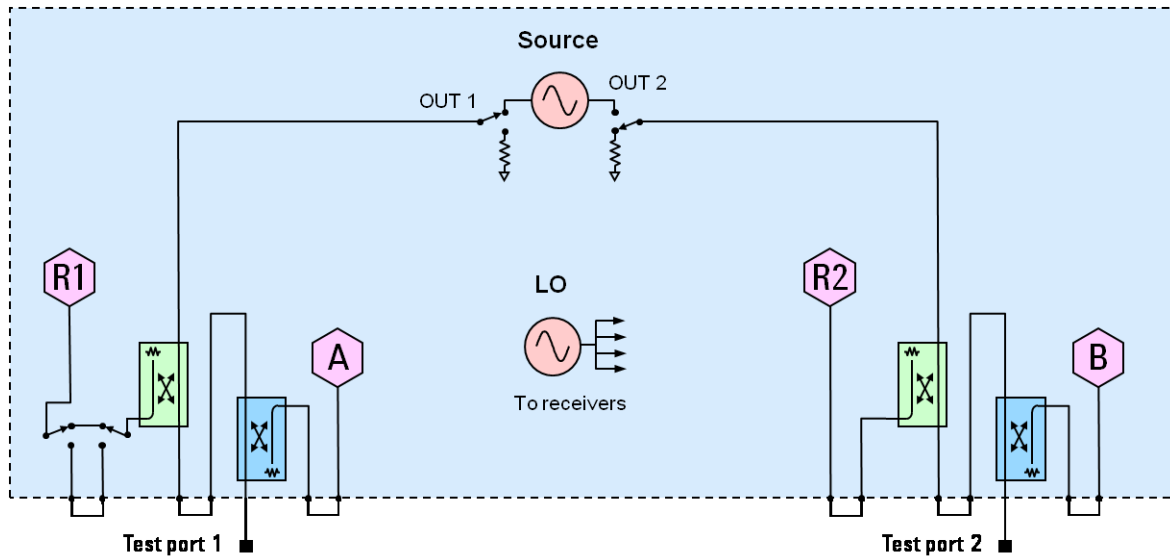

N5224A and N5225A Option 217

To base model, adds front-panel jumpers, R1 receiver switch, **and source and receiver attenuators (extended power range)**.

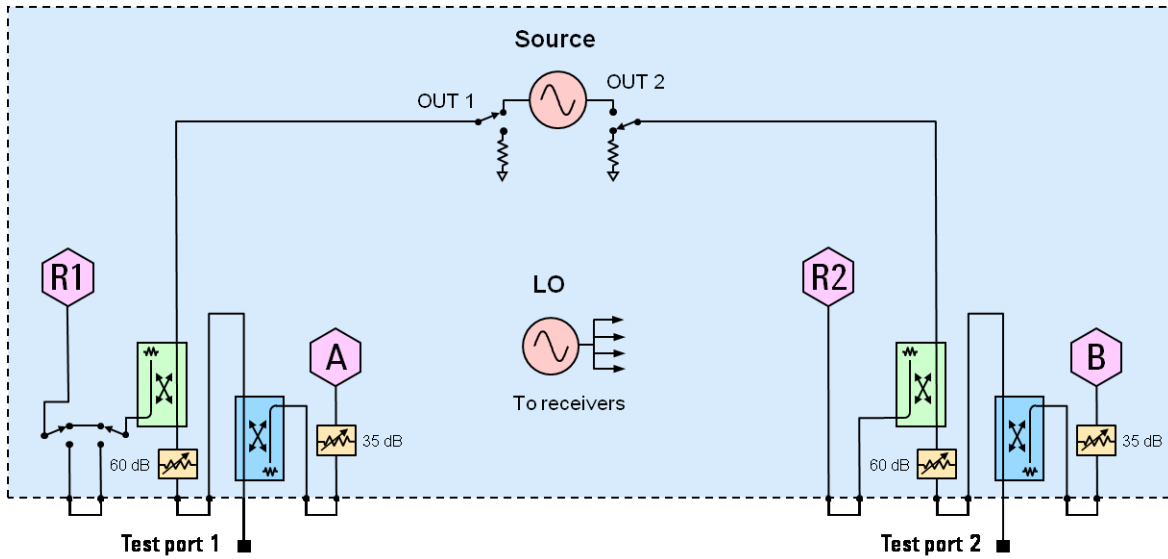

N5224A and N5225A Option 219

To base model, adds front-panel jumpers, R1 receiver switch, source and receiver attenuators (extended power range), **and bias-tees**.

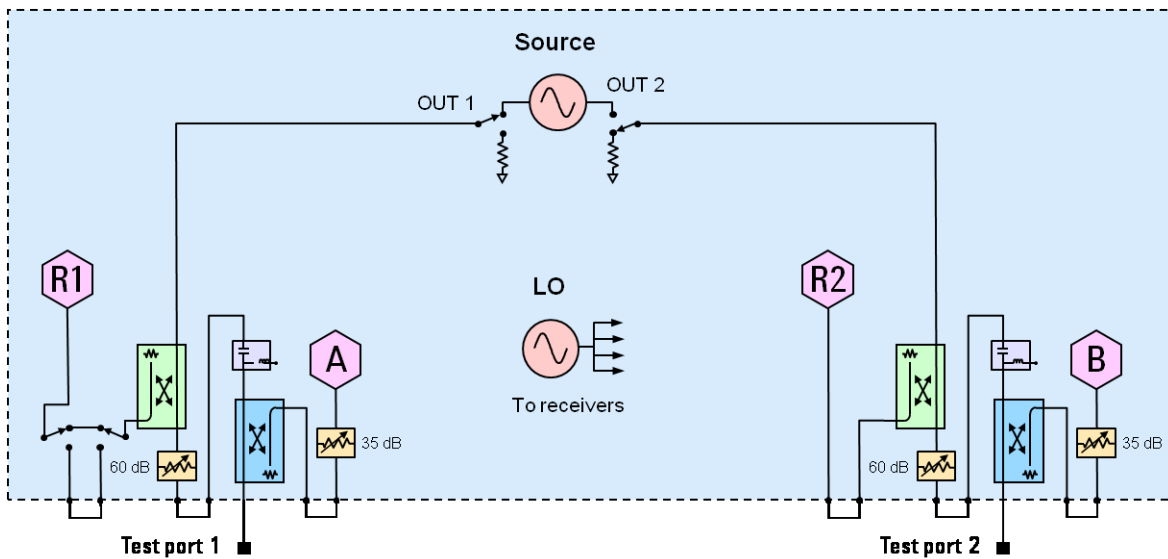

N5224A and N5225A Option 400 (4-port base model)

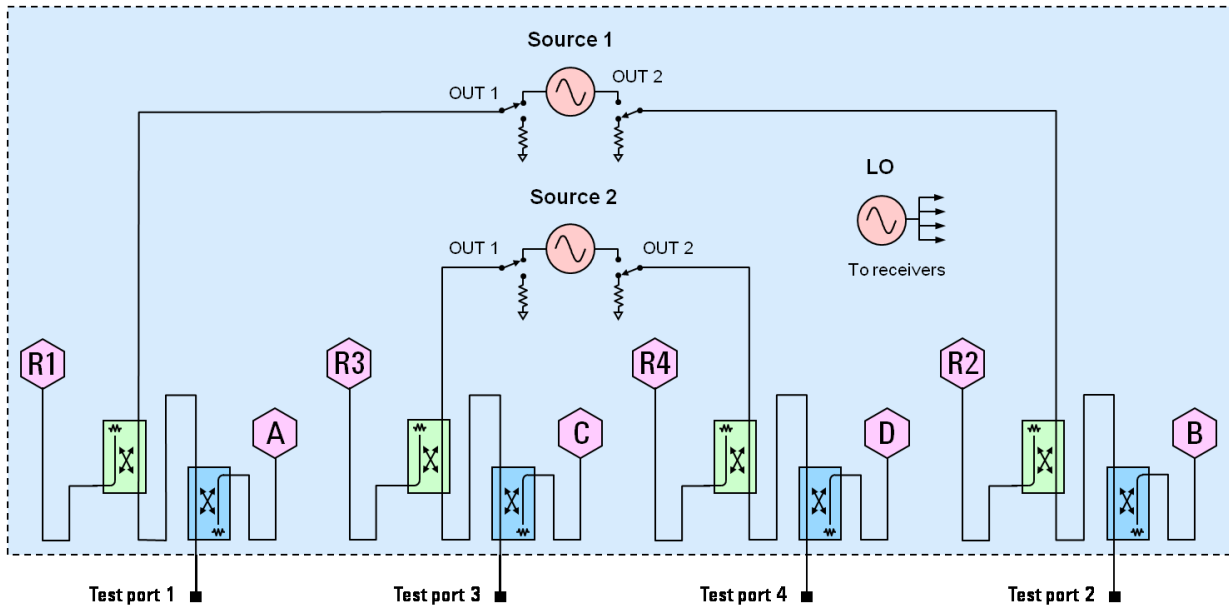

N5224A and N5225A Option 401

To base model, adds front-panel jumpers and R1 receiver switch

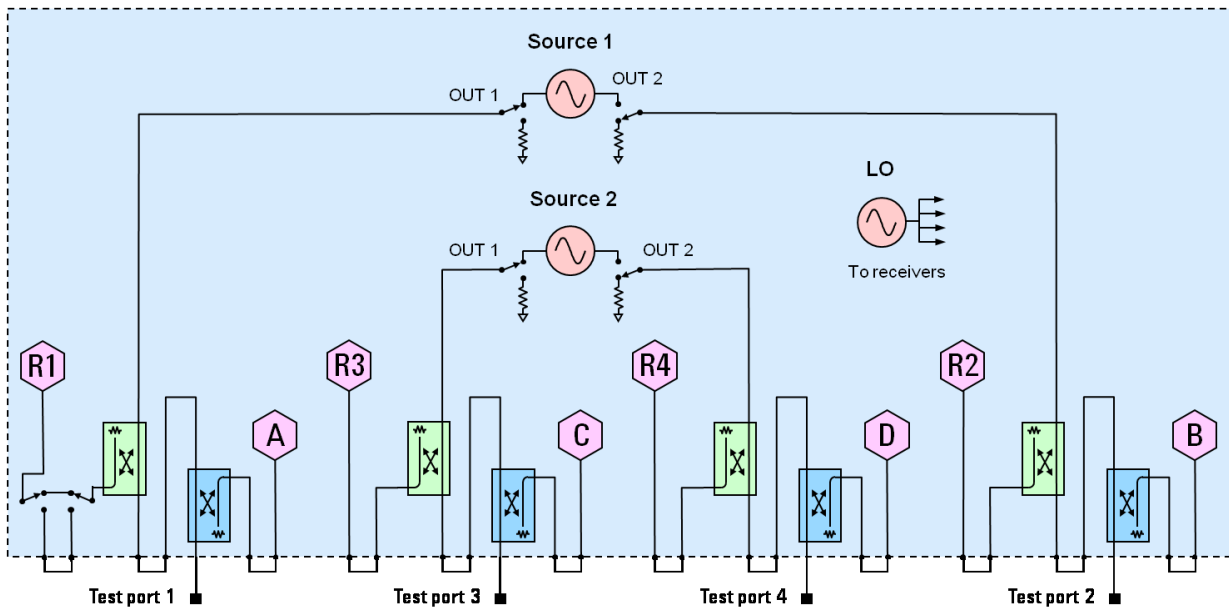

N5224A and N5225A Option 417

To base model, adds front-panel jumpers, R1 receiver switch, **and source and receiver attenuators (extended power range)**.

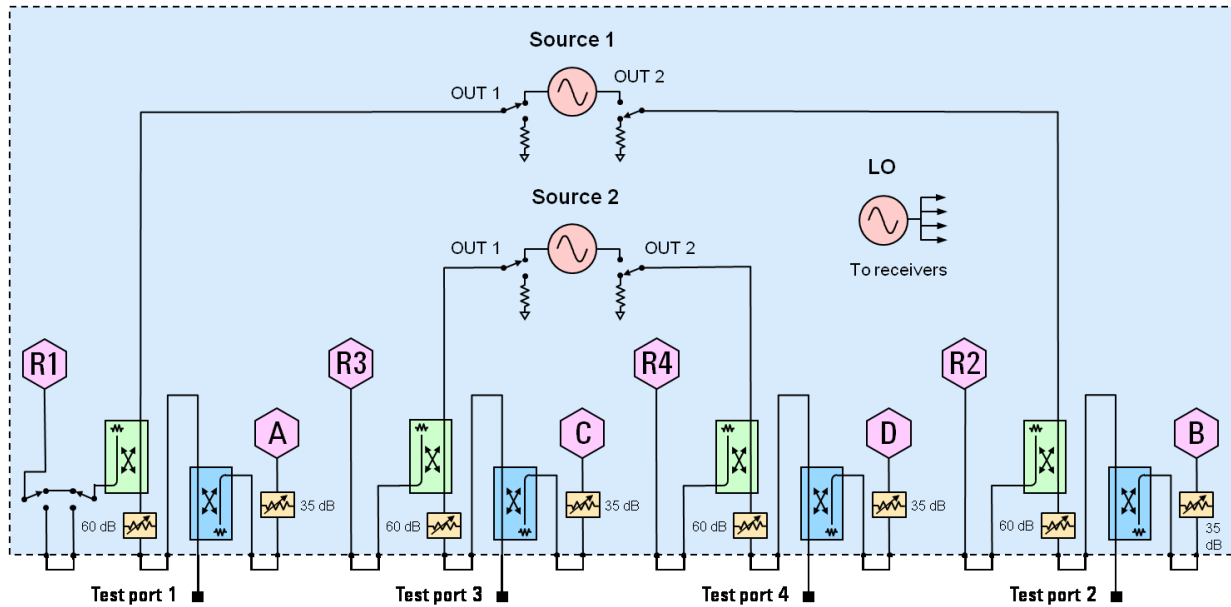

N5224A and N5225A Option 419

To base model, adds front-panel jumpers, R1 receiver switch, source and receiver attenuators (extended power range), **and bias-tees**.

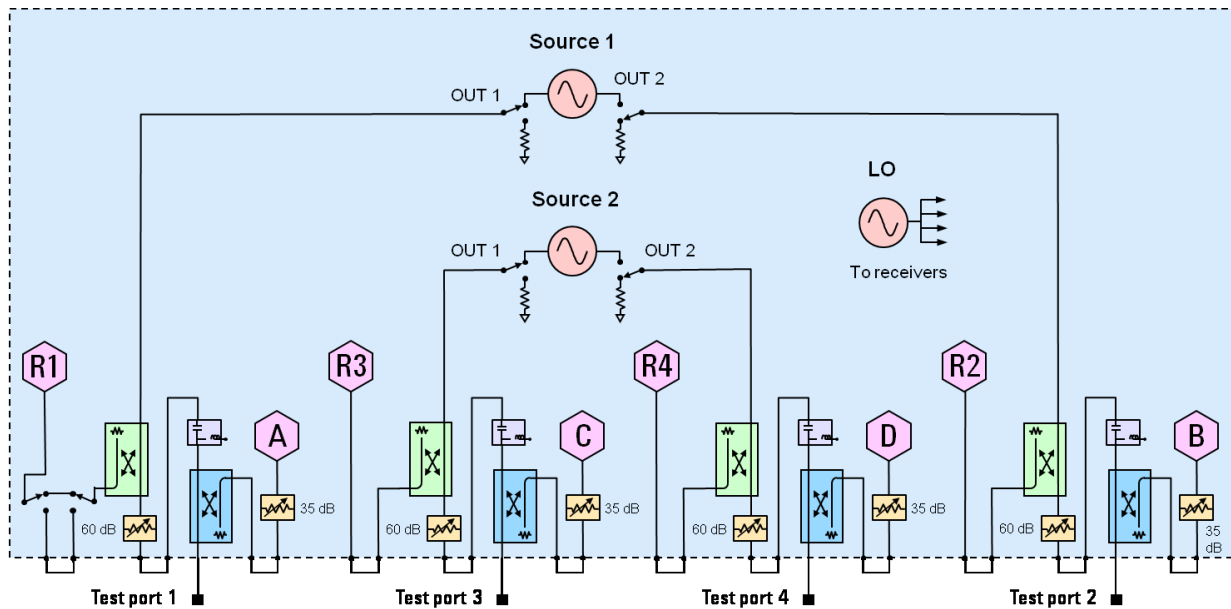

Receiver Block Diagram

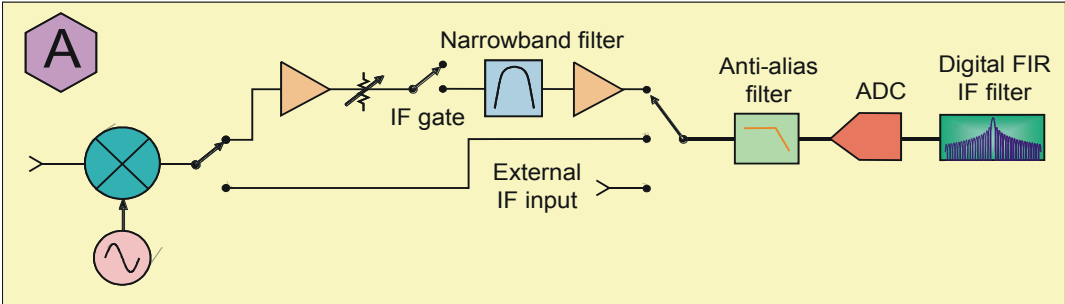



Agilent Email Updates

www.agilent.com/find/emailupdates

Get the latest information on the products and applications you select.



www.axiestandard.org

AdvancedTCA® Extensions for Instrumentation and Test (AXIe) is an open standard that extends the AdvancedTCA for general purpose and semiconductor test. Agilent is a founding member of the AXIe consortium.



www.lxistandard.org

LAN eXtensions for Instruments puts the power of Ethernet and the Web inside your test systems. Agilent is a founding member of the LXI consortium.



www.pxisa.org

PCI eXtensions for Instrumentation (PXI) modular instrumentation delivers a rugged, PC-based high-performance measurement and automation system.

Agilent Channel Partners

www.agilent.com/find/channelpartners

Get the best of both worlds: Agilent's measurement expertise and product breadth, combined with channel partner convenience.



Agilent Advantage Services is committed to your success throughout your equipment's lifetime. To keep you competitive, we continually invest in tools and processes that speed up calibration and repair and reduce your cost of ownership. You can also use Infoline Web Services to manage equipment and services more effectively. By sharing our measurement and service expertise, we help you create the products that change our world.

www.agilent.com/find/advantageservices



www.agilent.com

www.agilent.com/find/pnax

For more information on Agilent Technologies' products, applications or services, please contact your local Agilent office. The complete list is available at:

www.agilent.com/find/contactus

Americas

Canada	(877) 894-4414
Brazil	(11) 4197 3500
Mexico	01800 5064 800
United States	(800) 829-4444

Asia Pacific

Australia	1 800 629 485
China	800 810 0189
Hong Kong	800 938 693
India	1 800 112 929
Japan	0120 (421) 345
Korea	080 769 0800
Malaysia	1 800 888 848
Singapore	1 800 375 8100
Taiwan	0800 047 866
Other AP Countries	(65) 375 8100

Europe & Middle East

Belgium	32 (0) 2 404 93 40
Denmark	45 70 13 15 15
Finland	358 (0) 10 855 2100
France	0825 010 700* *0.125 €/minute
Germany	49 (0) 7031 464 6333
Ireland	1890 924 204
Israel	972-3-9288-504/544
Italy	39 02 92 60 8 484
Netherlands	31 (0) 20 547 2111
Spain	34 (91) 631 3300
Sweden	0200-88 22 55
United Kingdom	44 (0) 118 9276201

For other unlisted countries:

www.agilent.com/find/contactus

Product specifications and descriptions in this document subject to change without notice.

© Agilent Technologies, Inc. 2011
Published in USA, Dec. 12, 2011
Supersedes: Oct. 7, 2011
N5224-90001

