

Agilent 8474B/C/E

Planar-Doped Barrier Diode Detectors

0.01 to 50 GHz

Data Sheet

Features and description

- Exceptional flatness
- Broadband from 0.01 to 50 GHz
- Extremely temperature stable
- Environmentally rugged

The 8474 series of coaxial detectors are specifically designed for use in microwave instrumentation and systems. These detectors utilize a GaAs diode matched to a 50 ohm transmission line with a miniature thin film circuit.

The diodes are a Planar-Doped Barrier (PDB) structure fabricated by use of Molecular Beam Epitaxy technology. This combination yields a device which has superior characteristics to point-contact and low-barrier Schottky devices. These characteristics are reflected in frequency response specification and in square law response vs. frequency (Figure 7) with PDB detectors showing a maximum square law response variation of 3% from 2 to 18 GHz vs. 9.5% for Schottky detectors.

These detectors are extremely rugged with high resistance to ESD damage and are less sensitive to temperature change than either point-contact or Schottky diodes. These products offer 10 MHz to 50 GHz performance with the 2.4 mm connector (8474E) or narrower frequency coverage with APC-7 Type N or SMA-compatible 3.5 mm and 2.92 mm connectors. There is no need to order matched pairs because the frequency tracking is better than the original matched pair specifications.

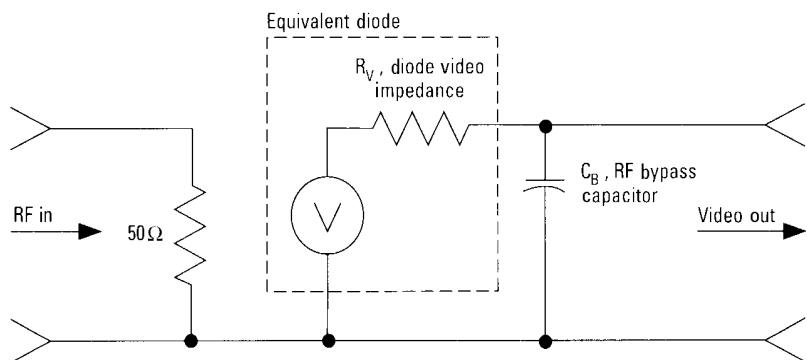

Figure 1. Equivalent circuit for 8474A/B/C/D/E with typical parameters

Typical values:

R_V (diode video impedance) = 1.5 k Ω *
 C_B (RF bypass capacitor) = 27 pF nominal

$$TR \text{ (10 to 90\% risetime)} = 2.2 \frac{(R_{LOAD}) (R_V)}{R_{LOAD} + R_V} (C_B + C_{LOAD}) = \frac{0.35}{BW}$$

*@ 25 \u00b0 C and PIN \leq 20 dBm (see Figure 7)

Detector performance characteristics

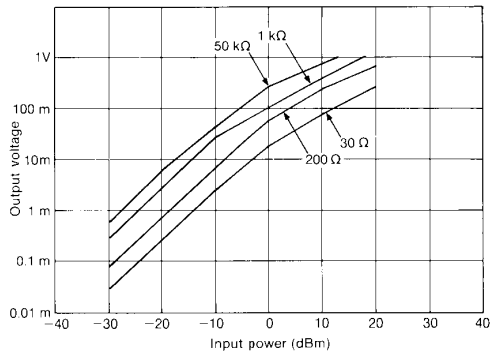

Figure 2. Typical transfer characteristics ($T_a = 25^\circ\text{C}$).

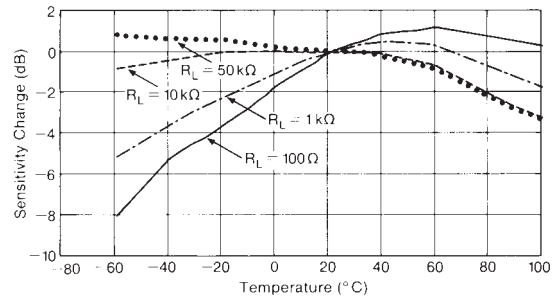

Figure 5. Typical output response with temperature. ($P_{in} \leq 20\text{ dBm}$)

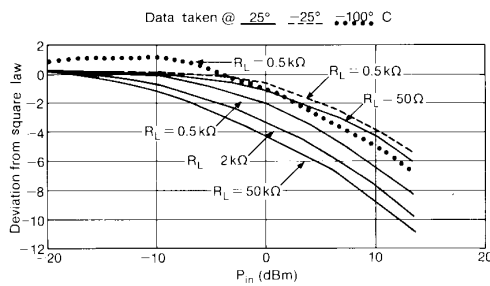

Figure 3. Typical square law deviation.

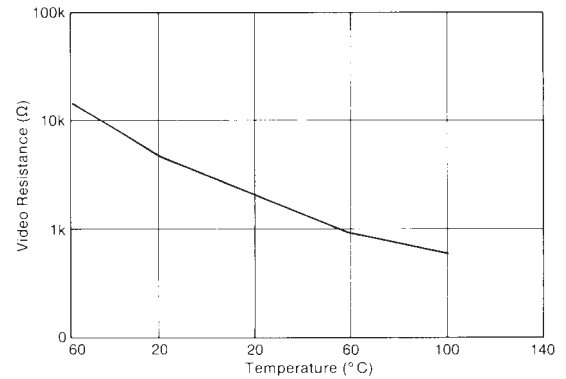

Figure 6. Typical video impedance variation with temperature.

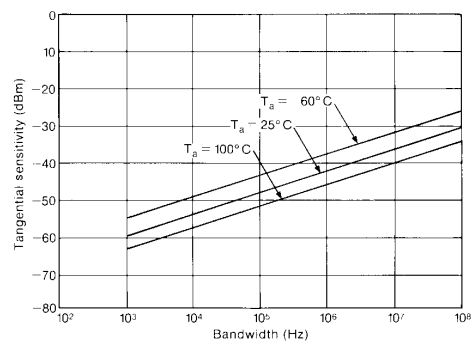

Figure 4. Typical tangential sensitivity.

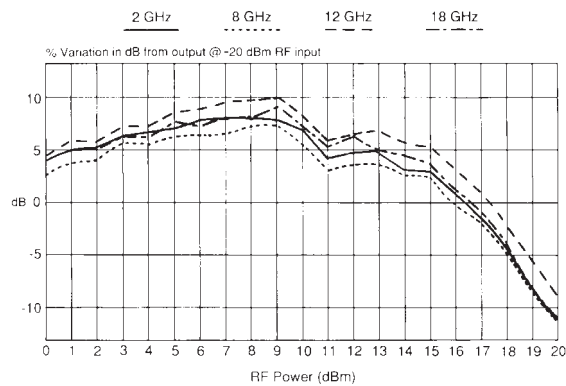

Figure 7. Typical square law deviation due to frequency.

Specifications

	8474B	8474C	8474E
Frequency range:	0.01-18 GHz	0.01-33 GHz	0.01-50 GHz
Frequency response	±0.35 dB	±0.45 dB from 0.01 to 26.5 GHz	±0.4 dB from 0.01 to 26.5 GHz
		±0.7 dB from 26.5 to 33 GHz	±0.6 dB from 26.5 to 40 GHz
			±1.0 dB from 40 to 50 GHz
SWR:	<1.3	<1.4 .01- 26.5 GHz	<1.2 .01- 26.5 GHz
		<2.2 26.5- 33 GHz	<1.6 26.5- 40GHz
			<2.8 40-50 GHz
Low-level sensitivity:	>0.4 mV/μW	>0.4 mV/μW	>0.4 mV/μW
			>0.34 mV/μW 40-50 GHz
Max. operating inputs:	200 mW	200 mW	200 mW
Typical short- Term max. input:	0.75 watt (<1 min.)	0.75 watt (<1 min.)	0.75 watt (<1 min.)
Noise: (μV peak-to-peak with CW power applied to produce 100 MV output, 400 kHz BW)	<50 μV	<50 μV	<50 μV
Standard output polarity (default):	negative	negative	negative

Notes:

Above specifications are at 25° C and ≤20 dBm unless otherwise specified.
Negative polarity (Option 301) is a default option. Select Option 103 for positive polarity.

Mechanical information

	8474B	8474C	8474E
Dimensions	20.82 (0.82)	7.9 (0.31)	7.9 (0.31)
mm (inches)	59.86 (2.36)	41.15 (1.62)	37.36 (1.47)
	18.68 (0.74)	9.7 (0.38)	7.6 (0.30)
Input connector:	Type N (m)	3.5 mm (m) SMA compatible	2.4 mm (m) 1.85 mm compatible
Output connector:	BNC (f)	SMC (m)	SMC (m)
Net weight:	85.3 grams (3 oz.)	13.9 grams (0.49 oz.)	9.1 grams (0.32 oz.)

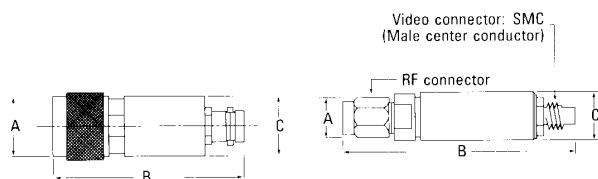

8474B

8474C/E

8474B Options	002	004	008	012	018	
Frequency range (GHz):	.01-2	2-4	4-8	8-12.4	12.4-18	
Frequency response (dB):	±0.25	±0.25	±0.25	±0.25	±0.35	
SWR:	<1.09	<1.1	<1.2	<1.3	<1.31	
8474C Options	004	008	012	018	026	033
Frequency range (GHz):	2-4	4-8	8-12.4	12.4-18	18-26.5	26.5-33
Frequency response (dB):	±0.2	±0.2	±0.25	±0.3	±0.3	±0.3
SWR:	<1.1	<1.16	<1.2	<1.3	<1.41	<2.2

Environmental

***Operating temperature:** -65 to 100° C

Temperature cycling (non-operating): MIL-STD 883, method 1010.1: (-65 to 100° C)

Vibration: MIL-STD 883, method 2007: (0.6" D.A. 20 to 80 Hz, 20g, 80 to 200 Hz)

Shock: MIL-STD 883, method 2002.1: (500g, 0.5 msec)

Acceleration: MIL-STD 883, method 2001: (500g)

Altitude: MIL-STD 883, method 1001: (50,000 ft, 15,240 m)

Salt atmosphere: MIL-STD 883, method 1009.1: (48 hr, 5% solution)

Moisture resistance: MIL-STD 883, method 1004.1: (25 to 40° C, 95% RH)

RFI: MIL-STD 461B

ESD: 10 hits at 25kV to the body, not the center conductor.

Ordering Information

Model	Option Number	Option Description
8474B	002	0.01 to 2 GHz octave only
	004	2 to 4 GHz octave only
	008	4 to 8 GHz octave only
	102 ¹	Square law load
	103	Positive Polarity
8474C	301	Negative Polarity
	008	4 to 8 GHz octave only
	012	8 to 12.4 GHz octave only
	033	26.5 to 33 GHz octave only
	103	Positive Polarity
	301	Negative Polarity

1. Option 102 external square law load extends the square law region of the detector with deviation of +/- 0.5 dB from the ideal square law response.

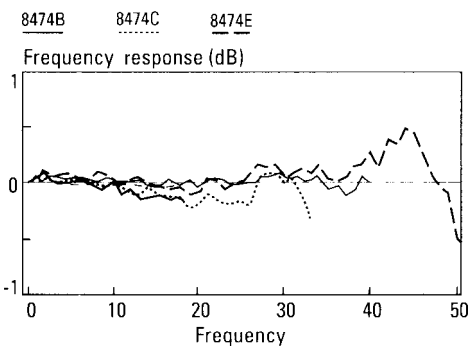

Figure 8. Typical frequency response.

* 8474A/B specified for 0° C - 75° C.

www.agilent.com
www.agilent.com/find/mta

For more information on Agilent Technologies' products, applications or services, please contact your local Agilent office.

The complete list is available at:

www.agilent.com/find/contactus

Americas

Canada	(877) 894 4414
Brazil	(11) 4197 3500
Mexico	01800 5064 800
United States	(800) 829 4444

Asia Pacific

Australia	1 800 629 485
China	800 810 0189
Hong Kong	800 938 693
India	1 800 112 929
Japan	0120 (421) 345
Korea	080 769 0800
Malaysia	1 800 888 848
Singapore	1 800 375 8100
Taiwan	0800 047 866
Other AP Countries	(65) 375 8100

Europe & Middle East

Belgium	32 (0) 2 404 93 40
Denmark	45 70 13 15 15
Finland	358 (0) 10 855 2100
France	0825 010 700*
	*0.125 €/minute
Germany	49 (0) 7031 464 6333
Ireland	1890 924 204
Israel	972-3-9288-504/544
Italy	39 02 92 60 8484
Netherlands	31 (0) 20 547 2111
Spain	34 (91) 631 3300
Sweden	0200-88 22 55
United Kingdom	44 (0) 131 452 0200

For other unlisted countries:

www.agilent.com/find/contactus

Revised: June 8, 2011

Product specifications and descriptions in this document subject to change without notice.

© Agilent Technologies, Inc. 2001, 2006, 2009-2011

Published in USA, December 14, 2011
 5952-0801