

Agilent Technologies

N5394A DVI Electrical Performance Validation and Compliance Software for Infiniium Oscilloscopes

Data Sheet

Verify and debug your DVI designs more easily

Agilent Technologies N5394A DVI electrical performance validation and compliance software for Infiniium Series oscilloscopes provides you with a fast and easy way to verify and debug your digital visual interface (DVI) designs for add-in cards, cables and motherboard systems. The DVI electrical test software allows you to automatically execute DVI electrical checklist tests, and displays the results in a flexible report format. In addition to the measurement data, the report provides a margin analysis that shows how closely your device passed or failed each test.

To make measurements with the N5394A DVI electrical test software, you also need the DVI Compliance Test Kit test fixtures, available through the DDWG¹ or Silicon Image, for hardware clock recovery and making measurements.

The N5394A DVI electrical test software performs a wide range of tests required to meet the DVI-1.0 electrical specifications for add-in cards, cables and motherboard systems as documented in section 4 of the base specification by the DDWG¹. To meet signal quality requirements, your product must successfully pass compliance testing based on the DVI specification. You must perform the tests included on the checklist before you submit your product for full compliance testing. The N5394A DVI electrical test software helps you execute a subset of the checklist tests for transmitters (Tx) and cables that can be measured with an oscilloscope.

Features

The N5394A DVI electrical test software offers several features to simplify the validation of DVI designs:

- Test setup wizard for ease-of-use
- All of the electrical tests specified by DVI test specification, full compliance of DVI tests
- Measurement process configurability
- Automated oscilloscope measurement setup
- Test results report generation
- Pass/fail margin analysis

With the DVI electrical test software, you can use the same oscilloscope you use for everyday debugging to perform automated testing and margin analysis based on the DVI-specified test checklist.

¹ Digital Display Working Group (www.ddwg.org)

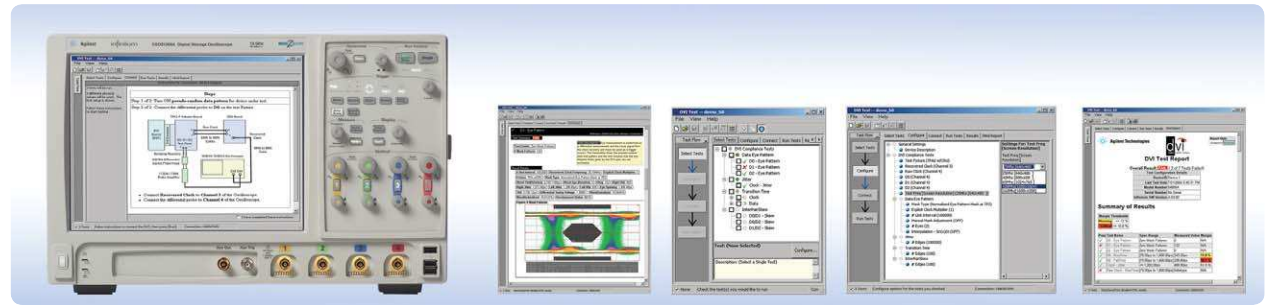

N5394A saves you time

The N5394A DVI electrical test software saves you time by setting the stage for automatic execution of DVI electrical tests. Part of the difficulty of performing electrical tests for DVI is hooking up the oscilloscope, setting up the proper configuration, and then analyzing the measured results by comparing them to limits published in the specification. The DVI electrical test software does much of this work for you. In addition, if you discover a problem with your device, debug tools are available to aid in root-cause analysis.

The N5394A DVI electrical test software offers the four fundamental DVI electrical tests. The software automatically configures the oscilloscope for each test, and it provides an informative results report that includes margin analysis indicating how close your product is to passing or failing that specification. For many tests, a selection is allowed on specific measurement parameters. Clock recovery of the TMDS clock is accomplished with the DVI Compliance Test Kit Clock Recovery Unit (CRU) board to ensure proper test results. See Table 2 for a complete list of the measurements made by the DVI electrical test software.

Easy test definition

The N5394A DVI electrical test software extends the ease-of-use advantages of Agilent's Infiniium Series oscilloscopes to testing DVI designs. The Agilent automated test engine walks you quickly through the steps required to define the tests, set up the test, perform the tests, and view the test results. You can select a

category of tests all at once, or specify individual tests. You can save tests and configurations as project files and recall them later for quick testing and review of previous test results. Straightforward menus let you perform tests with a minimum of mouse clicks.

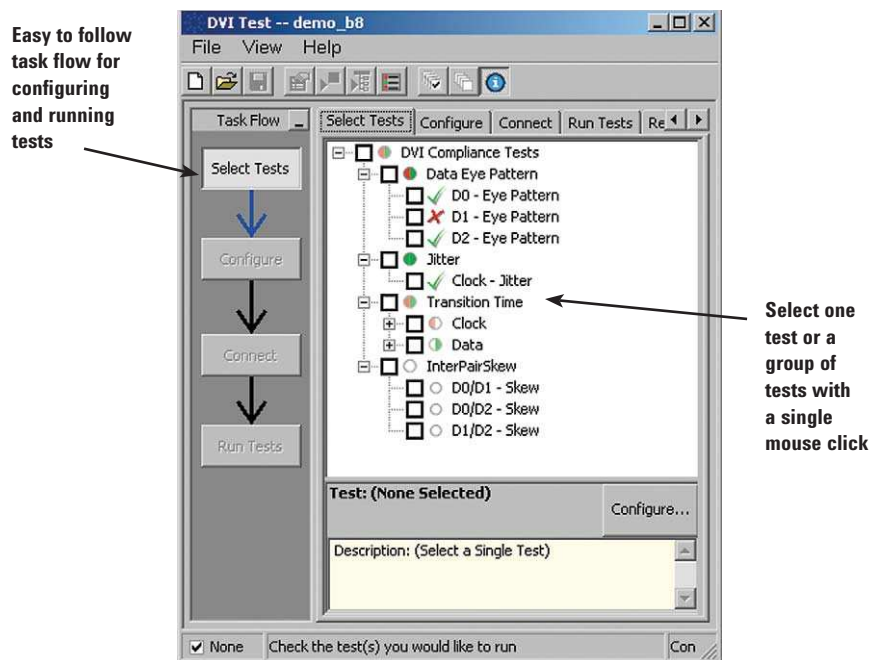
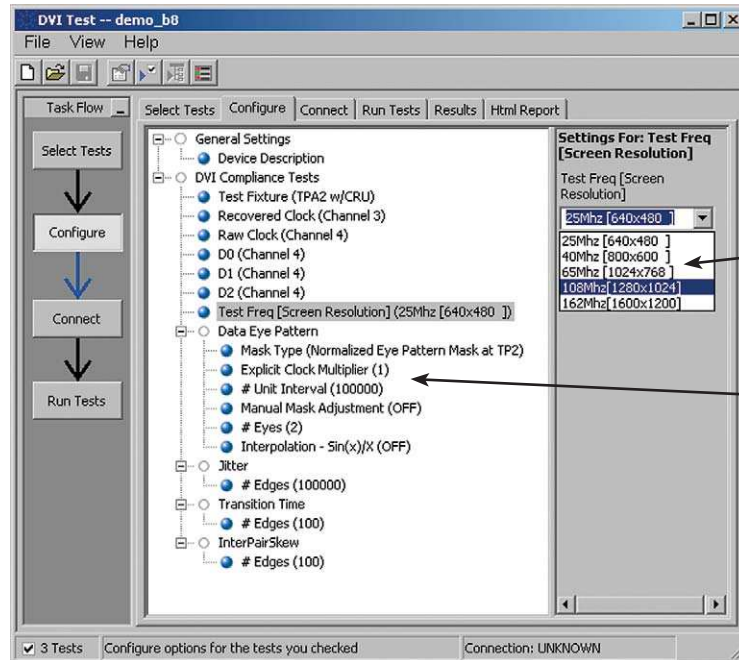

Figure 1. The Agilent automated test engine guides you quickly through selecting tests and configuring tests, setting up the connection, running the tests, and viewing the results. You can easily select individual tests or groups of tests with a mouse-click.

Configurability and guided connections

The N5394A DVI electrical test software provides flexibility in your test setup. It guides you to make connection changes with hookup diagrams when the tests you select require it.



For this test, select the test frequency from a range of choices

Test setup options are indicated for each test, including the present settings

Figure 2. In configuring the tests, you define the device to test, its configuration, and how the oscilloscope is connected.

For critical test parameters such as the horizontal voltage swing (V_{swing}) levels and worst-case intersections of the transmitter eye opening, you can choose to have the software automatically determine these values or manually set them on the displayed waveform.

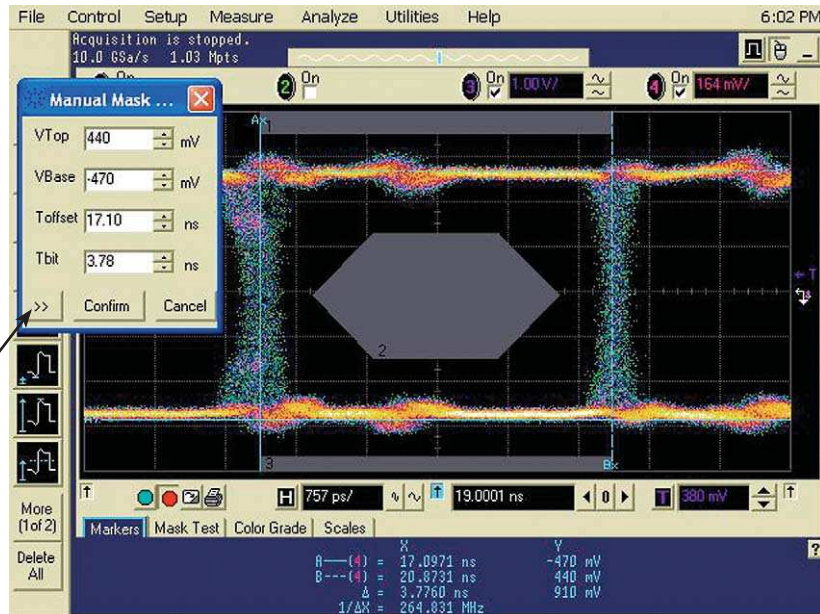

Select measurement modes can be set from a measurement waveform

Figure 3. The DVI electrical test software allows automatic or manual determination of the horizontal voltage swing levels.

All DVI electrical compliance tests you perform are based on the DVI Compliance Test Kit test fixtures. The Clock Recovery Unit (CRU) is used for hardware clock recovery. The Test Point Access Plug Board (TPA2-Plug) is used for compliance tests at the transmitter. The Test Point Access Receptacle Board (TPA2-Receptacle) is used for compliance tests at the end of a DVI cable and the input to the receiver. Connection to the compliance test fixtures is via the Agilent InfiniiMax active differential probes. The DVI Compliance Test Kit also includes files and procedures for creating the pseudo-random and half-clock patterns for the DVI product being tested.

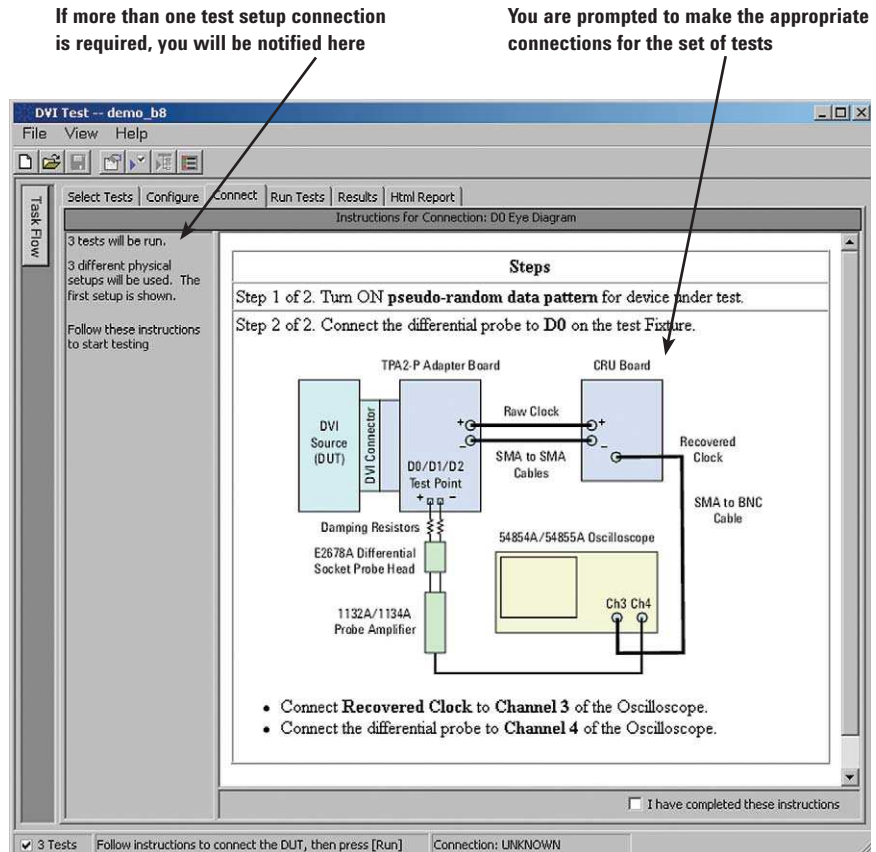

Figure 4. When you make multiple tests where the connections must be changed, the software prompts you with connection diagrams and/or photographs.

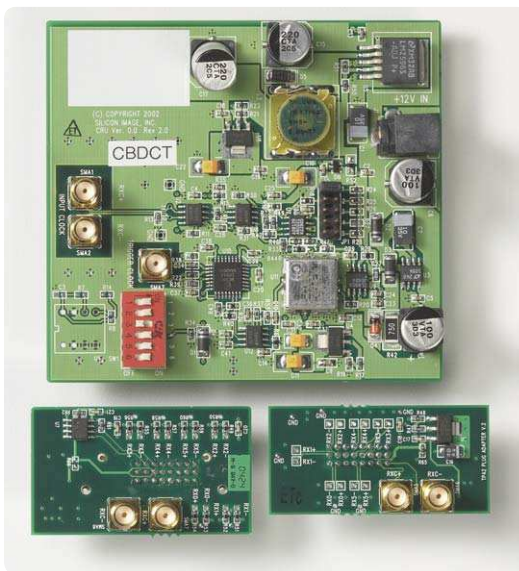

Figure 5. The Silicon Image DVI Compliance Test Kit CRU (Top board) and TPA2 fixtures (bottom boards).

Reports with margin analysis

In addition to providing you with measurement results, the N5394A DVI electrical test software provides a report format that shows you not only where your product passes or fails, but also reports how close you are to the limits specified for a particular test assertion. You select the margin test report parameter, which means you can specify the level at which warnings are issued to alert you to the electrical tests where your product is operating close to the official test limit defined by the DVI 1.0 specification for a given test assertion.

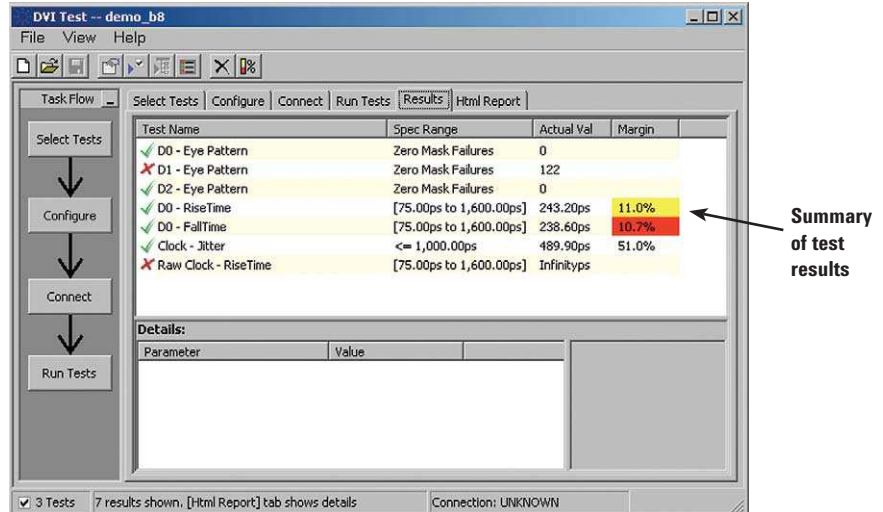

Figure 6. The DVI electrical test software results report documents your test, indicates the pass/fail status, the test specification range, the measured values, and the margin.

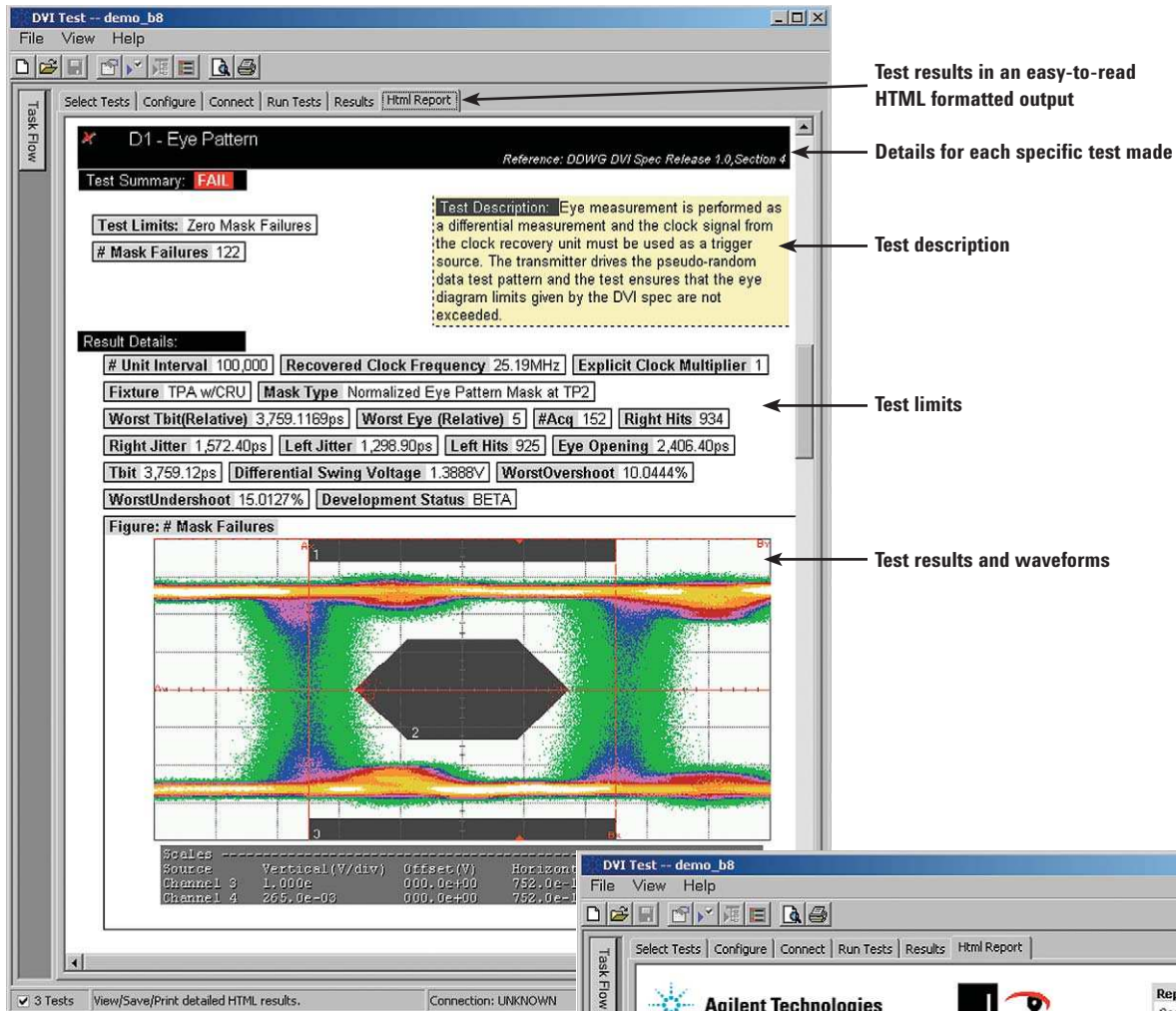

Figure 7. Additional details are available for each test including the test limits, test description, and test results, including waveforms, if appropriate.

Overall test description

User set margin thresholds for warning and failure indicators

Margin values indicate when the results are approaching test limits. Warnings and failures are highlighted.

Figure 8. How close your device comes to passing or failing a test is indicated as a % in the margin field. A result highlighted in yellow or red indicates your device has tripped the margin threshold level for a warning or failure.

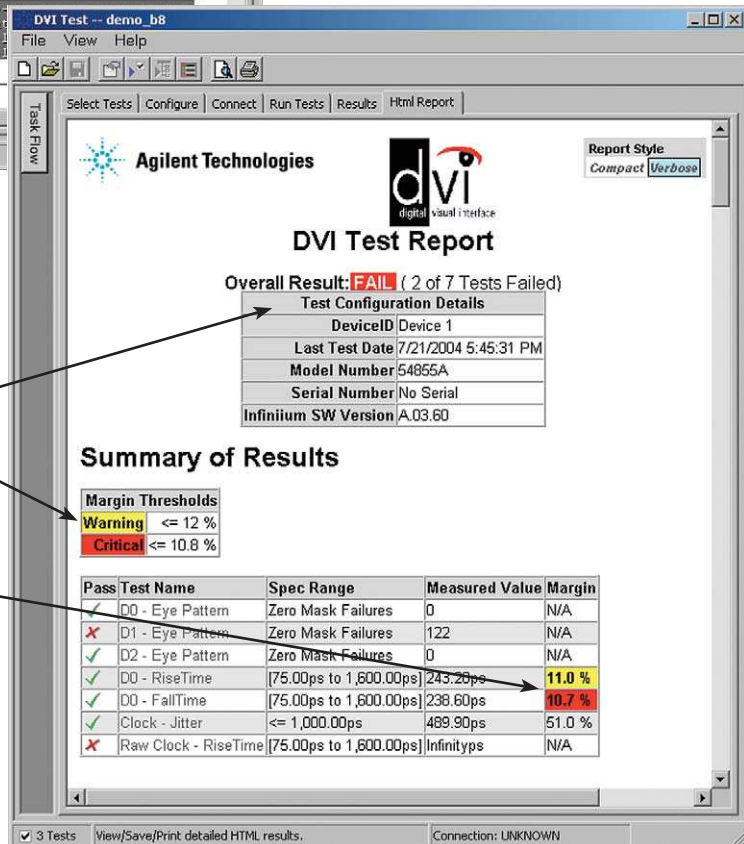

Extensibility

You may add additional custom tests or steps to your application using the N5467A User Defined Application (UDA) development tool (www.agilent.com/find/uda). Use UDA to develop functional “Add-Ins” that you can plug into your application.

Add-ins may be designed as:

- Complete custom tests (with configuration variables and connection prompts)
- Any custom steps such as pre or post processing scripts, external instrument control and your own device control

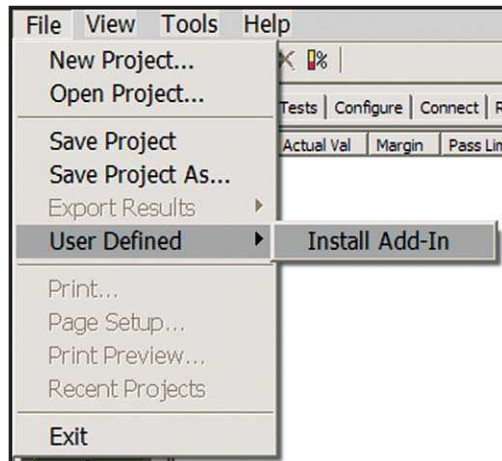

Figure 9. Importing a UDA Add-In into your test application.

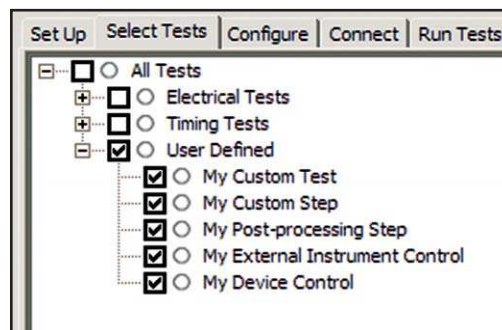

Figure 10. UDA Add-In tests and utilities in your test application.

Automation

You can completely automate execution of your application's tests and Add-Ins from a separate PC using the included N5452A Remote Interface feature (download free toolkit from: www.agilent.com/find/scope-apps-sw). You can even create and execute automation scripts right inside the application using a convenient built-in client.

The commands required for each task may be created using a command wizard or from "remote hints" accessible throughout the user interface. Using automation, you can accelerate complex testing scenarios and even automate manual tasks such as:

- Opening projects, executing tests and saving results
- Executing tests repeatedly while changing configurations
- Sending commands to external instruments
- Executing tests out of order

Combine the power of built-in automation and extensibility to transform your application into a complete test suite executive:

- Interact with your device controller to place it into desired states or test modes before test execution.
- Configure additional instruments used in your test suite such as a pattern generator and probe switch matrix.
- Export data generated by your tests and post-process it using your favorite environment, such as MATLAB, Python, LabVIEW, C, C++, Visual Basic etc.
- Sequence or repeat the tests and "Add-In" custom steps execution in any order for complete test coverage of the test plan.

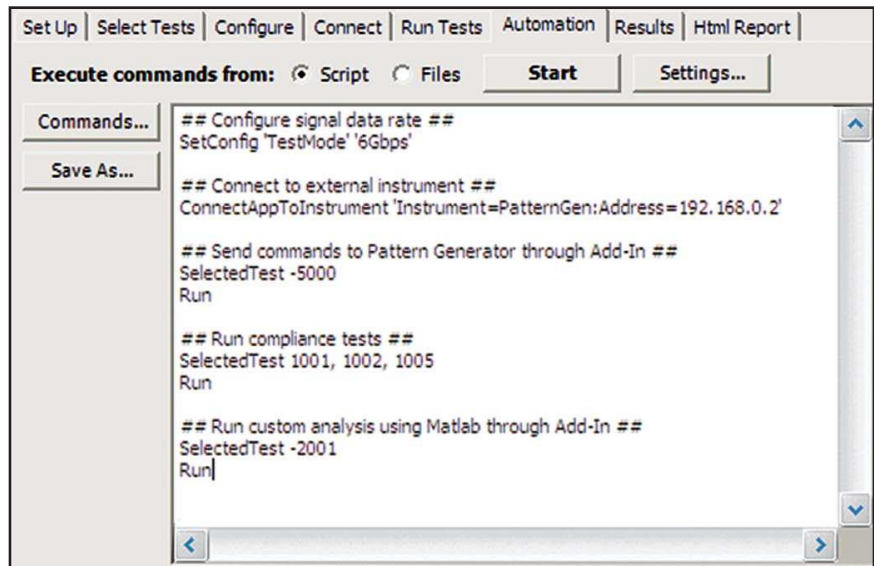

Figure 11: Remote Programming script in the Automation tab.

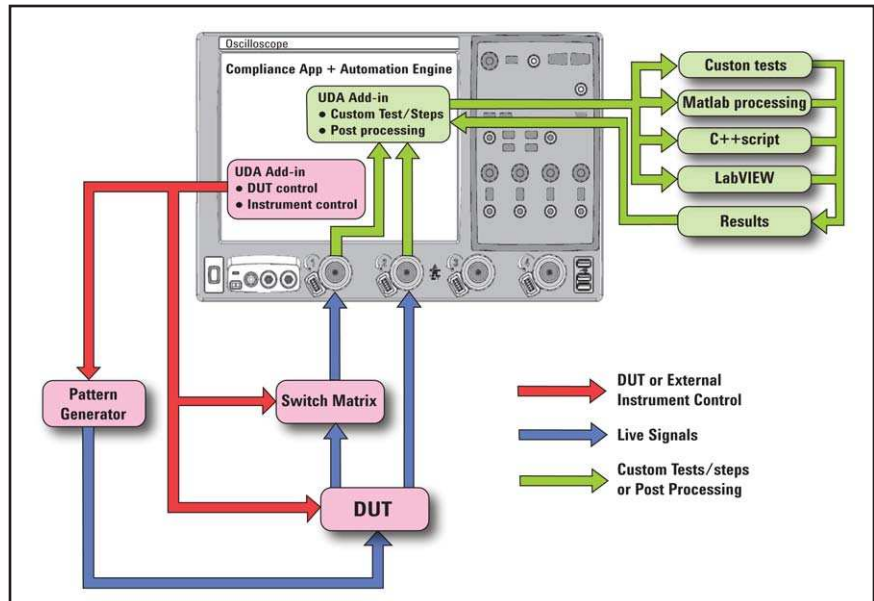

Figure 12: Combine the power of built-in automation and extensibility to transform your application into a complete test suite executive.

Measurement requirements

To use the N5394A DVI electrical performance validation and compliance software, you also need the DVI Compliance Test Kit (which contains the clock recovery unit, test point access fixtures, and cables), and at least two 3.5-GHz or higher InfiniiMax active differential probes (1131A, 1132A, 1134A, 1168A or 1169A) with appropriate probe heads (E2677A or N5381A solder-in or E2678A socketed).

The DVI Compliance Test Kit is available from your local Silicon Image distributor.

Recommended test accessories

To complete your test setup, Agilent provides a wide range of cables, adapters, terminations, etc.

Model number	Description
11667B	Power splitter, DC to 26.5 GHz, 3.5-mm (f) connectors
11636B	Power divider, DC to 26.5 GHz, 3.5-mm (f) connectors
8493B	Coaxial attenuator (3, 6, 10, 20 or 30 dB), DC to 18 GHz, SMA connector
1250-1158	SMA (f - f) adapter, DC to 18 GHz
1250-1159	SMA (m - m) adapter, DC to 18 GHz
1250-1397	Right-angle adapter, SMA (m - m)
1250-1741	Right-angle adapter, SMA (f - m)
1250-1698	SMA tee adapter (m, f, f), DC to 12.4 GHz
1250-1694	SMA (m) to SMA (f) Adapter
15442A	Cable kit, four 90-cm (36-in) SMA (m - m) cables
15443A	Matched cable pair, two 90-cm (36-in) SMA (m - m) cables, propagation delay within 25 ps
1810-0118	SMA (m) 50 Ω termination

Table 1. Recommended test accessories.

Oscilloscope compatibility

The N5394A DVI electrical performance validation and compliance software is compatible with all Infiniium oscilloscopes with operating software revision 5.30 or higher for DS080000 Series or 1.01 for DS090000A Series. For oscilloscopes with earlier software revisions, free upgrade software is available at www.agilent.com/find/infiniium_software

The N5394A DVI electrical performance validation and compliance software is compatible with Agilent 80000 Series oscilloscopes with operating software revision A.03.90 or higher.

Data rate	Recommended oscilloscope	Bandwidth of recommended oscilloscope
Up to 1.65 Gb/s	DS090404A	4 GHz
	DS090604A	6 GHz

Note: The required minimum bandwidth for DVI measurements is 4 GHz. N5394A DVI electrical performance validation and compliance software will run on all Infiniium models. These include Agilent 54850 Series, DS080000A/B Series, and DS090000A Series.

Tests performed

The N5394A DVI electrical performance validation and compliance software performs the following tests as per the DVI 1.0 electrical specifications for add-in cards, motherboard systems, and cables as documented in section 4 of the base specification.

Assertion Number	Description
Transmitter tests	
4.7.4	Rise/fall times
4.7.5	Skew
4.7.6	Eye-pattern
4.7.7	Jitter
Cable tests	
4.7.8	Eye-pattern
4.7.9	Skew

Table 2. DVI electrical tests performed by the N5394A software.

Ordering information

To purchase the N5394A DVI electrical performance validation and compliance software with a new or existing Infiniium oscilloscope, order the following:

Model number	Description
N5394A	DVI electrical test software for Infiniium oscilloscopes
113XA GHz	InfiniiMax active differential probe (1131A 3.5 GHz, 1132A 5 or 1134A 7 GHz)
E2677A or N5381A	InfiniiMax solder-in differential probe head
E2678A	InfiniiMax socketed differential probe head
An alternative to purchasing the E2677A and E2678A is the E2669A:	
E2669A	InfiniiMax connectivity kit for differential/single-ended measurements (contains one E2575A differential browser probe head, four E2677A solder-in differential probe heads, and two E2678A socketed differential probe heads)

Product Web site

For the most up-to-date and complete application and product information, please visit our product Web site at: www.agilent.com/find/scope-apps

Related Literature

Publication Title	Publication Type	Publication Number
<i>Infiniium 80000 Series Oscilloscopes and InfiniiMax II Series Probes</i>	Data Sheet	5989-4604EN
<i>Agilent Infiniium DSO/DSA90000A Series</i>	Data Sheet	5989-7819EN



Agilent Technologies Oscilloscopes

Multiple form factors from 20 MHz to >90 GHz | Industry leading specs | Powerful applications



Agilent Email Updates

www.agilent.com/find/emailupdates

Get the latest information on the products and applications you select.



www.axiestandard.org

AdvancedTCA® Extensions for Instrumentation and Test (AXIe) is an open standard that extends the AdvancedTCA for general purpose and semiconductor test. Agilent is a founding member of the AXIe consortium.



www.lxistandard.org

LAN eXtensions for Instruments puts the power of Ethernet and the Web inside your test systems. Agilent is a founding member of the LXI consortium.



www.pxisa.org

PCI eXtensions for Instrumentation (PXI) modular instrumentation delivers a rugged, PC-based high-performance measurement and automation system.

Agilent Channel Partners

www.agilent.com/find/channelpartners

Get the best of both worlds: Agilent's measurement expertise and product breadth, combined with channel partner convenience.

Agilent
Advantage
Services



Agilent Advantage Services is committed to your success throughout your equipment's lifetime. We share measurement and service expertise to help you create the products that change our world. To keep you competitive, we continually invest in tools and processes that speed up calibration and repair, reduce your cost of ownership, and move us ahead of your development curve.

www.agilent.com/find/advantageservices



Windows® is a U.S. registered trademark of Microsoft Corporation.

www.agilent.com
www.agilent.com/find/dvi

For more information on Agilent Technologies' products, applications or services, please contact your local Agilent office. The complete list is available at:

www.agilent.com/find/contactus

Americas

Canada	(877) 894 4414
Brazil	(11) 4197 3500
Mexico	01800 5064 800
United States	(800) 829 4444

Asia Pacific

Australia	1 800 629 485
China	800 810 0189
Hong Kong	800 938 693
India	1 800 112 929
Japan	0120 (421) 345
Korea	080 769 0800
Malaysia	1 800 888 848
Singapore	1 800 375 8100
Taiwan	0800 047 866
Other AP Countries	(65) 375 8100

Europe & Middle East

Belgium	32 (0) 2 404 93 40
Denmark	45 70 13 15 15
Finland	358 (0) 10 855 2100
France	0825 010 700*
	*0.125 €/minute
Germany	49 (0) 7031 464 6333
Ireland	1890 924 204
Israel	972-3-9288-504/544
Italy	39 02 92 60 8484
Netherlands	31 (0) 20 547 2111
Spain	34 (91) 631 3300
Sweden	0200-88 22 55
United Kingdom	44 (0) 131 452 0200

For other unlisted countries:

www.agilent.com/find/contactus

Revised: June 8, 2011

Product specifications and descriptions in this document subject to change without notice.

© Agilent Technologies, Inc. 2011
Published in USA, December 15, 2011
5989-1526EN



Agilent Technologies