



Agilent EEs of EDA

W1918 LTE-Advanced Baseband Verification Library

Baseband PHY Libraries for SystemVue

Data Sheet

Offering the Fastest Path from Algorithms to R&D Verification

Key Benefits:

- **Accelerate** your Physical Layer (PHY) design process with a superior modeling environment
- **Save time** with a trusted, independent IP reference from Agilent
- **Validate** BB & RF integration early, reducing project risk
- **Reduce** functional verification and NRE in R&D, with a streamlined process
- **Fill strategic gaps** using simulation, such as missing hardware and MIMO effects for early throughput testing
- **Interoperate** with test equipment, while the standard itself is still evolving
- **Re-use** the same Agilent IP and test assets throughout process



The W1918 LTE-Advanced Baseband Verification Library saves time, reduces engineering effort and accelerates the maturity of baseband PHY designs for next-generation 3rd Generation Partnership Project (3GPP) Long Term Evolution (LTE) systems. It enables system architects, algorithm developers and baseband hardware designers to investigate, implement and verify their Layer 1 3GPP LTE signal processing designs in the presence of meaningful RF and test signals. The libraries give the user piece of mind that a physical layer (PHY) meets or exceeds real-world performance requirements from the European Telecommunications Standards Institute (ETSI).

The Agilent W1918 LTE-Advanced Library provides the industry's first commercial design

support for the physical layer of 3GPP Release 10, enabling system and algorithm developers to deploy next-generation 4G performance with greater insight and greater confidence.

The W1918 LTE-A Baseband Verification Library is a Layer 1 simulation reference library option for Agilent SystemVue. The blockset, reference designs, and testbenches assist the design and verification of next-generation communication systems, by providing configurable physical layer waveforms and data for 3GPP Releases 8/9 (LTE) and 10 (LTE-Advanced). The library is useful for simulation-based exploration of challenging algorithms, up to 8x8 MIMO throughput verification, and integration with Agilent signal sources and analyzers.

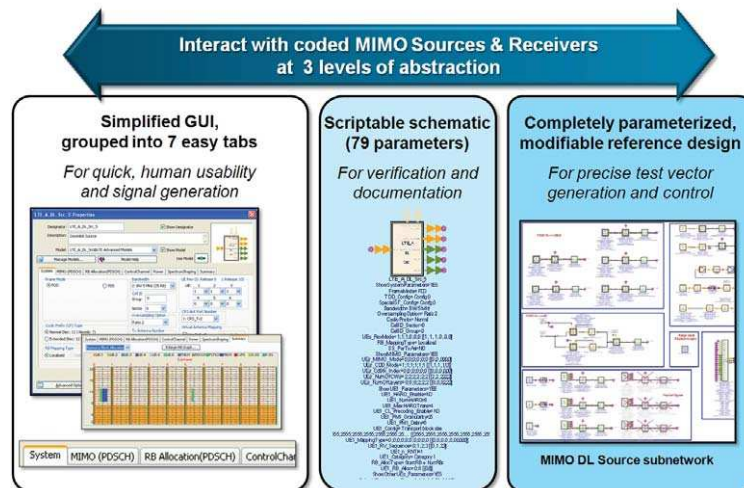

Figure 1. The W1918 LTE-Advanced Baseband Verification Library offers pre-packaged reference sources and receivers with a choice of three levels of user interfaces, as shown in this LTE-A MIMO downlink source example.



Features

- Working simulation-based baseband reference designs for UE & eNodeB
- Open, parameterized block diagrams allow unrestricted exploration and customization inside signal processing chain
- Generate any Layer 1 signal conditions, at any point inside the signal processing, or elsewhere in the environmental system
- Compare your internal test vectors against a trusted IP reference
- Use Agilent simulation blocks to:
 - supply missing functions/models
 - create complete Layer 1 scenarios
 - add MIMO, fading, RF, interferences
 - simulate BER/Throughput, before H/W
 - interoperate seamlessly with real Test

Configuration

The W1918 LTE-Advanced Baseband Verification Library can be added as an option to any SystemVue environment or bundle. It interoperates especially well with the W1715 MIMO Channel Builder modelset, and can be used with the W1716 Digital Pre-Distortion Builder module. The W1918 library adds LTE-Advanced algorithmic reference models to an existing modelset for LTE release 9.1, and is therefore a superset of the W1910 LTE library.

Requirements

- The W1918 library requires the SystemVue 2011.03 release, or later
- SystemVue 2011 runs on both 32- and 64-bit versions of Windows 7, Vista, or XP®. Network licensed configurations are especially affordable.
- W1918 is available as a perpetual software license with an annual support or as a cost-effective time-based license (0% residual).

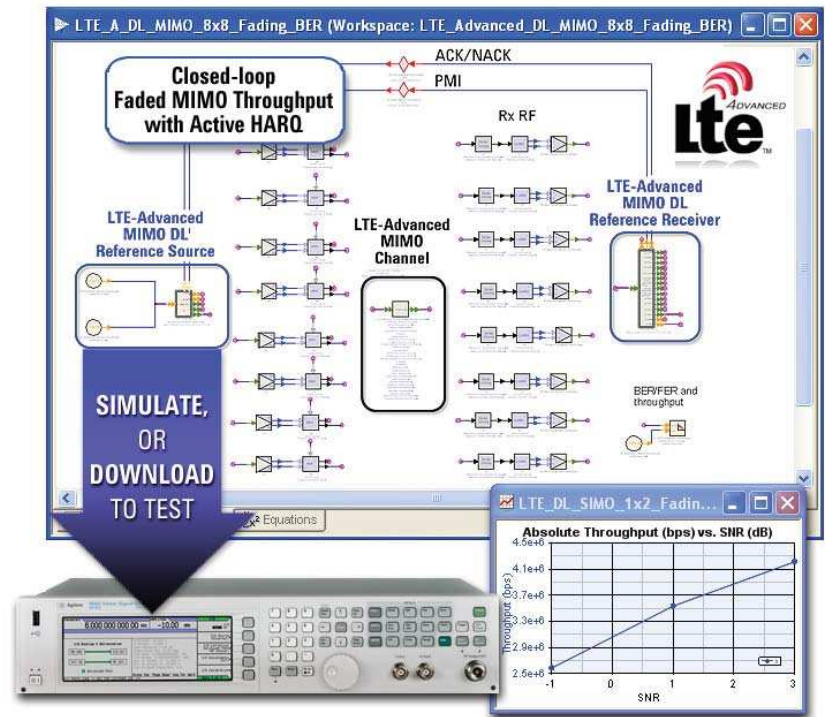

Figure 2. SystemVue's LTE-Advanced reference library provides the industry's first major design library support for 3GPP Release 10, and integrates with Agilent test equipment for early R&D design validation.

Table 1. W1918 LTE-Advanced Baseband Verification Library Overview

W1918 LTE-Advanced library includes:	Release 8/9 LTE	Release 10 LTE-Advanced
Compiled dataflow simulation blocks	123 parts	63 parts
C++ "exploraton" source code	Optional, add-on	Optional, add-on
Packaged MIMO Sources/receivers, w/GUI	10 ref designs	4 ref designs
Testbenches/reference exmples	17 examples	10 examples
Works with existing instrument H/W	Yes	Yes
Works with Agilent 89600 VSA and SignalStudio software personalities	Yes, also generates ".setx" files	Yes
Works with Agilent W1716 DPD	Yes	Yes
Works with Agilent W1715 MIMO Channel	Yes	Yes

Note: Support for Release 8/9 is also available as part of the SystemVue W1910 LTE baseband verification library.

Technical Specifications - LTE-Advanced (3GPP Release 10)

The W1918 LTE-Advanced Baseband Verification Library in SystemVue 2011.10 is based on 3GPP LTE Release 10 (Dec 2010). Agilent library updates are issued regularly to remain compatibility with the evolution of the standard.

- 3GPP TS 36.211 v10.0.0, "Physical Channels and Modulation", (Dec. 2010).
- 3GPP TS 36.212 v10.0.0, "Multiplexing and Channel Coding", (Dec. 2010).
- 3GPP TS 36.213 v10.0.0, "Physical Layer Procedures", (Dec. 2010).

LTE-Advanced Downlink baseband sources and receivers

- FDD and TDD
- Up to 8 TX and 8 RX antennas
- Localized and Distributed RB mapping
- Transmission Modes TM1-4, and 6-9
- Virtual antenna mapping, the mapping matrix can be configured
- Release 10 PDSCH transmission and Release 8 PDSCH transmission in the downlink source
- Closed-loop HARQ simulation by employing Dynamic Data Flow (DDF) and Matrix Data Type. Each codeword have one individual HARQ feedback loop.
- PDSCH
 - Full coding and decoding procedures for DL-SCH with or without HARQ retransmission
 - Three RB (resource block) allocations (StartRB+NumRBs, RB indices (1D), RB indices (2D))
 - Three transport block allocations (MCS index, transport block size and target code rate)
- Physical signals
 - Cell-specific reference signals
 - UE-specific reference signals (part 5, 7-14)
 - Synchronization signals, including primary and secondary synchronization signals
- Control channels
 - Full procedures for PCFICH, PHICH, PDCCH and PBCH, including information bits generation and channel coding
- Downlink power allocation according to TS36.213
- **Receiver baseband algorithm**
 - Support downlink timing and frequency synchronization, including:
 - Cross-correlation with two received P-SCH
 - Auto-correlation with local P-SCH
 - Two stages for timing synchronization: raw and fine synchronization
 - Integer and fractional frequency synchronization
 - Linear, MMSE-2D channel estimation
 - ZF (Zero Forcing) and ML (maximum likelihood) decoding for spatial multiplexing
 - Alamouti decoding for transmit diversity
 - Received soft bits combining for HARQ retransmission
 - Soft turbo decoder with specified iteration number

LTE-Advanced Uplink baseband source and receivers

- FDD and TDD
- Up to 4 Tx antennas and 4 Rx antennas
- Cluster SC-FDMA
- Simultaneous PUSCH and PUCCH transmission
- Maximal ratio combining (MRC) method for receiver diversity
- Closed-loop HARQ simulation by employing Dynamic Data Flow (DDF) and Matrix Data Type.
- PUSCH
 - Full coding and decoding procedures for UL-SCH with or without HARQ retransmission
 - PUSCH Hopping
 - Full multiplexing modes for PUSCH
 - UL-SCH Data and control multiplexing (as in 5.2.2 of 36.212)
 - Uplink control information only without UL-SCH data (as in 5.2.4 of 36.212)
 - Three RB (resource block) allocations (StartRB+NumRBs, RB indices (1D), RB indices (2D))
 - Three transport block allocations (MCS index, transport block size and target code rate)
- PRACH
 - DMRS for PUSCH
 - Preamble sequence generation and baseband signal generation
 - PRACH demodulation and detection
- PUCCH transmission
 - PUCCH Format 1, 1a, 1b, Shorten 1, Shorten 1a, Shorten 1b, 2, 2a and 2b.
 - Channel coding for control information bits on PUCCH
 - DMRS for PUCCH
- Sounding Reference Signal (SRS) transmission
- Uplink power allocation
- **Receiver baseband algorithm**
 - Uplink timing and frequency synchronization
 - Linear and MMSE channel estimation
 - Soft turbo decoder with specified iteration number

Carrier aggregation

- Carrier aggregation examples are provided, including both contiguous and non-contiguous carrier aggregation

Technical Specifications - LTE (3GPP Release 8/9)

The W1910 LTE Baseband Verification Library is based on 3GPP LTE Release 8/ 9 (March 2010). This LTE library is also included as part of the larger W1918 LTE-Advanced library, which further adds Release 10.

- 3GPP TS 36.211 v9.1.0, "Physical Channels and Modulation", March, 2010.
- 3GPP TS 36.212 v9.1.0, "Multiplexing and Channel Coding", March, 2010.
- 3GPP TS 36.213 v9.1.0, "Physical Layer Procedures", March, 2010

LTE Downlink Baseband MIMO sources and MIMO receivers

Downlink Sources

- FDD-LTE and TDD-LTE
- Transmission modes TM1-4, and 6-8
- Both Localized and Distributed RB mapping
- Closed-loop HARQ simulation by employing Dynamic Data Flow (DDF) and Matrix Data Type. Each codeword have one individual HARQ feedback loop.
- Closed-loop MIMO precoding for PDSCH, as described in 8.2.1.4 (Closed-loop spatial multiplexing) of 36.101
- Provides native downlink EVM measurements that are algorithmically compatible with Agilent 89600 VSA software v11.20 and later
- PDSCH
 - Full coding and decoding procedures for DL-SCH with or without HARQ retransmission
 - Three RB (resource block) allocations (StartRB+NumRBs, RB indices (1D), RB indices (2D))
- Three transport block allocations (MCS index, transport block size and target code rate)
- Physical signals
 - Cell-specific reference signals
 - Synchronization signals, including primary and secondary synchronization signals
 - UE-Specific Reference signals (port 5, port 7, port 8)
 - Positioning Reference signals (port 6)
- Control channels
 - Full procedures for PCFICH, PHICH, PDCCH and PBCH, including information bits generation and channel coding
- Downlink power allocation according to TS36.213
- Coded downlink signal sources provided for 1, 2, or 4 antenna ports

Downlink Receivers

- Downlink receiver solutions are provided for
 - 1 antenna, 2 antennas and 4 antennas
 - SISO (1x1), SIMO (1x2,1x4)
 - MIMO (2x2, 4x2, 4x4).
- Downlink HARQ performances meet the requirements defined in 8.2 Demodulation of PDSCH (Cell-Specific Reference Symbols) of TS36.101
- Control channel demodulation and decoding
- Auto generation of .setx configuration file for LTE personalities of Agilent 89600 VSA software

Downlink Receiver baseband algorithms

- Downlink timing and frequency synchronization, including
 - Cross-correlation with two received P-SCH
 - Auto-correlation with local P-SCH
 - Two stages for timing synchronization: raw and fine synchronization
 - Integer and fractional frequency synchronization
- Linear, MMSE-2D channel estimation, also the channel estimation for EVM measurement (defined in TS36.101) is provided
- Maximal ratio combining (MRC) method for receiver diversity
- ZF (Zero Forcing) , MMSE (minimum mean square error) and ML (Maximum likelihood) decoding for spatial multiplexing
- Alamouti decoding for transmit diversity
- Received soft bits combining for HARQ retransmission
 - soft turbo decoder with specified iteration number

LTE Uplink Baseband Sources and Receivers

- FDD-LTE and TD-LTE
- Uplink receivers with 1, 2 and 4 antenna ports
- Maximal ratio combining (MRC) method for receiver diversity
- Closed-loop HARQ simulation by employing Dynamic Data Flow (DDF) and Matrix Data Type.
- Provides Uplink EVM measurements that are algorithmically compatible with Agilent 89600 VSA software v11.20 and later
- PUSCH
 - Full coding and decoding procedures for UL-SCH with or without HARQ retransmission
 - PUSCH Hopping
 - Full multiplexing modes for PUSCH
 - UL-SCH Data and control multiplexing (as in 5.2.2 of TS36.212)
 - Uplink control information only without UL-SCH data (as in 5.2.4 of TS36.212)
 - Three RB (resource block) allocations (StartRB+NumRBs, RB indices (1D), RB indices (2D))
 - Three transport block allocations (MCS index, transport block size and target code rate)
- DMRS for PUSCH
- PRACH
 - Preamble sequence generation and baseband signal generation
 - PRACH demodulation and detection
- PUCCH
 - PUCCH Formats 1, Shorten 1, 1a, Shorten 1a, 1b, Shorten 1b, 2, 2a and 2b.
 - Channel coding for control information bits on PUCCH
 - DMRS for PUCCH
- Sounding Reference Signal (SRS)
 - SRS as defined in 5.5.3 of TS36.211
 - SRS as defined in 8.2 of TS36.213
- Uplink power allocation
- Control information decoding
- Uplink receiver solutions are provided for
 - 1 antenna.
 - HARQ SISO (1x1)
 - Non-HARQ SISO (1x1)

Uplink Receiver baseband algorithm

- Uplink timing and frequency synchronization
- Linear and MMSE channel estimation
- Soft turbo decoder with specified iteration number

LTE-Advanced Testbench Samples

Available LTE-Advanced Testbench Samples:

- 📁 LTE_Advanced_DL_Contiguous_CA_MXG_Gen.wsv
- 📁 LTE_Advanced_DL_MIMO_2x2_Throughput.wsv
- 📁 LTE_Advanced_DL_MIMO_8x8_Throughput.wsv
- 📁 LTE_Advanced_DL_NonContiguous_CA_MXG.wsv
- 📁 LTE_Advanced_DL_SISO_BER.wsv
- 📁 LTE_Advanced_DL_Tx.wsv
- 📁 LTE_Advanced_UL_MIMO_2x2_Throughput.wsv
- 📁 LTE_Advanced_UL_MIMO_4x4_Throughput.wsv
- 📁 LTE_Advanced_UL_SISO_BER.wsv
- 📁 LTE_Advanced_UL_Tx.wsv

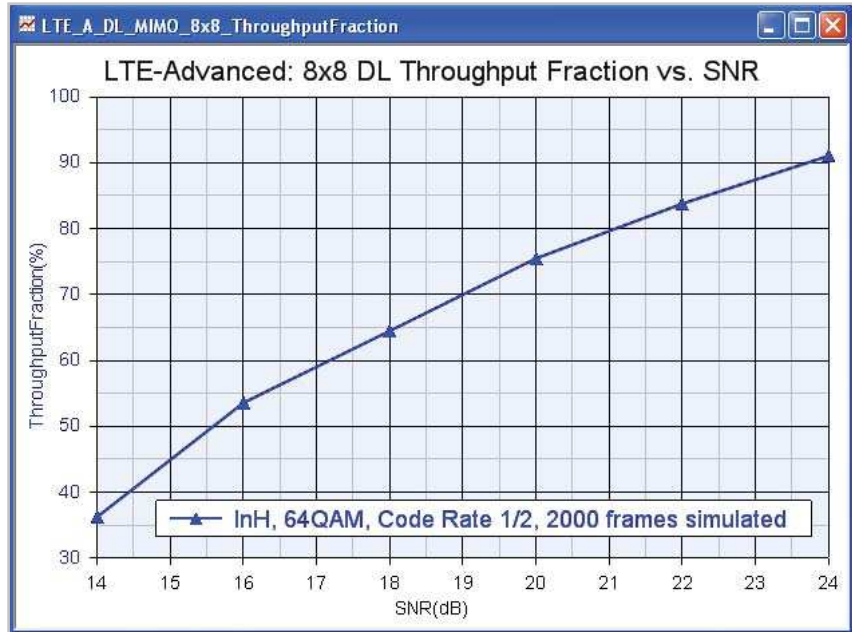

Figure 5. This 8x8 MIMO downlink transmitter example calculates the closed-loop throughput fraction for an LTE Advanced downlink transmitter with an 8-layer MIMO. Since 2000 frames of LTE-Advanced data for 8 MIMO channels represents a large number of simulated bits, these long verification simulations can be scripted and run automatically, for more convenience.

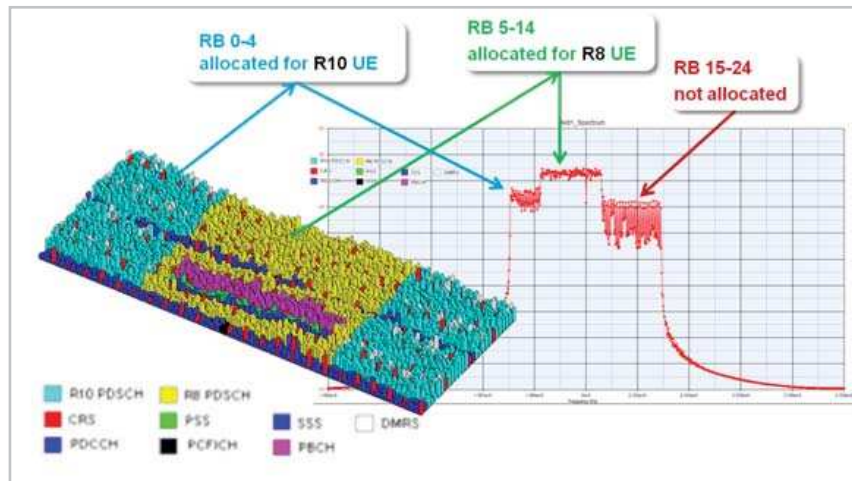

Figure 6. SystemVue LTE-Advanced allows you to configure algorithmic reference test vectors for the downlink transmitter, and mix allocations of Release 8 and Release 10 resource blocks.

LTE-Advanced Testbench Samples, continued

Available LTE-Advanced Testbench Samples:

- 📄 LTE_Advanced_DL_Contiguous_CA_MXG_Gen.wsv
- 📄 LTE_Advanced_DL_MIMO_2x2_Throughput.wsv
- 📄 LTE_Advanced_DL_MIMO_8x8_Throughput.wsv
- 📄 LTE_Advanced_DL_NonContiguous_CA_MXG.wsv
- 📄 LTE_Advanced_DL_SISO_BER.wsv
- 📄 LTE_Advanced_DL_Tx.wsv
- 📄 LTE_Advanced_UL_MIMO_2x2_Throughput.wsv
- 📄 LTE_Advanced_UL_MIMO_4x4_Throughput.wsv
- 📄 LTE_Advanced_UL_SISO_BER.wsv
- 📄 LTE_Advanced_UL_Tx.wsv

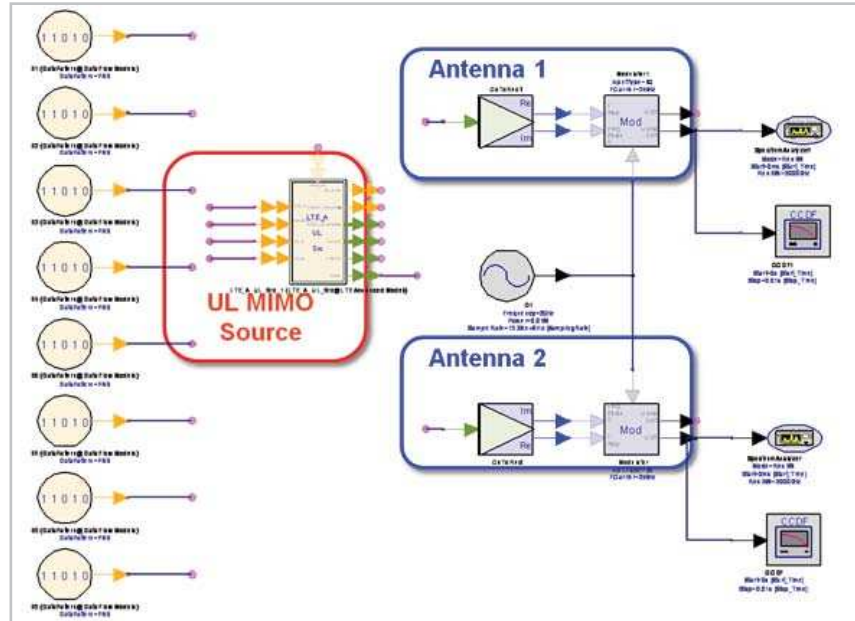

Figure 7. This 2x MIMO example demonstrates both a spectrum and CCDF measurement of an LTE Advanced uplink transmitter.

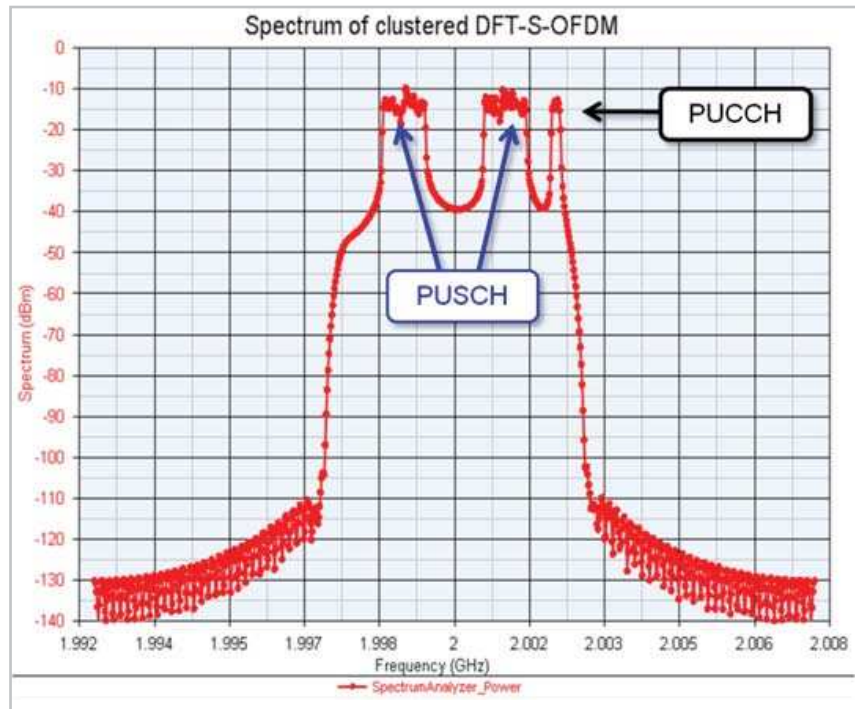

Figure 8. SystemVue LTE-Advanced allows you to analyze simultaneous PUSCH and PUCCH for the uplink transmitter.

LTE-Advanced Testbench Samples, continued

Available LTE-Advanced Testbench Samples:

- 📁 C-Code Generation
- 🔗 3GPP_LTE_CFR_EVM.wsv
- 🔗 3GPP_LTE_ControlInfo_ChannelCoding.wsv
- 🔗 3GPP_LTE_DL_ChannelCoding.wsv
- 🔗 3GPP_LTE_DL_ETM.wsv
- 🔗 3GPP_LTE_DL_MIMO_Throughput.wsv
- 🔗 3GPP_LTE_DL_SISO_BER.wsv
- 🔗 3GPP_LTE_DL_SISO_Tx.wsv
- 🔗 3GPP_LTE_DL_Tx_Beamforming.wsv
- 🔗 3GPP_LTE_DL_TxEVM.wsv
- 🔗 3GPP_LTE_SignalDownload.wsv
- 🔗 3GPP_LTE_UL_BER.wsv
- 🔗 3GPP_LTE_UL_ChannelCoding.wsv
- 🔗 3GPP_LTE_UL_PRACH_Detection.wsv
- 🔗 3GPP_LTE_UL_SIMO_Throughput.wsv
- 🔗 3GPP_LTE_UL_SISO_Throughput.wsv
- 🔗 3GPP_LTE_UL_SISO_TxEVM.wsv
- 🔗 3GPP_LTE_UL_TxEVM.wsv

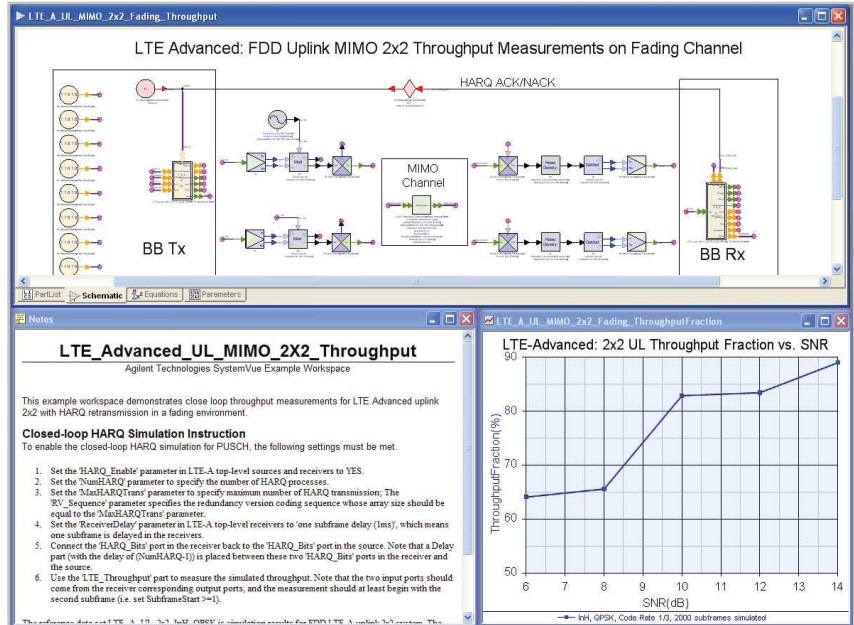

Figure 9. This closed-loop 2x MIMO example profiles the data throughput percentage vs. SNR, for an LTE-Advanced uplink transmitter with active HARQ feedback. SystemVue’s proprietary “dynamic dataflow” simulation engine makes dynamic radio reconfiguration possible during the simulation, while maintaining timing and carrier frequency information for accurate RF effects.

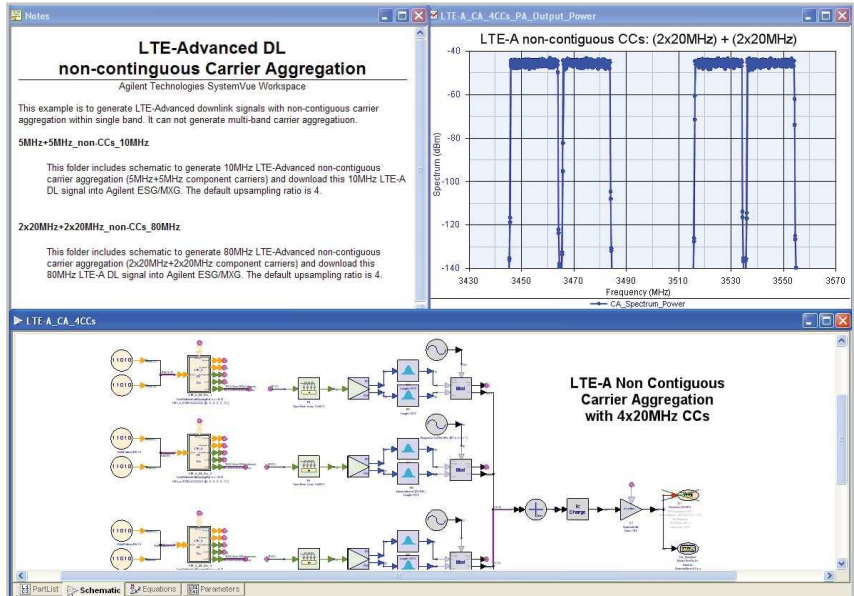

Figure 10. Non-Contiguous Carrier Aggregation (CA) is demonstrated in this example, by combining 4 Component Carriers (CC) that are each 20MHz bandwidth. Nonlinear RF/Analog impairments can be added to this system, creating EVM and throughput degradations more typical of loaded cells and interference-limited operation.

LTE Testbench Samples

Available LTE Testbench Examples:

- C-Code Generation
- 3GPP_LTE_CFR_EVM.wsv
- 3GPP_LTE_ControlInfo_ChannelCoding.wsv
- 3GPP_LTE_DL_ChannelCoding.wsv
- 3GPP_LTE_DL_ETM.wsv
- 3GPP_LTE_DL_MIMO_Throughput.wsv
- 3GPP_LTE_DL_SISO_BER.wsv
- 3GPP_LTE_DL_Tx.wsv
- 3GPP_LTE_DL_Tx_Beamforming.wsv
- 3GPP_LTE_DL_TxEVM.wsv
- 3GPP_LTE_SignalDownload.wsv
- 3GPP_LTE_UL_BER.wsv
- 3GPP_LTE_UL_ChannelCoding.wsv
- 3GPP_LTE_UL_PRACH_Detection.wsv
- 3GPP_LTE_UL_SIMO_Throughput.wsv
- 3GPP_LTE_UL_SISO_Throughput.wsv
- 3GPP_LTE_UL_TX.wsv
- 3GPP_LTE_UL_TxEVM.wsv

Note:

The W1918 LTE-Advanced Baseband Verification Library for SystemVue is a superset of the W1910 LTE Baseband Verification Library and includes both LTE and LTE-Advanced support.

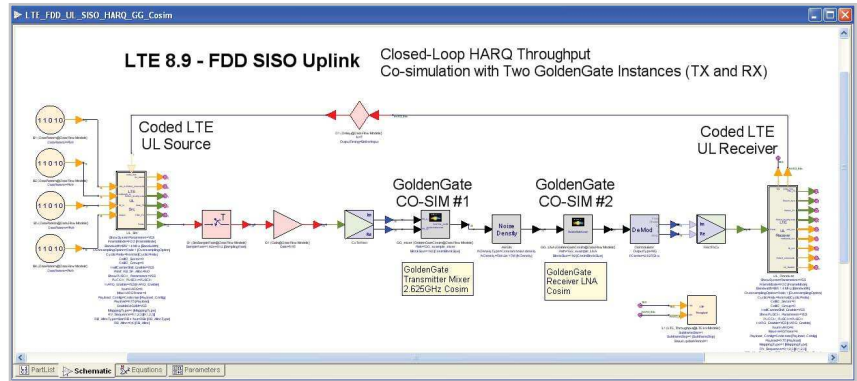

Figure 11. This LTE Throughput simulation includes live co-simulations with Agilent GoldenGate for two CMOS RFIC transceiver components. These are not behavioral models; the true envelope-level dynamic behavior can be verified down to the transistor level in a meaningful, standard-compliant test. This is useful for both the System Architect verifying the overall PHY performance, and also for the RFIC circuit designer prior to tape-out of the wafer.

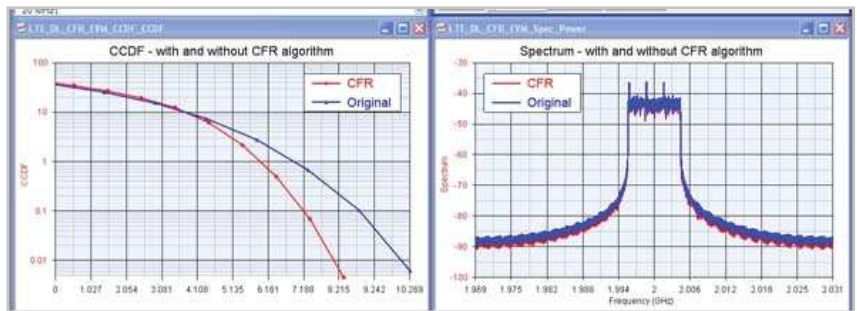

Figure 12. This LTE example evaluates a possible Crest Factor Reduction (CFR) algorithm by plotting the spectrum, CCDF, and other figures of merit for a configurable LTE DL source. Other LTE measurements, such as EVM vs. subcarrier and other channel-specific metrics, are also available. For full analytical power regarding the signal itself, simply co-simulate from SystemVue into the Agilent 89600 VSA software, and use the visualization capabilities of the instrument personality to explore the effects of algorithms and impairments even further.

LTE Testbench Samples, continued

Available LTE Testbench Examples:

C-Code Generation

- 3GPP_LTE_CFR_EVM.wsv
- 3GPP_LTE_ControlInfo_ChannelCoding.wsv
- 3GPP_LTE_DL_ChannelCoding.wsv
- 3GPP_LTE_DL_ETM.wsv
- 3GPP_LTE_DL_MIMO_Throughput.wsv
- 3GPP_LTE_DL_SISO_BER.wsv
- 3GPP_LTE_DL_Tx.wsv
- 3GPP_LTE_DL_Tx_Beamforming.wsv
- 3GPP_LTE_DL_TxEVM.wsv
- 3GPP_LTE_SignalDownload.wsv
- 3GPP_LTE_UL_BER.wsv
- 3GPP_LTE_UL_ChannelCoding.wsv
- 3GPP_LTE_UL_PRACH_Detection.wsv
- 3GPP_LTE_UL_SIMO_Throughput.wsv
- 3GPP_LTE_UL_SISO_Throughput.wsv
- 3GPP_LTE_UL_TX.wsv
- 3GPP_LTE_UL_TxEVM.wsv

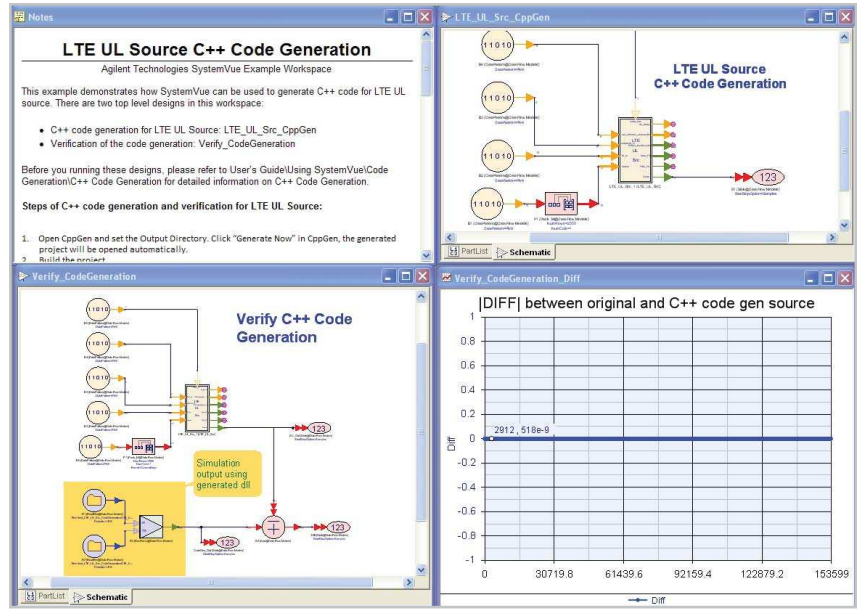

Figure 13. The LTE library (release 8/9) supports C++ code generation to create compiled Win32 DLLs that can be used in other verification environments, outside SystemVue. Your W1910/W1918 license continues to enable these executable models, even outside SystemVue.

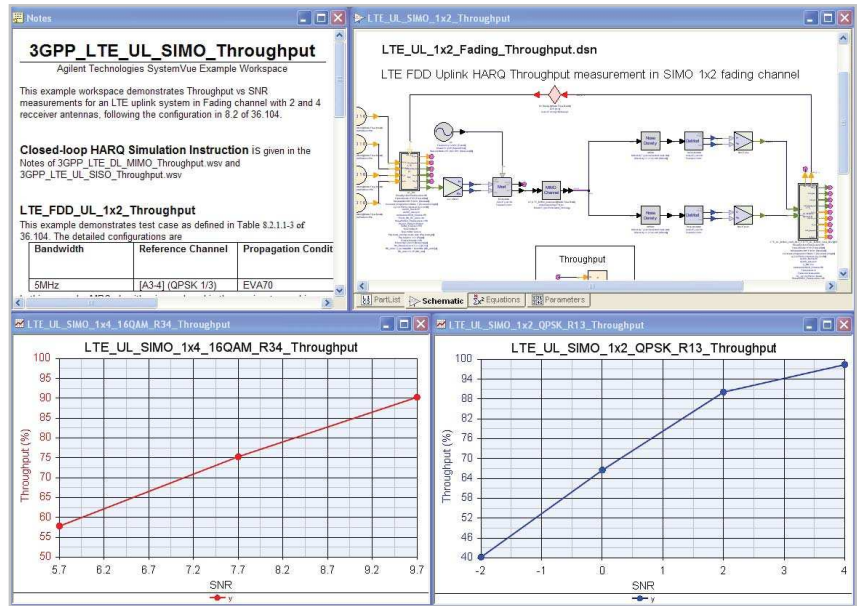

Figure 14. SystemVue 2009 introduced the "Dynamic Dataflow" simulation capability to enable true, faded throughput measurements. Dynamic Dataflow allows the data rate, and therefore the radio modulation format, to change dynamically during the simulation, while maintaining the timing and carrier frequency information needed for accurate RF and channel effects. This quasi-MAC behavior achieves both simulation behavior and physical layer accuracy that many other dataflow and event-driven simulators cannot manage simultaneously.

LTE Testbench Samples, continued

Available LTE Testbench Examples:

- 📁 C-Code Generation
- 📁 3GPP_LTE_CFR_EVM.wsv
- 📁 3GPP_LTE_DL_ChannelCoding.wsv
- 📁 3GPP_LTE_DL_ETM.wsv
- 📁 3GPP_LTE_DL_FDD_TestCase.wsv
- 📁 3GPP_LTE_DL_MIMO_Throughput.wsv
- 📁 3GPP_LTE_DL_SISO_BER.wsv
- 📁 3GPP_LTE_DL_Tx.wsv
- 📁 3GPP_LTE_DL_TxEVM.wsv
- 📁 3GPP_LTE_SignalDownload.wsv
- 📁 3GPP_LTE_UL_BER.wsv
- 📁 3GPP_LTE_UL_ChannelCoding.wsv
- 📁 3GPP_LTE_UL_PRACH_Detection.wsv
- 📁 3GPP_LTE_UL_SIMO_Throughput.wsv
- 📁 3GPP_LTE_UL_SISO_Throughput.wsv
- 📁 3GPP_LTE_UL_TX.wsv
- 📁 3GPP_LTE_UL_TxEVM.wsv

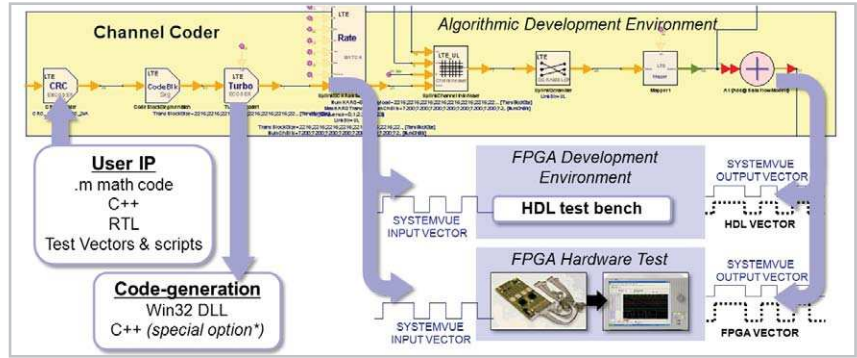

Figure 15. This LTE Channel Coding example exposes the internal signal processing chain, allowing for test vector generation and comparison from any node in the system. This facilitates easy scripting and verification of user algorithms.

3GPP_LTE_UL_PRACH_Detection (from 8.4.2 of TS 36.104)
Agilent Technologies SystemVue Example Workspace

This example workspace demonstrates PRACH detection measurements for an LTE uplink in fading and AWGN environment, following 8.4.2 of 36.104. Three example designs are provided.

LTE_FDD_PRACH_Format0_ETU70_AutoDetection
This example demonstrates test case as defined in Table 8.4.2.1-1 of 36.104. The detailed configurations are

Number of RX antennas	Propagation conditions (Annex B)	Frequency offset	SNR [dB]
2	ETU 70	270 Hz	-8.0

Burst format 0
According to 36.104, the probability of detection shall be equal to or exceed 99% for the SNR level above.

LTE_FDD_PRACH_Format1_AWGN_AutoDetection
This example demonstrates test case [1.1] as defined in Table 8.4.2.1-1 of 36.104. The detailed configurations are

Number of RX antennas	Propagation conditions (Annex B)	Frequency offset	SNR [dB]
4	AWGN	0	-16.7

Burst format 1

LTE: FDD PRACH Detection on SIMO 1x4 AWGN Channel

The schematic diagram shows a 'PRACH Source' feeding into an 'RF AWGN Channel' with four parallel paths, which then leads to a 'PRACH Detection' block.

Figure 16. This LTE example runs a standards-based Physical Random Access Channel (PRACH) Detection test that is specified in TS 36.104 of the 3GPP LTE 8.9 standard. The PRACH channel should be detected more than 99% of the time under certain specified conditions, such as S/N ratio. Pre-built testbenches like these save scripting and verification time for the engineer who must validate raw algorithms against the LTE standard.

For more information about SystemVue, please visit us on the web:

Product information

<http://www.agilent.com/find/eesof-systemvue-lte-advanced>

Product Configurations

<http://www.agilent.com/find/eesof-systemvue-configs>

Request a 30-day Evaluation

<http://www.agilent.com/find/eesof-systemvue-evaluation>

Downloads

<http://www.agilent.com/find/eesof-systemvue-latest-downloads>

Helpful Videos

<http://www.agilent.com/find/eesof-systemvue-videos>

Technical Support Forum

<http://www.agilent.com/find/eesof-systemvue-forum>



Agilent Email Updates

www.agilent.com/find/emailupdates

Get the latest information on the products and applications you select.

Windows is U.S. registered trademarks of Microsoft Corporation.

For more information on Agilent Technologies' products, applications or services, please contact your local Agilent office. The complete list is available at:

www.agilent.com/find/contactus

Americas

Canada	(877) 894 4414
Brazil	(11) 4197 3600
Mexico	01800 5064 800
United States	(800) 829 4444

Asia Pacific

Australia	1 800 629 485
China	800 810 0189
Hong Kong	800 938 693
India	1 800 112 929
Japan	0120 (421) 345
Korea	080 769 0800
Malaysia	1 800 888 848
Singapore	1 800 375 8100
Taiwan	0800 047 866
Other AP Countries	(65) 375 8100

Europe & Middle East

Belgium	32 (0) 2 404 93 40
Denmark	45 45 80 12 15
Finland	358 (0) 10 855 2100
France	0825 010 700*
	*0.125 €/minute
Germany	49 (0) 7031 464 6333
Ireland	1890 924 204
Israel	972-3-9288-504/544
Italy	39 02 92 60 8484
Netherlands	31 (0) 20 547 2111
Spain	34 (91) 631 3300
Sweden	0200-88 22 55
United Kingdom	44 (0) 118 927 6201

For other unlisted countries:

www.agilent.com/find/contactus

Revised: January 6, 2012

Product specifications and descriptions in this document subject to change without notice.

© Agilent Technologies, Inc. 2011-2012
Published in USA, January 12, 2012
5990-8135EN

