

6610C Series Single-Output, 40-50 W GPIB Power Supplies

Data Sheet

Speed and accuracy for test optimization



- Small, compact size for bench and system use
- Fast, low-noise outputs
- Dual-range, precision low current measurement
- Built-in measurements and advanced programmable features
- Protection features to ensure DUT safety

This series of linear-regulated 40-50 W DC power supplies is designed to maximize the throughput of DUTs through the manufacturing test process with fast programming and measurement, and also active downprogramming. It offers many advanced programmable features including stored states and status reporting. Programming is done using industry standard SCPI commands via the GPIB or RS-232. Test system integration is further simplified by using the *VXIplug&play* drivers. The optional relays simplify system design and troubleshooting.

The half-rack size of the 6610C series makes it a convenient DC power supply for the R&D lab bench. The built-in microamp measurement system helps the engineer to easily and accurately monitor the output voltage and current without a complicated test setup.



Agilent Technologies

Supplemental characteristics for all model numbers

DC floating voltage: Output terminals can be floated up to ± 240 VDC maximum from chassis ground

Remote sensing: Up to two volts dropped in each load lead. Add 2 mV to the voltage load regulation specification for each one volt change in the positive output lead due to load current change.

Command processing time: Average time required for the output voltage to begin to change following receipt of digital data is 4 ms for the power supplies connected directly to the GPIB.

Output programming response time: The rise and fall time (10/90% and 90/10%) of the output voltage is less than 2 ms. The output voltage change settles within 1 LSB (0.025% x rated voltage) of final value in less than 6 ms.

GPIB interface capabilities: IEEE-488.2, SCPI command set, and 6610A/B Series programming compatibility

Input power: (full load): 1.6 A, 100 W (6611C: 2.2 A, 120 W)

Regulatory compliance: Complies with EMC directive 89/336/EEC (ISM 1B).

Software driver: *VXIplug&play*

Size: 212.8 mm W x 88.1 mm H x 368.3 mm D (8.4 in x 3.5 in x 14.5 in)

Weight: 8.2 kg (18.16 lb) net; 10.6 kg (23.5 lb) shipping

Warranty: One year

Agilent models: 6611C, 6612C, 6613C, 6614C, 6611C-J05

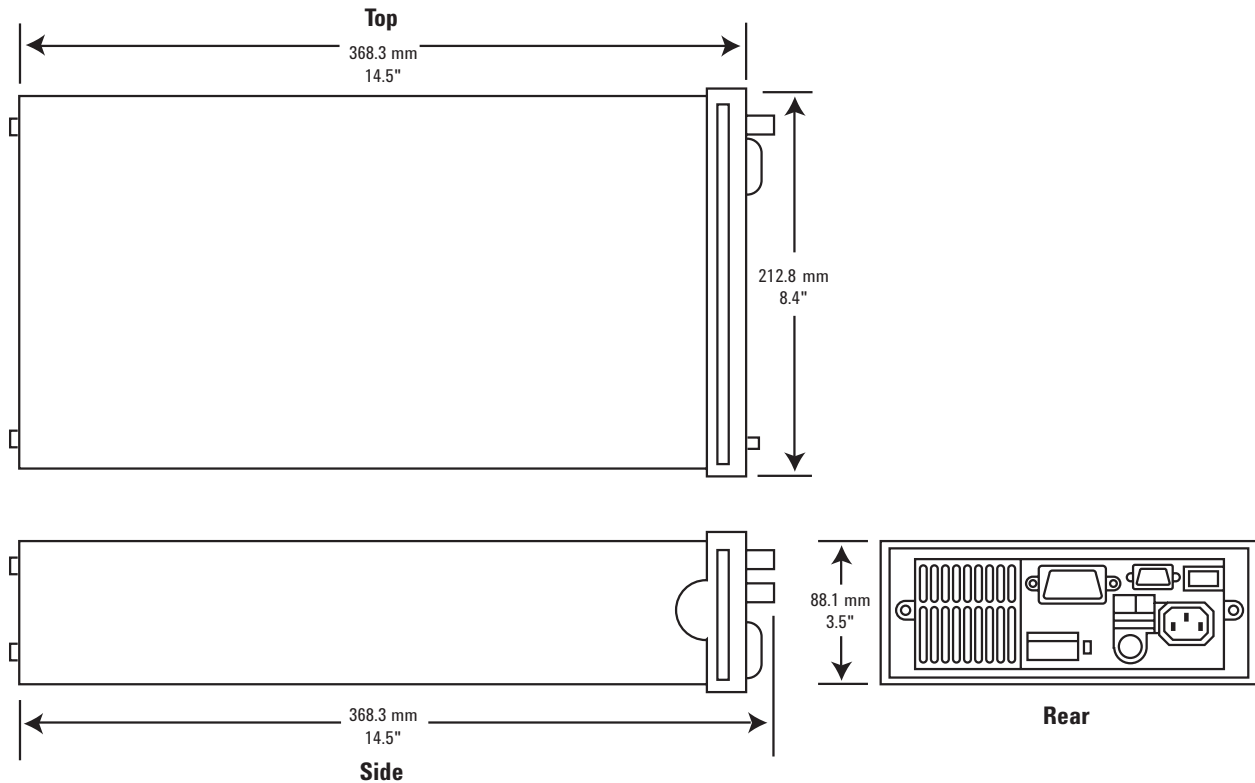

Ordering information

Opt 100 87 to 106 VAC, 47 to 63 Hz
Opt 120 104 to 127 VAC, 47 to 63 Hz
Opt 220 191 to 233 VAC, 47 to 63 Hz
Opt 230 207 to 253 VAC, 47 to 63 Hz
Opt 760 Isolation and reversal relays
Opt 87J Removes feet for use in rack system

Opt 0L1 Full documentation on CD-ROM, and printed standard documentation package. CD-ROM includes User's Guide, Programming Guide, Service Manual and Quick Start Guide
Opt 0B3 Printed service manual

Accessories

p/n 1494-0015 Rack slide kit
E3663AC Support rails for Agilent rack cabinets
1CM002A* Rack mount flange kit 88.1 mm H (2U), 1.5 inch hole space for side by side mounting of two units. Requires lock link kit (and support rails)
5061-9694 Lock link kit
1CM024A* Rack mount flange kit 88.1 mm H (2U), one bracket, one half-module bracket, and filler panel

Application notes

10 Practical Tips You Need to Know About Your Power Products, 5965-8239E

10 Hints for Using Your Power Supply to Decrease Test Time, 5968-6359E

Understanding Linear Power Supply Operation (AN1554), 5989-2291EN

* Support rails required



Agilent Advantage Services is committed to your success throughout your equipment's lifetime. To keep you competitive, we continually invest in tools and processes that speed up calibration and repair and reduce your cost of ownership. You can also use Infoline Web Services to manage equipment and services more effectively. By sharing our measurement and service expertise, we help you create the products that change our world.

www.agilent.com/find/advantageservices



Agilent Email Updates

www.agilent.com/find/emailupdates
Get the latest information on the products and applications you select.

Agilent Channel Partners

www.agilent.com/find/channelpartners
Get the best of both worlds: Agilent's measurement expertise and product breadth, combined with channel partner convenience.

For more information on Agilent Technologies' products, applications or services, please contact your local Agilent office. The complete list is available at: www.agilent.com/find/contactus

Americas

Canada	(877) 894 4414
Brazil	(11) 4197 3600
Mexico	01800 5064 800
United States	(800) 829 4444

Asia Pacific

Australia	1 800 629 485
China	800 810 0189
Hong Kong	800 938 693
India	1 800 112 929
Japan	0120 (421) 345
Korea	080 769 0800
Malaysia	1 800 888 848
Singapore	1 800 375 8100
Taiwan	0800 047 866
Other AP Countries	(65) 375 8100

Europe & Middle East

Belgium	32 (0) 2 404 93 40
Denmark	45 45 80 12 15
Finland	358 (0) 10 855 2100
France	0825 010 700* *0.125 €/minute
Germany	49 (0) 7031 464 6333
Ireland	1890 924 204
Israel	972-3-9288-504/544
Italy	39 02 92 60 8484
Netherlands	31 (0) 20 547 2111
Spain	34 (91) 631 3300
Sweden	0200-88 22 55
United Kingdom	44 (0) 118 927 6201

For other unlisted countries:

www.agilent.com/find/contactus

Revised: January 6, 2012

Product specifications and descriptions in this document subject to change without notice.

© Agilent Technologies, Inc. 2012
Published in USA, February 7, 2012
5990-9301EN

