

6550A Series Single-Output, 500 W DC Power Supplies

Data Sheet

Speed and accuracy for test optimization



- Front panel and analog control of output voltage and current
- Fast, low-noise outputs
- Fan-speed control to minimize acoustic noise
- Protection features to ensure DUT safety

This reliable series of 500 W DC power supplies can be controlled either from the front panel or via an analog programming voltage. When used in a test system, the fast up and down programming helps decrease test time. Quickly reacting protection features, including fast crowbar, CV/CC mode crossover and over-voltage protection help protect your valuable assemblies from damage. The linear topology produces very low ripple and noise, which allows you to make extremely accurate measurements of the devices which you are testing.

Lab bench use is enhanced by the fan speed control, which helps to minimize acoustic noise.



Agilent Technologies

Specifications

Specifications <i>(at 0 ° to 55 °C unless otherwise specified)</i>	6551A	6552A	6553A	6554A	6555A
Number of outputs	1	1	1	1	1
GPIB	No	No	No	No	No
Output ratings					
Output voltage	0 to 8 V	0 to 20 V	0 to 35 V	0 to 60 V	0 to 120 V
Output current (40 °C)	0 to 50 A	0 to 25 A	0 to 15 A	0 to 9 A	0 to 4 A
Maximum current (50 °C/55 °C)	45 A/42.5 A	22.5 A/21.3 A	13.5 A/12.8 A	8.1 A/7.7 A	3.6 A/3.4 A
Programming accuracy (at 25 °C ± 5 °C)					
Voltage 0.06% +	5 mV	10 mV	15 mV	26 mV	51 mV
Current 0.15% +	60 mA	25 mA	13 mA	8 mA	4 mA
Ripple and noise from 20 Hz to 20 MHz					
Voltage rms	300 µV	300 µV	400 µV	500 µV	700 µV
peak-to-peak	3 mV	3 mV	4 mV	5 mV	7 mV
Current rms	25 mA	10 mA	5 mA	3 mA	2 mA
Load regulation					
Voltage	1 mV	2 mV	3 mV	4 mV	5 mV
Current	2 mA	1 mA	0.5 mA	0.5 mA	0.5 mA
Line regulation					
Voltage	0.5 mV	0.5 mV	1 mV	1 mV	2 mV
Current	2 mA	1 mA	0.75 mA	0.5 mA	0.5 mA

Transient response time

Less than 100 µs for the output voltage to recover to its previous level (within 0.1% of the voltage rating of the supply or 20 mV, whichever is greater) following any step change in load current of up to 50% of the output current rating of the supply

Supplemental characteristics <i>(Non-warranted characteristics determined by design and useful in applying the product)</i>	6551A	6552A	6553A	6554A	6555A
Average resolution					
Voltage	2 mV	5 mV	10 mV	15 mV	30 mV
Current	15 mA	7 mA	4 mA	2.5 mA	1.25 mA
OVP	12 mV	30 mV	54 mV	93 mV	190 mV
OVP accuracy	160 mV	400 mV	700 mV	1.2 V	2.4 V

Specifications, continued

Specifications <i>(at 0 ° to 55 °C unless otherwise specified)</i>	6554A-J04 Special order option	6554A-J05 Special order option	6554A-J12 Special order option	6555A-J10 Special order option
Number of outputs	1	1	1	1
GPIB	No	No	No	No
Output ratings				
Output voltage	70 V	50 V	80 V	156 V
Output current (40 °C)	7.5 V	10 A	6 A	3 A
Maximum current (50 °C/55 °C)	6.75 A/6.37 A	9 A/8.5 A	5.4 A/5.1 A	2.7 A/2.55 A
Programming accuracy (at 25 °C ± 5 °C)				
Voltage 0.06% +	38 mV	26 mV	35 mV	71 mV
Current 0.15% +	7 mA	9 mA	7 mA	4 mA
Ripple and noise from 20 Hz to 20 MHz				
Voltage rms	600 µV	500 µV	700 µV	900 µV
peak-to-peak	6 mV	5 mV	5 mV	8 mV
Current rms	5 mA	4 mA	3 mA	3 mA
Load regulation				
Voltage	4 mV	4 mV	4 mV	7 mV
Current	0.5 mA	0.5 mA	0.5 mA	1 mA
Line regulation				
Voltage	1 mV	1 mV	4.5 mV	2 mV
Current	0.5 mA	0.5 mA	0.5 mA	1 mA
Transient response time	Less than 100 µs for the output voltage to recover to its previous level (within 0.1% of the voltage rating of the supply or 20 mV, whichever is greater) following any step change in load current of up to 50% of rated current			
Supplemental characteristics <i>(Non-warranted characteristics determined by design and useful in applying the product)</i>	6554A-J04 Special order option	6554A-J05 Special order option	6554A-J12 Special order option	6555A-J10 Special order option
Average resolution				
Voltage	17.5 mV	15 mV	20 mV	39.5 mV
Current	1.9 mA	2.75 mA	1.7 mA	8 mA
OVP	110 mV	93 mV	130 mV	250 mV
OVP accuracy	1.4 V	1.2 V	1.6 V	3.3 V

Supplemental characteristics for all model numbers

DC floating voltage: Output terminals can be floated up to ± 240 VDC from chassis ground

Remote sensing: Up to half the rated output voltage can be dropped in each load lead. The drop in the load leads subtracts from the voltage available for the load.

Output programming response time: The rise and fall time (10/90% and 90/10%) of the output voltage is less than 15 ms. The output voltage change settles within 1 LSB (0.025% x rated voltage) of final value in less than 60 ms.

Down programming: An active down programmer sinks approximately 20% of the rated output current

Modulation: (Analog programming of output voltage and current)

Input signal: 0 to -5 V

Input impedance: 10 kΩ nominal

AC input:

(AC input frequency 47 to 63 Hz)

Voltage	100 VAC	120 VAC	220 VAC	240 VAC
Current	12 A	10 A	5.7 A	5.3 A

Input power: 1,380 VA, 1,100 W at full load; 120 W at no load

Regulatory compliance: Listed to UL 1244; certified to CSA556B; conforms to IEC 61010-1

Size:

425.5 mm W x 132.6 mm H x 497.8 mm D
(16.75 in x 5.22 in x 19.6 in)

Weight: Net, 25 kg (54 lb); shipping, 28 kg (61 lb)

Warranty: One year

Agilent models: 6551A, 6552A, 6553A, 6554A, 6555A

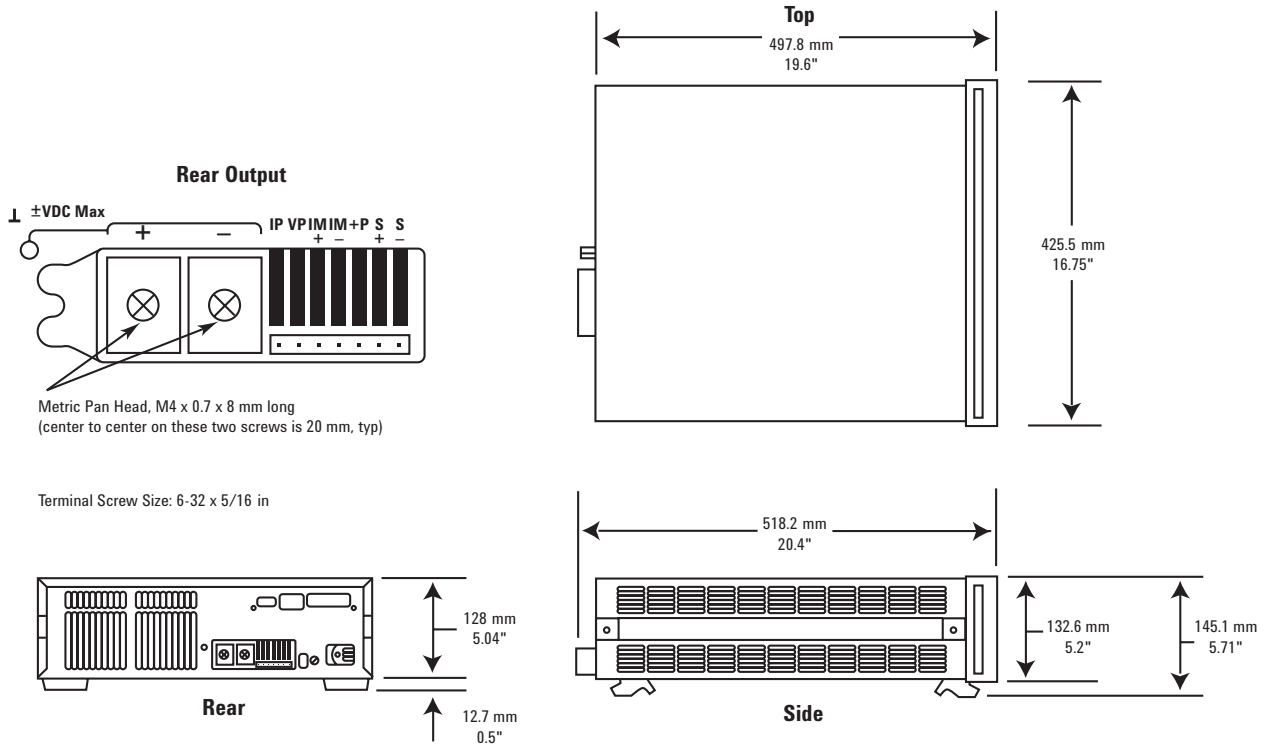

Ordering information

Opt 100 87 to 106 VAC, 47 to 63 Hz
Opt 120 104 to 127 VAC, 47 to 63 Hz
Opt 220 191 to 233 VAC, 47 to 63 Hz
Opt 240 209 to 250 VAC, 47 to 63 Hz

Opt 0L1 Full documentation on CD-ROM and printed user's guide. CD-ROM includes user's guide, service manual, and quick start guide
Opt 0B3 Printed service manual

Accessories

1CM003A* Rack mount flange kit 132.6 mm H (3U) – two flange brackets
1CP002A* Rack mount flange and handle kit 132.6 mm H (3U) – two brackets and front handles
E3663AC Support rails for Agilent rack cabinets
p/n 1494-0059 Accessory slide kit

Application notes

10 Practical Tips You Need to Know About Your Power Products, 5965-8239E

Understanding Linear Power Supply Operation (AN1554), 5989-2291EN

Agilent DC Power Supplies for Base Station Testing, 5988-2386EN

* Support rails required



Agilent Advantage Services is committed to your success throughout your equipment's lifetime. To keep you competitive, we continually invest in tools and processes that speed up calibration and repair and reduce your cost of ownership. You can also use Infoline Web Services to manage equipment and services more effectively. By sharing our measurement and service expertise, we help you create the products that change our world.

www.agilent.com/find/advantageservices



www.agilent.com/find/emailupdates

Get the latest information on the products and applications you select.

Agilent Channel Partners

www.agilent.com/find/channelpartners

Get the best of both worlds: Agilent's measurement expertise and product breadth, combined with channel partner convenience.

For more information on Agilent Technologies' products, applications or services, please contact your local Agilent office. The complete list is available at: www.agilent.com/find/contactus

Americas

Canada	(877) 894 4414
Brazil	(11) 4197 3600
Mexico	01800 5064 800
United States	(800) 829 4444

Asia Pacific

Australia	1 800 629 485
China	800 810 0189
Hong Kong	800 938 693
India	1 800 112 929
Japan	0120 (421) 345
Korea	080 769 0800
Malaysia	1 800 888 848
Singapore	1 800 375 8100
Taiwan	0800 047 866
Other AP Countries	(65) 375 8100

Europe & Middle East

Belgium	32 (0) 2 404 93 40
Denmark	45 45 80 12 15
Finland	358 (0) 10 855 2100
France	0825 010 700*
	*0.125 €/minute
Germany	49 (0) 7031 464 6333
Ireland	1890 924 204
Israel	972-3-9288-504/544
Italy	39 02 92 60 8484
Netherlands	31 (0) 20 547 2111
Spain	34 (91) 631 3300
Sweden	0200-88 22 55
United Kingdom	44 (0) 118 927 6201

For other unlisted countries:

www.agilent.com/find/contactus

Revised: January 6, 2012

Product specifications and descriptions in this document subject to change without notice.

© Agilent Technologies, Inc. 2012
Published in USA, February 15, 2012
5990-9299EN

