



Agilent 83036C Coaxial GaAs Directional Detector

0.01 to 26.5 GHz

Data Sheet

Features and Description

- Exceptional flatness: +1 dB
- Extremely broadband: 0.01 - 26.5 GHz
- Compact size
- Environmentally rugged

The Agilent 83036C is a broadband microwave power sampler which operates in the same fashion as a traditional coupler-detector combination, but with improved frequency response and much smaller size. The directional detector is designed to perform over the 10 MHz to 26.5 GHz frequency band with ± 1.0 dB of output voltage variation at room temperature. The directional detector is capable of operating with greater than one watt of input power when terminated with well-matched source and load impedance. An input power derating curve is provided for calculating the maximum input power for other source and load impedance.

The 83036C is comprised of a resistive bridge and a broadband planar-doped barrier (PDB) diode. The circuit is shown in Figure 1. The bridge is manufactured by depositing thin film resistors directly onto GaAs substrate material. The use of a resistive bridge as the signal-sampling device makes possible the extremely broadband device response.

The addition of a PDB diode and charging capacitor completes the GaAs bridge chip design. The PDB diode is fabricated using Agilent's proprietary modified barrier integrated diode (MBID) process which produces a detector diode with superior temperature, flatness and square law response characteristics.

An external RF bypass capacitor, DC blocking capacitors and two off-chip resistors complete the directional detector design. The input blocking capacitors are rated at 15 Vdc maximum. The complete circuit exhibits a room temperature video impedance of approximately 8000Ω . This video impedance results in a typical detector risetime of less than 2 microseconds.

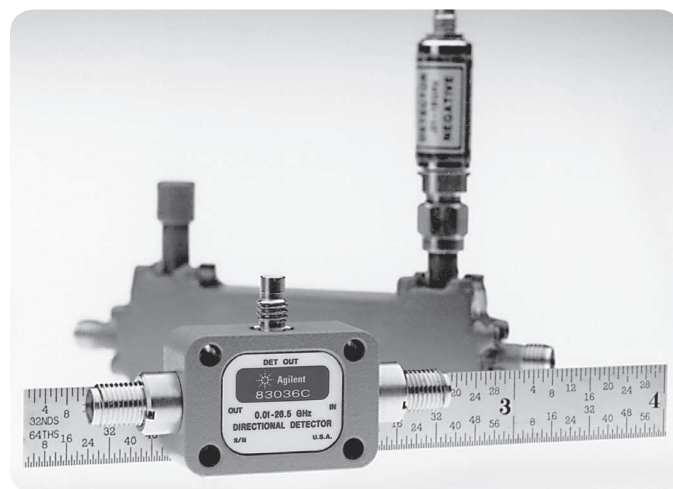

The 83036C is much smaller than the directional coupler-detector combinations which it is designed to replace. The entire unit occupies a volume of less than 0.47 cubic inches ($< 8\text{ cm}^3$) vs. a typical connectorized detector which alone can occupy more than 1 cubic inch (16.4 cm^3). The directional detector features 3.5 mm microwave connectors and an SMC connector at its dc output.

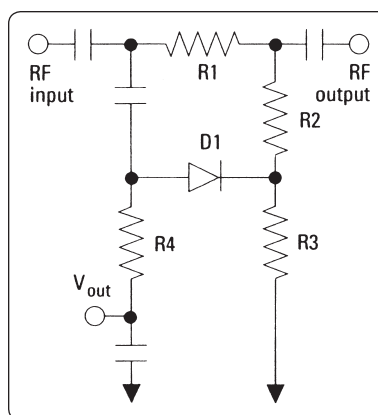

Figure 1. Bridge circuit



Agilent Technologies

Applications for the 83036C include broad band amplifier leveling circuits (Figure 2), power monitoring circuits (Figure 3), and SWR alarm circuits (Figure 4) in instrument, communication and EW applications.

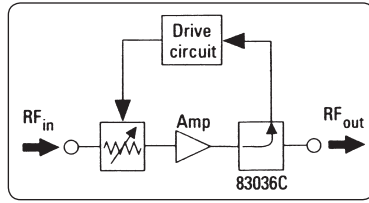

Figure 2. Amplifier leveling loop

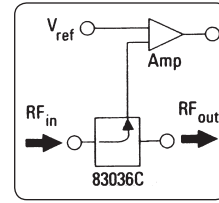

Figure 3. Forward power monitor

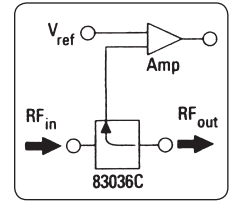

Figure 4. Reverse power monitor

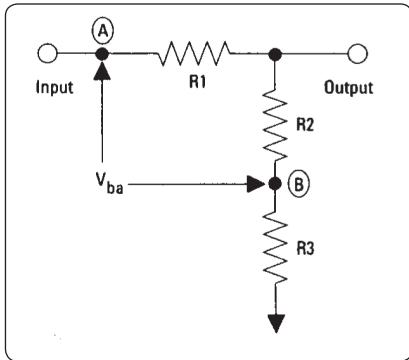

Diagram 1. Circuit approximation

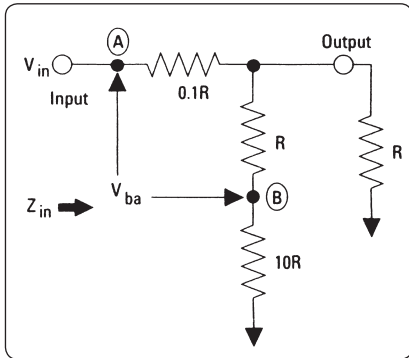

Diagram 2. Input impedance

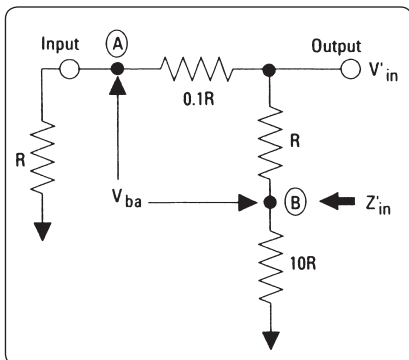

Diagram 3. Output impedance

Why A Directional Bridge?

A directional bridge is inherently a much broader band device than a directional coupler. Fabricated from thin film resistors, the directional bridge exhibits superior, repeatable performance from dc to 26.5 GHz when compared to microstrip or stripline couplers operating over the same band.

To properly separate forward signals from reverse signals, resistor values must be carefully chosen and manufactured to precision tolerances. A typical bridge configuration is shown in Figure 1. Assuming that the diode detector, D1, exhibits high input impedance over the entire frequency band, this circuit can be approximated by the circuit shown in Diagram 1. The diode voltage is determined by the voltage V_{ba} .

For a transmission line of characteristic impedance R , the bridge resistor values are chosen in the ratios shown in Diagram 2. The input impedance of the circuit and the voltage V_{ba} are then calculated as shown in Equations 1 and 2.

$$Z_{in} = R*(R + 10R)/(R + (R + 10R)) + 0.1 R \quad \text{Equation (1)}$$

$$= 1.02R \approx R$$

$$V_{ba} = (V_{in}/1.02R)*[0.1 R + (R * R) / 12R] \quad \text{Equation (2)}$$

$$= 0.18 V_{in}$$

Using the same resistor values, the output impedance of the circuit can be calculated (see Diagram 3) as can the voltage impressed between the points A and B by a signal traveling in the reverse direction. These calculations are shown in Equations 3 and 4.

$$Z'_{in} = (0.1 R + R) * (R + 10R)/[(0.1R + R) + (R + 10R)] \quad \text{Equation (3)}$$

$$= R$$

$$V_{ba} = (V'_{in}/R) * [(11R * 0.1 R)/(12.1R) - (1.1R * R)/(12.1R)] \quad \text{Equation (4)}$$

$$= 0$$

These calculations indicate that the bridge will be well matched at its input and output and, in the ideal case, will exhibit infinite directivity, i.e., a positive V_{ba} value for a forward traveling signal, $V_{ba} = 0$ for a reflected or backward traveling signal.

While the analysis given above assumes 50Ω source and load impedances, a complete analysis reveals that the directivity and coupling values of the bridge are maintained over a wide range of source and load impedances. The net result is that the 83036C is capable of maintaining an excellent source match when terminated in a wide range of output load impedances.

Typical Performance Data

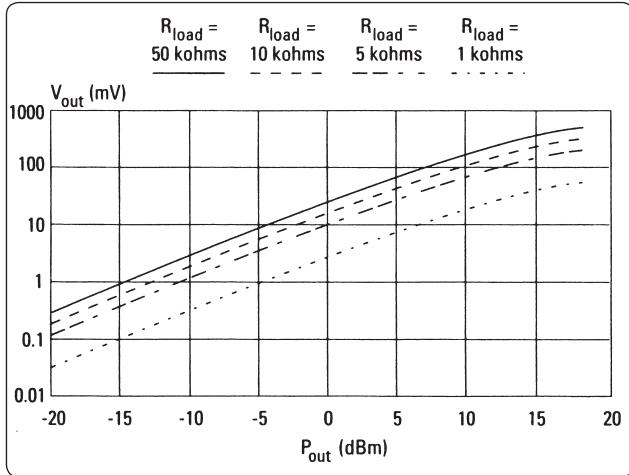

Figure 5. Typical transfer characteristic.
Frequency = 18 GHz temperature = +25 °C

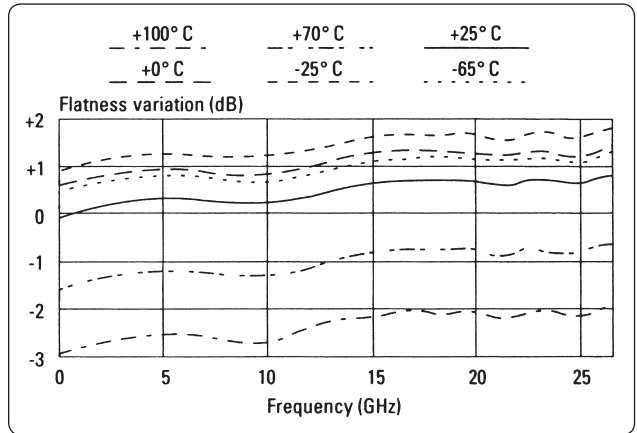

Figure 8. Typical flatness at various temperatures. $R_{load} = 100 \text{ k}\Omega$

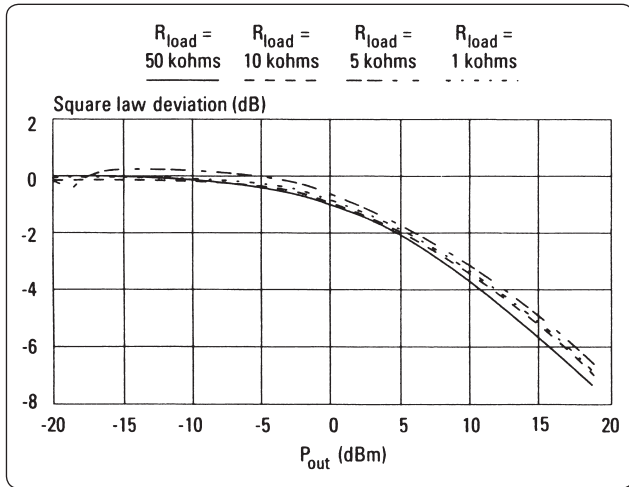

Figure 6. Typical square law deviation.
Frequency = 18 GHz temperature = +25 °C

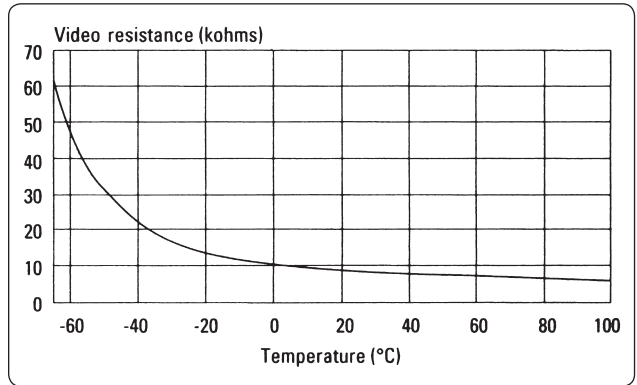

Figure 9. Typical video resistance variation with temperature.
Frequency = 18 GHz $P_{out} = -10 \text{ dBm}$

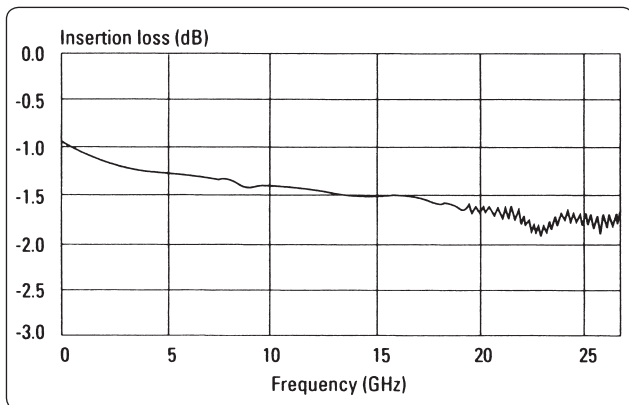

Figure 7. Typical insertion loss.

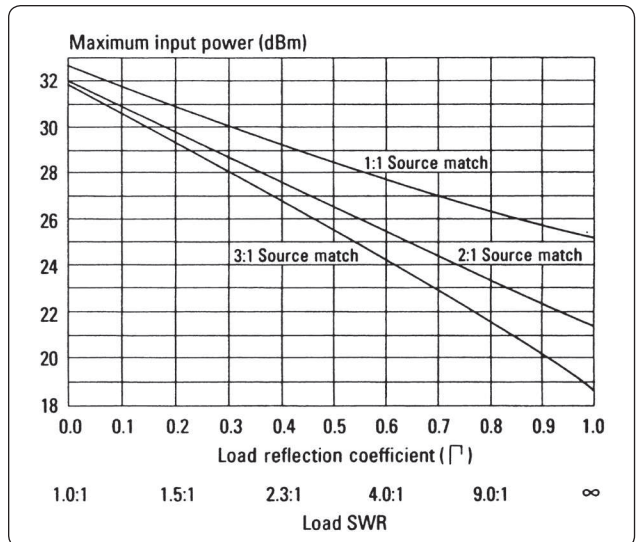

Figure 10. Maximum input power @ 25 °C.
Derate by 3 dB @ 70 °C.

Specifications at 25 °C

Frequency: 0.01 to 26.5 GHz

Loss: 2.2 dB maximum

Directivity: 14 dB minimum

Input SWR: 1.7:1 (2:1 below 50 MHz)

Output SWR: 1.7:1 (2:1 below 50 MHz)

Flatness: ±1 dB maximum

Sensitivity: 18 μV/μW minimum

Output polarity: negative

Environmental

Operating temperature: 0 to +55 °C

Non-operating temperature: -65 to +150 °C

Random vibration: in accordance with MIL-STD-883, method 2026, condition HA: 5.9 Grms, 50 to 2000 Hz.

Shock: in accordance with MIL-STD-883, method 2002.3, condition B: 1500 g for 0.5 mS.

Moisture resistance: in accordance with MIL-STD-883, method 1004.5: 10 cycles, -10 to +65 °C at 90 to 100% RH.

Altitude: in accordance with MIL-STD-883, method 1001, condition C: 50000 ft. operating altitude.

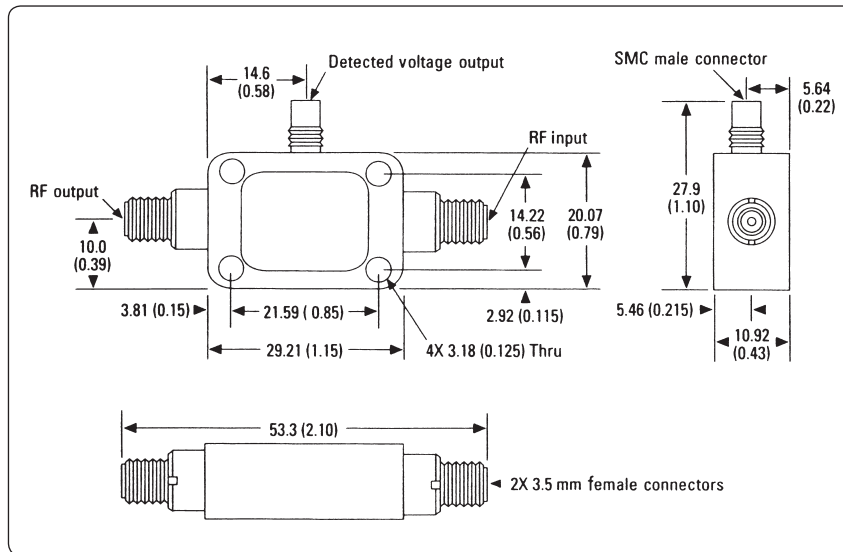

Figure 11. Dimensions in millimeters and (inches)

www.agilent.com

For more information on Agilent Technologies' products, applications or services, please contact your local Agilent office. The complete list is available at:

www.agilent.com/find/contactus

Americas

Canada	(877) 894 4414
Brazil	(11) 4197 3600
Mexico	01800 5064 800
United States	(800) 829 4444

Asia Pacific

Australia	1 800 629 485
China	800 810 0189
Hong Kong	800 938 693
India	1 800 112 929
Japan	0120 (421) 345
Korea	080 769 0800
Malaysia	1 800 888 848
Singapore	1 800 375 8100
Taiwan	0800 047 866
Other AP Countries	(65) 375 8100

Europe & Middle East

Belgium	32 (0) 2 404 93 40
Denmark	45 45 80 12 15
Finland	358 (0) 10 855 2100
France	0825 010 700*
	*0.125 €/minute
Germany	49 (0) 7031 464 6333
Ireland	1890 924 204
Israel	972-3-9288-504/544
Italy	39 02 92 60 8484
Netherlands	31 (0) 20 547 2111
Spain	34 (91) 631 3300
Sweden	0200-88 22 55
United Kingdom	44 (0) 118 927 6201

For other unlisted countries:

www.agilent.com/find/contactus

Revised: January 6, 2012

Product specifications and descriptions in this document subject to change without notice.

© Agilent Technologies, Inc. 1990-2012
Published in USA, May 16, 2012
5952-1874



Agilent Technologies