

Agilent N4917A Optical Receiver Stress Test Solution

Data Sheet Version 1.3

New: Extension to 8G Fibre Channel

Repeatable optical receiver stress tests according to 10GbE IEEE 802.3ae, 8GFC and 10GFC standards

- Targets 10 GbE -LR/ -ER / -SR, 8GFC, 10GFC
- One E/O reference transmitter for 1310 nm and 1550 nm, single mode and one for 850 nm, multi mode
- One O/E reference receiver for 750 nm to 1640 nm, single mode and multi mode
- Data rates at standard's target and up to 14.2 Gb/s in reference transmitter mode
- Automation and adjustments included in the software
- Conformance tests and characterization
- Adjustable ER, OMA, sinusoidal interference (SI), periodic jitter (PJ)
- Jitter tolerance and receiver sensitivity (BER vs OMA) result screens
- Repeatable results



Optical reference transmitter and receiver stress test solution



Optical Receiver Stress Test

The calibrated optical receiver stress test solution provides accurate signal stress for receiver tolerance and compliance testing. It is available for the popular standards of 10 Gb Ethernet IEEE 802.3ae for -LR, -ER, -SR, and for 8G and 10G Fibre Channel. The parameters of ER, OMA, SI and PJ are calibrated and can be dialed so VECP and total jitter can be precisely set.

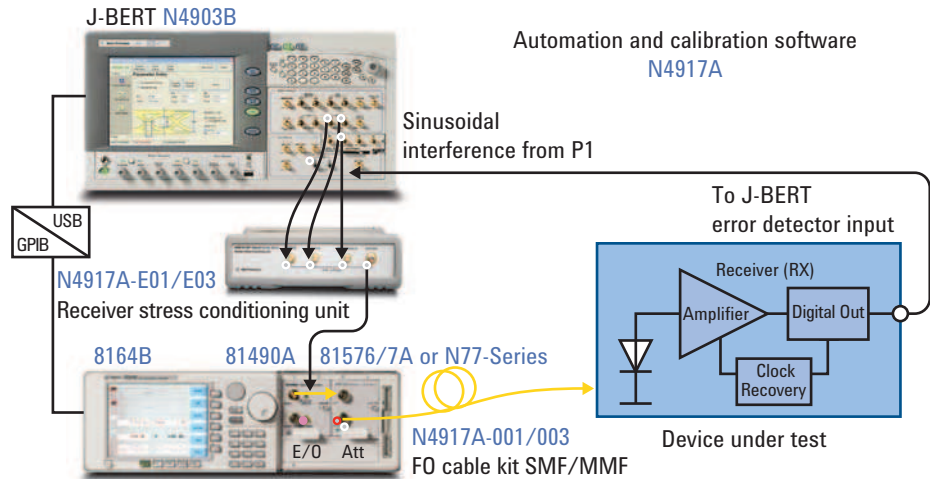

Figure 1. Optical receiver stress test setup for 10GbE and 10GFC standards

The stress signal is generated from the J-BERT N4903B with help of the N4917A-E01 receiver stress conditioning unit. The output of the N4917A-E01/-E03 drives the 81490A optical reference transmitter, which connects to the 81576A or N77-Series optical attenuator. The output of the optical attenuator connects to the device under test (DUT). The DUT electrical output connects to the J-BERT N4903B error detector input.

This closes the loop for BER measurement, which is the base for the highest level measurements of receiver sensitivity or jitter tolerance. If the DUT output is available only as optical signal, the conversion of the optical signal for electrical BER measurement can be performed with the help of the 81495A reference receiver, which can be added to the setup, but is not mandatory.

Optical Receiver Stress Test

For 8GFC the receiver stress test setup is slightly different as shown in Figure 2. A compliant stress conditioning can be achieved with J-BERT's built-in ISI traces.

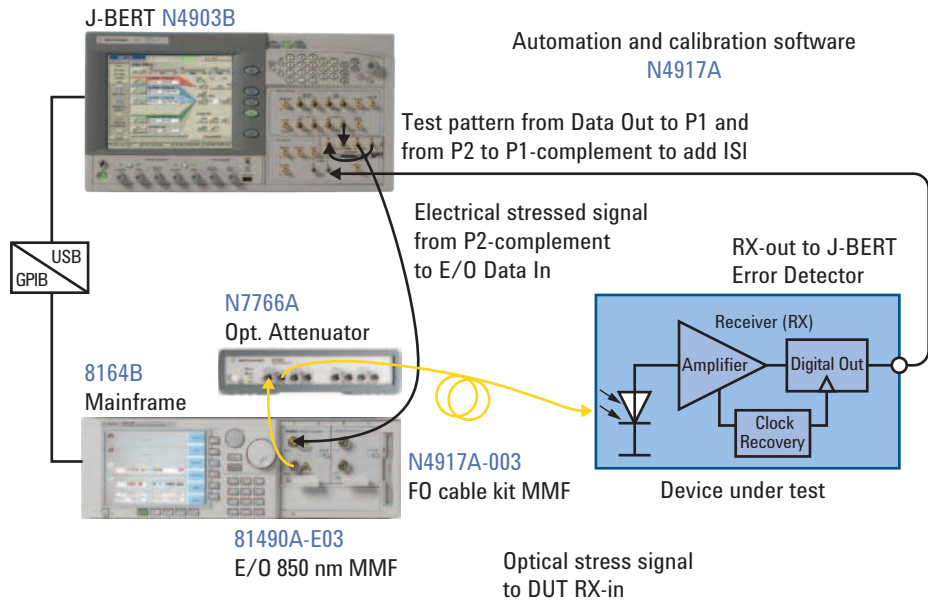

Figure 2. Optical receiver stress test setup for 8GFC

10 GbE/10GFC/8GFC stressed eye test signals

Table 1. Stressed eye signal impairment resources

	Stressed eye signal	Required	Notes
Jitter	Sinusoidal jitter (SJ)	Yes	Provided by J-BERT N4903B
	Random jitter (RJ)	Optional	
Amplitude impairments	Sinusoidal interference (SI)	Yes	Provided by J-BERT N4903B and N4917A-E01/ -E03 receiver stress conditioning unit
	Intersymbol interference (ISI)	Yes	

User Interface

The N4917A software runs on a PC with Windows® XP or Windows 7 (32 bit only). It controls the instrument setup over a USB to GPIB interface.

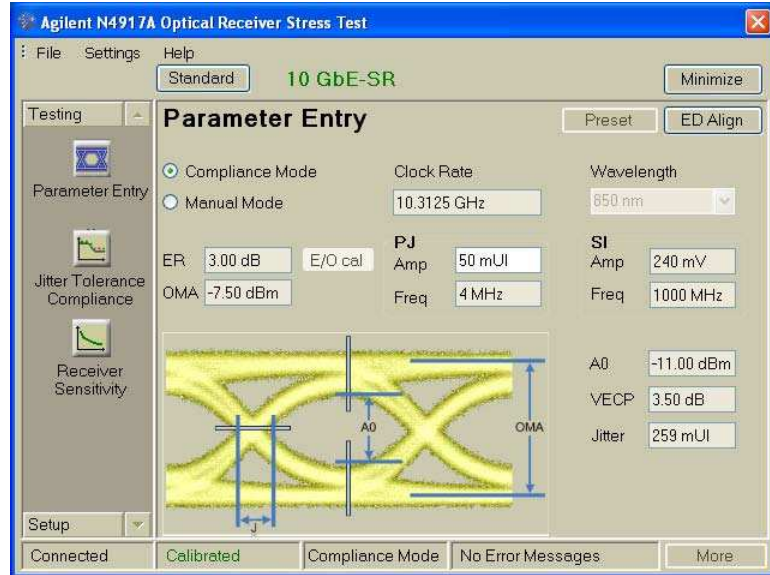

Figure 3. Parameter entry for ER, OMA, PJ and SI. For the defined standards the values for A0, VECP and total jitter will be displayed.

The user interface operates the instruments interactively, runs the compliance test automating various measurements (such as jitter tolerance) and controls the instrument's setup and calibration. Interactive operation lets the user vary the optical parameters using dials. The automated measurements provide the generation of a report file.

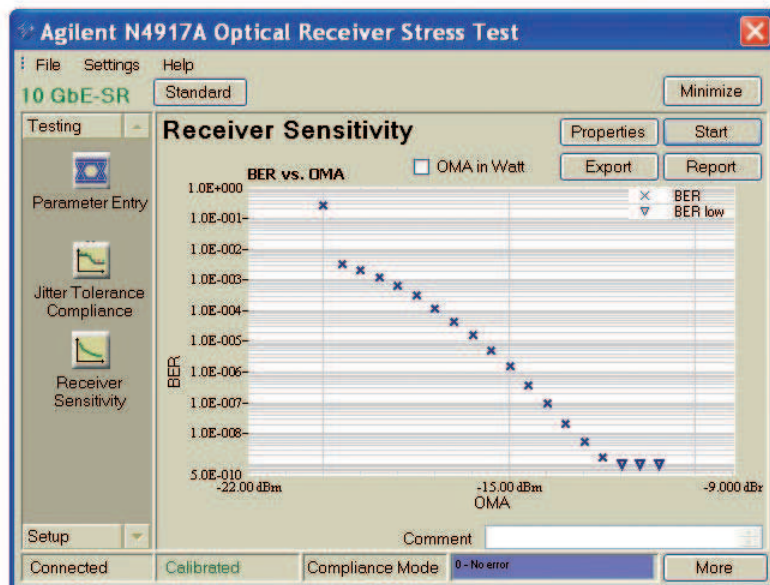
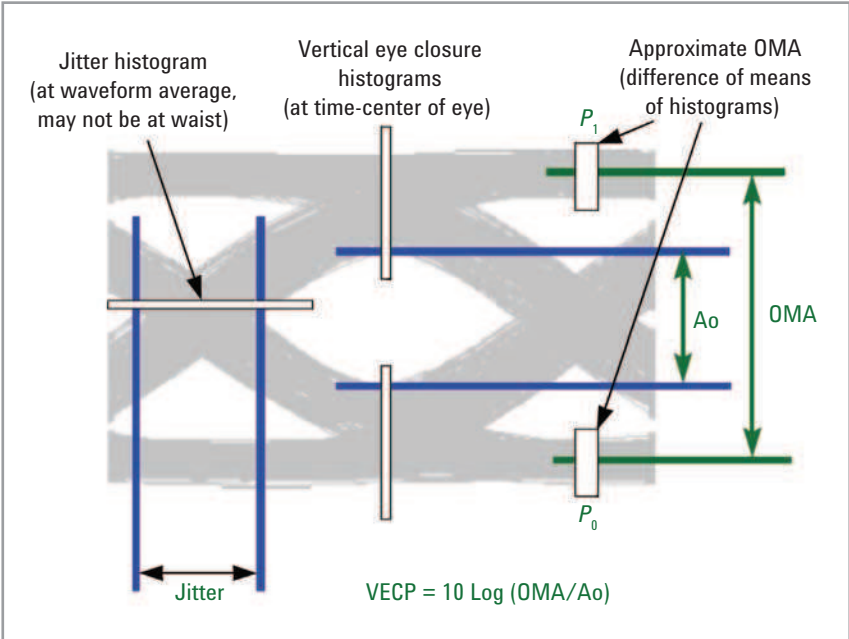

Figure 4. Jitter receiver sensitivity compliance measurement

Definitions

Optical receiver stress is defined by a compliance eye and a jitter tolerance curve (the standard calls it "mask")



F Definition of OMA, A_0 and VECP according IEEE 802.ae, clause 52

Applied sinusoidal jitter peak-to-peak amplitude (UI)

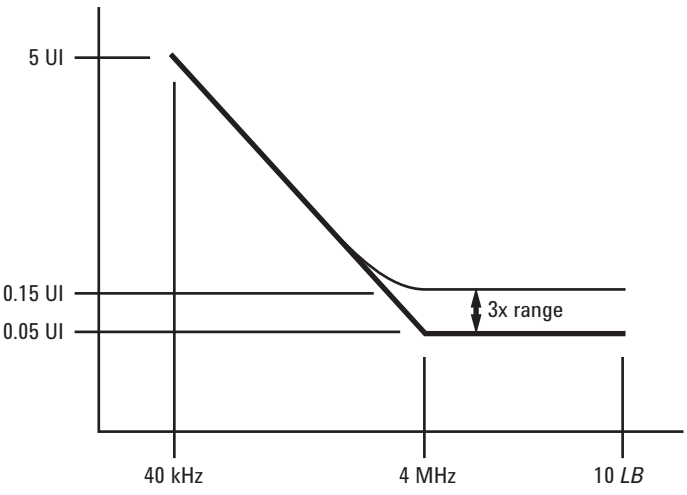

Figure 6. Jitter tolerance curve for 10 GBASE-LR/-ER/-SR and 10GFC

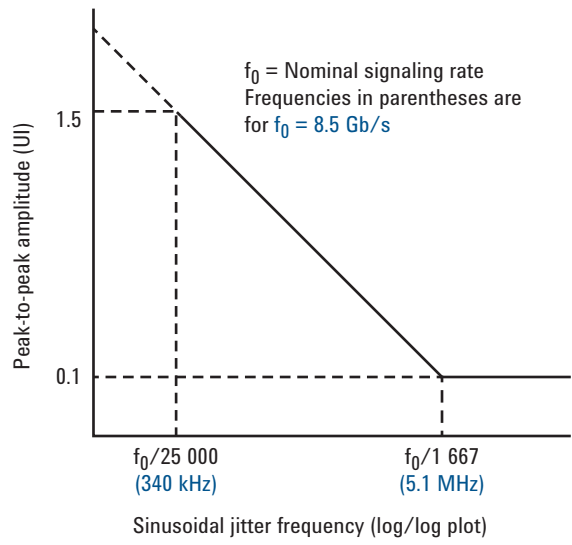

Figure 7. Jitter tolerance curve for 8GFC receiver test

Specifications



F
o
co

Ta

Optical wavelength	1310 nm and 1550 nm	850 nm
Optical fiber	Single-mode fiber (SMF) 9/125 μ m	Multimode fiber (MMF) 50/125 μ m
Extinction ratio	Adjustable from 1.5 to 10.0 dB @ 1310 nm, 1.5 to 7.5 dB @ 1550 nm	Adjustable from 1.5 to 7.5 dB @ 850 nm
OMA	Up to -5 dBm (0.32 mW) ¹ @ ER = 3 dB, adjustable 0 to -60 dB by 0.01 dB	Up to -5 dBm (0.32 mW) @ ER = 3 dB, adjustable 0 to -35 dB by 0.05 dB
VECP from filter (no jitter added)	1.5 dB typical at ER = 3	2.0 dB typical at ER = 3
Eye mask margin, according to IEEE 802.3ae Clause 52 definition	0.15 UI typical	0.15 UI typical
Random jitter	1 ps rms typical	1.5 ps rms typical
Periodic jitter (PJ)	According Periodic and Sinusoidal Jitter of N4903B -J10	According Periodic and Sinusoidal Jitter of N4903B -J10
Sinusoidal interference (SI)	0 to 400 mV @ 500 MHz to 3.2 GHz, 1 MHz resolution; VECPmax 7 dB typical at ER = 3	0 to 400 mV @ 500 MHz to 3.2 GHz, 1 MHz resolution; VECPmax 7 dB typical at ER = 3
Repeatability of the sensitivity measurement	0.5 dB typical	0.5 dB typical

Footnote 1. Up to -0 dBm (1 mW) @ ER = 3 dB, adjustable 0 to -60 dB by 0.01 dB when using 86105B/D

Specification assumption

The specifications in this document describe the solution's warranted performance. Non-warranted values are described as typical. More specifications are available in the data sheets of the individual instruments (N4903B, 81490A, 81576A, N77-Series). All specifications are valid after a warm-up phase as specified for the individual instruments. If not otherwise stated, all electrical inputs and outputs need to be terminated with 50 Ω to ground. All specifications, if not otherwise stated, are using the recommended N4917A accessories.

For the verification of the specifications a 86100C/D wide- bandwidth oscilloscope with 86105B/C/D optical module is recommended. A PRBS pattern of 2¹¹-1 is recommended if not otherwise stated. For the measurement of ER the use of the extinction ratio correction factor is recommended ¹. For the measurement of OMA a pattern of ..1100.. is recommended. For the measurement of RJ the use of the 86107A precision timebase module is recommended, which is not mandatory for the N4917A setup.

Typical Signals Provided by the Optical Receiver Stress Test Solution

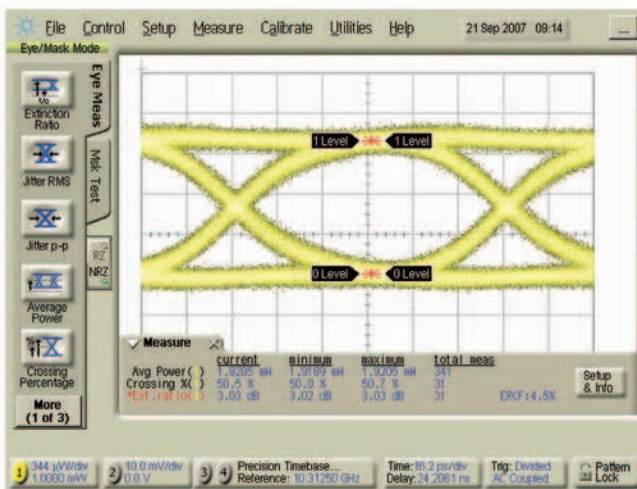

Figure 9. Eye diagram of the optical signal using the N4917A-E01 without any additional jitter added, measurement of ER and crossing point (PRBS $2^{11}-1$ pattern)

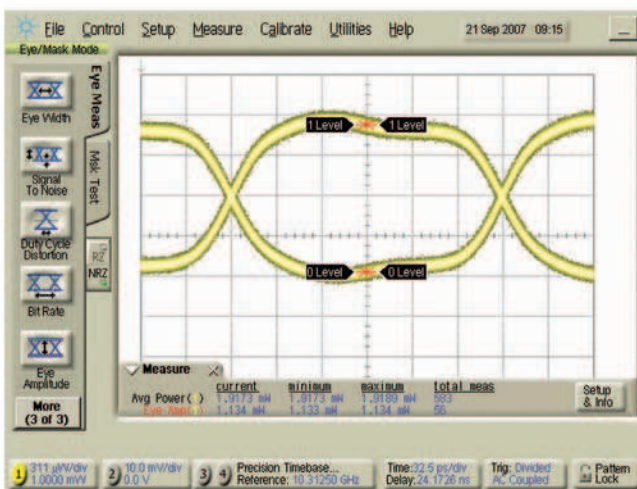

Figure 10. Eye diagram of the optical signal using the N4917A-E01 without any jitter added, measurement of OMA (..1100.. pattern)

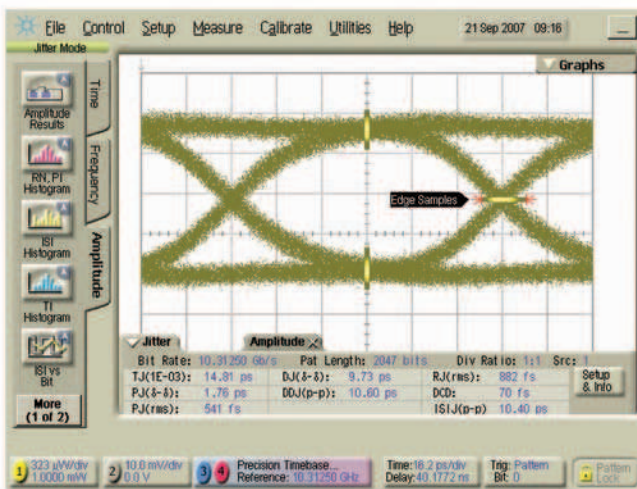

Figure 11. Jitter measurement of the optical signal using the N4917A-E01 without any jitter added (PRBS $2^{11}-1$ pattern)

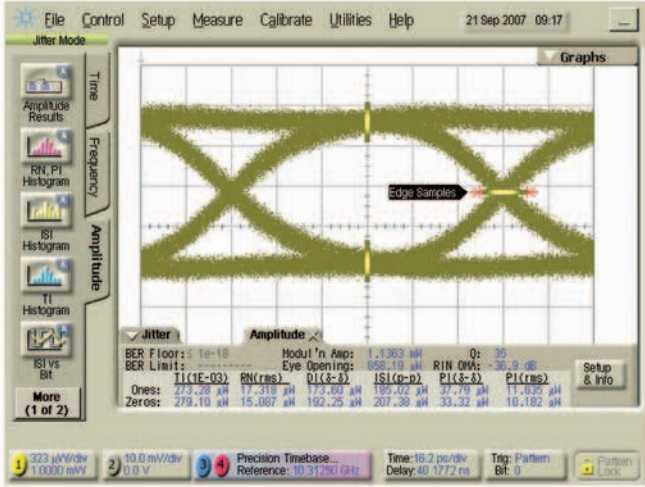

Figure 12. Amplitude measurement of the optical signal using the N4917A-E01 without any jitter added (PRBS 2¹¹-1 pattern)

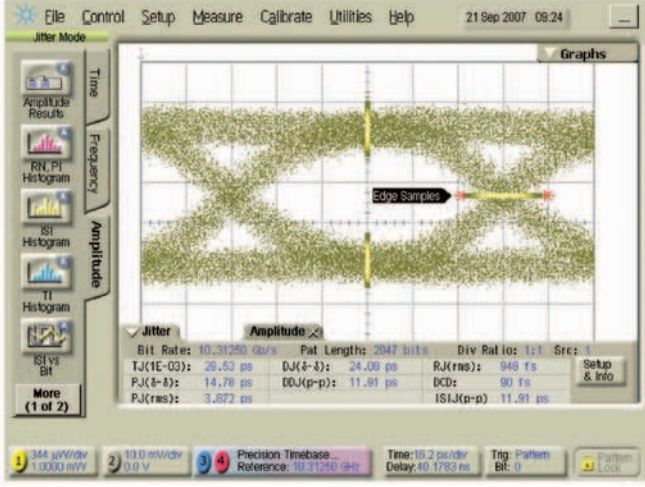

Figure 13. Jitter measurement of the optical signal using the N4917A-E01 with 50 mUI periodic jitter and sinusoidal jitter added for a VECP of 2.2 (PRBS 2¹¹-1 pattern)

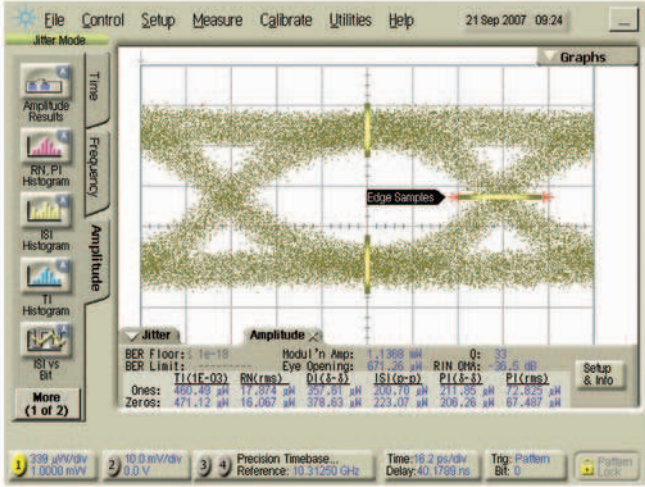

Figure 14. Amplitude measurement of the optical signal using the N4917A-E01 with 50 mUI periodic jitter and sinusoidal jitter added for a VECP of 2.2 (PRBS 2¹¹-1 pattern)

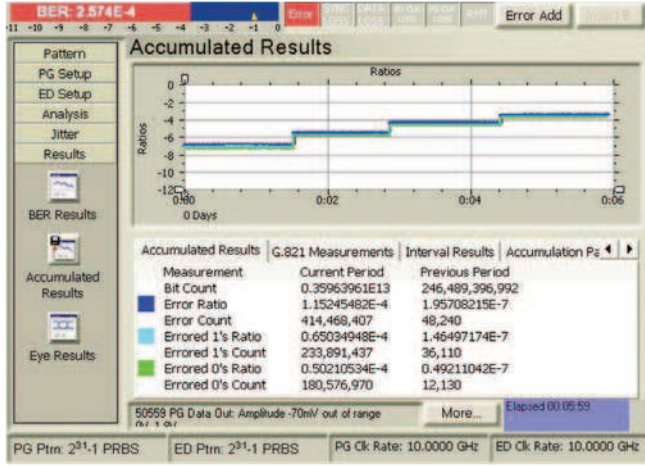

Figure 15. Short term stability: the OMA is varied that an actual DUT delivers finite BER, the measurement runs for 6 minutes and the BER is continuously recorded (x-axis is time, y-axis is BER)

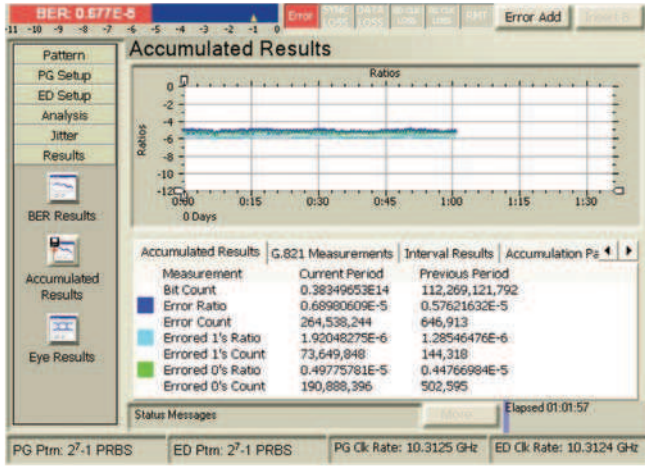

Figure 16. Long term stability: the OMA is set that an actual DUT delivers a BER = .6e-5, the measurement runs for 1 hour and the BER is continuously recorded (x-axis is time, y-axis is BER)

Optimization, Adjustments and DUT Configuration

The setup to run the N4917A software with the necessary accessories is described in Figure 17. The N4917A automation and calibration software provides adjustable parameters for ER, OMA, SI and PJ. At the standard compliance settings it displays the values for A0, VECP and the total jitter (TJ) according to the definition of IEEE802.3ae 2002 with help of an extrapolation from measured point gathered during a calibration process.

The software performs a cabling check, including an optimization for the phase matching of the differential data connection between N4903B data out and N4917A-E01 data in. This optimization is recommended the first time after setup, or whenever the cabling was removed. This cabling check is required for the 10GbE and 10GFC standards, for the 8GFC this check might be skipped by the user.

Beside the base points for the above parameters, it optimizes the operating point of the 81490A reference transmitter and it optimizes the crossing point of the optical signal for a minimum amount of duty cycle distortion (DCD).

The gathered information is stored in a file with reference to date and standard, which can be loaded any time later, multiple files can be generated, per default the latest is in use. Beside the optimization and the adjustments, the software stores in the second step the setup of the DUT.

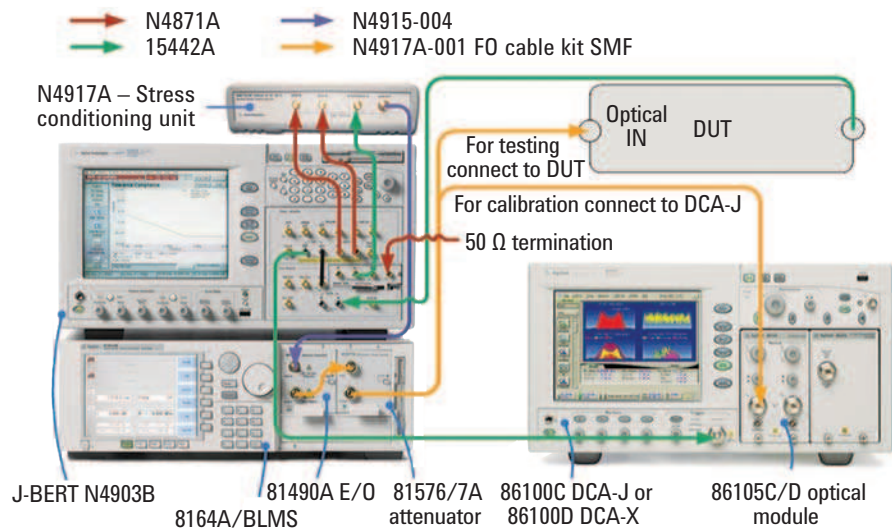

Figure 17. Setup for calibration including the recommended accessories for the 10GbE and 10GFC standards

Software/PC Requirements

N4917A software runs on an external PC/MS Windows XP or Windows 7 (32 bit only)

Requirements:

VGA (640 x 480), MS Windows XP operating system with SP2, Microsoft.NET Framework 2.0

Agilent IO Libraries Suite rev. 15.5 or later, Agilent N490X IVI - COM Driver 1.2.7

Interfaces: USB

Instruments firmware requirement:

N4903B rev 7.2 or higher

81600C rev. FW A10.01 or higher

86100D FW A 10.70

8164B rev. 5.25 or higher

Order Instructions

N4917A-001 Single mode fiber kit containing:

2x patch cords FC/PC - FC/PC single mode

1x patch cord LC/PC - FC/PC single mode

4x 81000FI connector interface FC/PC/SPC

1x 81000LI connector interface LC (DUT)

N4917A-003 Multimode fiber kit containing:

1x patch cord FC/PC - FC/PC multimode 50 μ m

1x patch cord FC/APC - FC/PC multimode 50 μ m

1x patch cord LC/PC - FC/PC multimode 50 μ m

1x 81000FI connector interface FC/PC/SPC

1x 81000NI connector interface FC/APC

1x 81000LI connector interface LC (DUT)

N4917A-E01 Receiver stress conditioning unit and calibration and automation software CD ROM

10 Gb Ethernet - LR, - ER and 10 GFC

N4917A-E03 Receiver stress conditioning unit and software CD ROM

10 Gb Ethernet -SR and 8GFC (only for software)

Recommended accessories (not included in N4917A-E01/-E03):

1x 82357B USB/GPIB interface or 1x E5810A LAN/GPIB Gateway

3x 10833A/B GPIB cable, 1/2m

1x N4871A matched cable pair

1x 15442A four SMA cables

1x N4915A-004 2.4 mm cable

1x 8710-1765 torque wrench

1x 15442A four SMA cables (only for 8GFC; in addition for connecting

N4903B-J20)

Order Instructions *continued*

Table 3. Recommended and supported instruments

Recommended instrument models and options	1310/1550 nm (10GBase-ER,-LR, 10GFC)	850 nm (10GBase-SR, 8GFC)
BERT	N4903B, -C13, -J10, -J12, -J20	
Stress conditioning unit with calibration and automation software	N4917A-E01	N4917A-E03 (SW 1.3 or higher for support of 8GFC)
E/O	81490A-135	81490A-E03
LMS mainframe	8164B	
Attenuator	81576A	N7766A-050
Oscilloscope mainframe	86100D-ETR, -200, -300	
Oscilloscope module	86105C-100, -200, -300	

Other usable instrument models and options	1310/1550 nm (10GBase-ER,-LR, 10GFC)	850 nm (10GBase-SR, 8GFC)
BERT	N4903A/B-CTR, -A01, -J11, -D14, -002, -A02	
LMS mainframe	8163A, 8164A, 8163B, 8166A, 8166B	
O/E	81495A-085	
Attenuator	81577A (the fibers with angled connectors are not provided with the N4917A-E01)	
	N7751A, N7752A, N7761A, N7762A, N7764A	N7768A
Oscilloscope mainframe	86100C-001,-200, -300, -201/-202	
Oscilloscope modules	86105B-101/ -102/ -103/ -111/ -112/ -113	
	86107A	
	86105D	

Not supported instrument models and options

N4903B -C07 -G07 -G13

Productivity assistance:

Remote or on-site (R1380-N49xx)

Productivity assistance (PS-S20 and PS-S20-02)

Warranty extension:

1 year Return-to-Agilent warranty extended to 3 years (R-51B-003-C)

Related Agilent Literature

<i>Improving the Accuracy of Optical Transceiver Extinction Ratio Measurements</i>	5989-2602EN
<i>Agilent J-BERT N4903B High-Performance Serial BERT with Complete Jitter Tolerance Testing Data Sheet</i>	5990-3217EN
<i>BERT Family Brochure</i>	5988-9514EN
<i>Agilent 86100C Wide-Bandwidth Oscilloscope Mainframe and Modules Data Sheet</i>	5989-0278EN
<i>Agilent 86100D DCA-X Wide-Bandwidth Oscilloscope Data Sheet</i>	5990-5824EN
<i>Agilent 8163B Lightwave Multimeter, 8164B Lightwave Measurement System, 8166B Lightwave Multichannel System Data Sheet</i>	5988-3924EN
<i>Agilent 86105C High Sensitivity, Broad Wavelength Plug-In Module Data Sheet</i>	5989-1604EN
<i>Agilent 81490A Reference Transmitter 1310 & 1550 nm Data Sheet</i>	5989-7326EN
<i>Agilent 81495A Reference Receiver Data Sheet</i>	5989-7526EN
<i>Agilent N77-Series Attenuators Data Sheet</i>	5990-4394EN



Agilent Advantage Services

Agilent Advantage Services is committed to your success throughout your equipment's lifetime. To keep you competitive, we continually invest in tools and processes that speed up calibration and repair and reduce your cost of ownership. You can also use Infoline Web Services to manage equipment and services more effectively. By sharing our measurement and service expertise, we help you create the products that change our world.

www.agilent.com/find/advantageservices



www.agilent.com/quality

For more information on Agilent Technologies' products, applications or services, please contact your local Agilent office. The complete list is available at:
www.agilent.com/find/contactus

Windows and MS Windows are U.S. registered trademarks of Microsoft Corporation.

 **Agilent Email Updates**

www.agilent.com/find/emailupdates
 Get the latest information on the products and applications you select.



www.lxistandard.org
 LAN eXtensions for Instruments puts the power of Ethernet and the Web inside your test systems. Agilent is a founding member of the LXI consortium.

Agilent Channel Partners

www.agilent.com/find/channelpartners
 Get the best of both worlds: Agilent's measurement expertise and product breadth, combined with channel partner convenience.

<u>Americas</u>		<u>Europe & Middle East</u>	
Canada	(877) 894 4414	Belgium	32 (0) 2 404 93 40
Brazil	(11) 4197 3600	Denmark	45 45 80 12 15
Mexico	01800 5064 800	Finland	358 (0) 10 855 2100
United States	(800) 829 4444	France	0825 010 700*
			*0.125 €/minute
<u>Asia Pacific</u>		Germany	49 (0) 7031 464 6333
Australia	1 800 629 485	Ireland	1890 924 204
China	800 810 0189	Israel	972-3-9288-504/544
Hong Kong	800 938 693	Italy	39 02 92 60 8484
India	1 800 112 929	Netherlands	31 (0) 20 547 2111
Japan	0120 (421) 345	Spain	34 (91) 631 3300
Korea	080 769 0800	Sweden	0200-88 22 55
Malaysia	1 800 888 848	United Kingdom	44 (0) 118 927 6201
Singapore	1 800 375 8100		
Taiwan	0800 047 866		
Other AP Countries	(65) 375 8100		

For other unlisted countries:
www.agilent.com/find/contactus
 Revised: January 6, 2012

Product specifications and descriptions in this document subject to change without notice.

© Agilent Technologies, Inc. 2010, 2012
 Printed in USA, May 23, 2012
 5989-6315EN