



# Agilent U4421A MIPI™ D-PHY Protocol Exerciser/Analyzer

Data Sheet



*Bring your CSI-2 and DSI-1 designs  
to market faster — with complete confidence*

Anticipate — Accelerate — Achieve



**Agilent Technologies**

# The MIPI D-PHY Analyzer

Two instruments in one —  
(available with Option 601 or 603)

Link multiple windows together or track correlated events with markers.

Isolate any packet's header.

See data as a packet payload or as individual lanes.

Any number of filters and views can be applied. Organize them easily in the overview GUI.

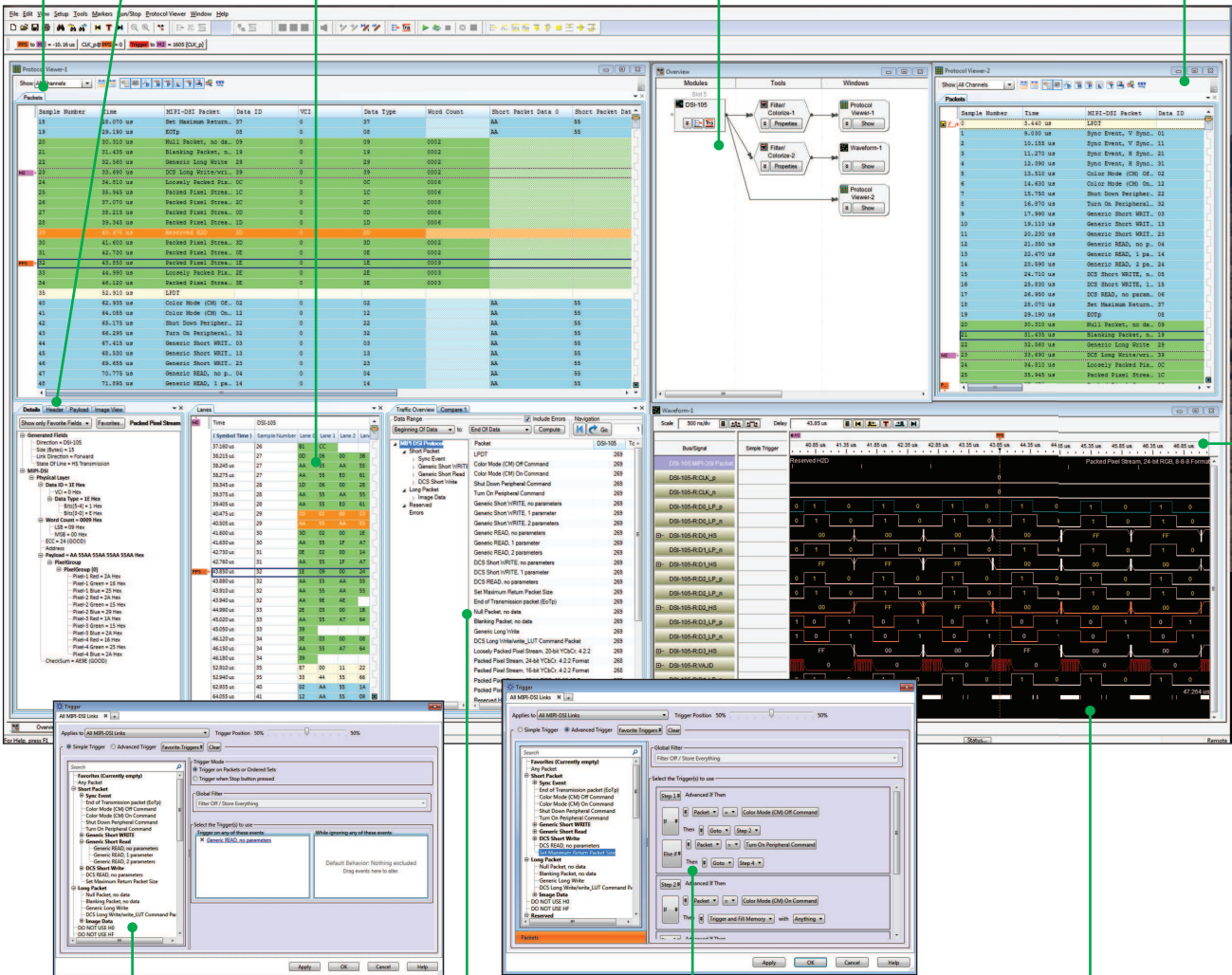

Quickly customize simple drag-and-drop trigger macros.

Get the "big picture" with the Overview tab.

Use advanced if-then-else triggers to branch in any direction to up to eight different conditions. Add counters, timers, and flags for even more control.

Raw Mode lets you see the "why" behind your protocol.

The U4421A MIPI D-PHY Analyzer option for CSI-2 and DSI gives you deep insight into your mobile computing designs.

**Time correlate multiple busses and views.** Up to five modules (D-PHY, PCI, DDR, high-speed logic, and HDMI) can be correlated in one mainframe, and multiple frames can be connected. Any number of filters and views can be applied. Organize them easily in the overview GUI. Link multiple windows together or track correlated events with markers.

**Look deeply into packets with “peel off” tabs.** Isolate any packet’s header, or data as a packet payload or individual lanes.

**Raw Mode lets you see the “why” behind your protocol.** Raw state data that is acquired by the analyzer can be displayed as a time-correlated waveform view.

**Get the “big picture” with the Overview tab.** Get a count of the various types of traffic in any period

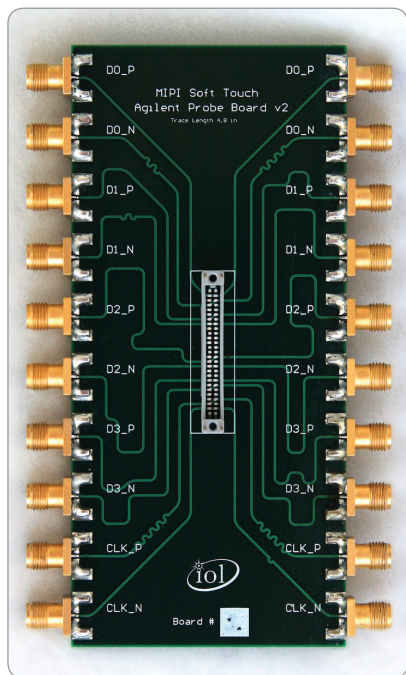

of time, including errors; then step through each occurrence with embedded navigation tools.

**Isolate events with protocol-aware triggers.** Simple drag-and-drop trigger macros can be quickly customized. Or use advanced if-then-else triggers to branch in any direction to up to eight different conditions. Trigger on packet types, errors or into payload data.

**Probe any system with three flexible probing options (below).** The E5381A differential flying leads let you connect to vias, headers, and traces. The E5404A Soft Touch Pro probe gives you a rugged in-board connection to a small footprint. In addition, UNH-IOL® has created an SMA to Soft Touch break-out board that connects directly to their Reference Termination Board, or be used as a generic mid-bus adapter.

### Key features:

- Protocol aware for DSI and CSI-2 traffic in all views, triggers, and filters
- Up to 1.5 Gb data rate
- Up to 16 GB Trace Depth
- Up to 4 data lanes + CLK
- 5-ns resolution raw mode data
- N-way trigger branching
- Integrated image extraction software

### Target users:

#### Designers and Validators of

- Mobile devices
- Mobile embedded systems
- MIPI silicon/IP
- Cameras

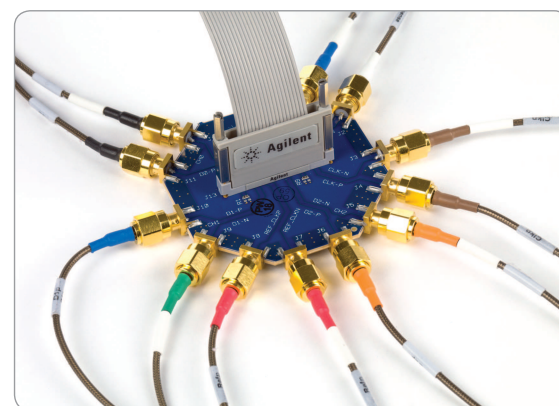
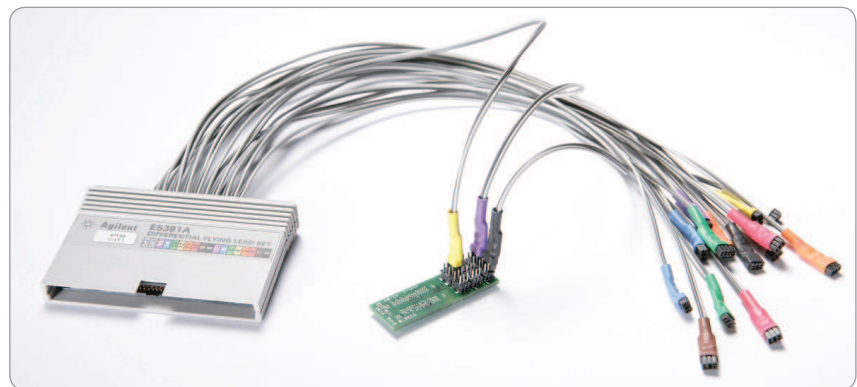

# MIPI D-PHY Exerciser

## Two instruments in one

(available with option 602 or 603)

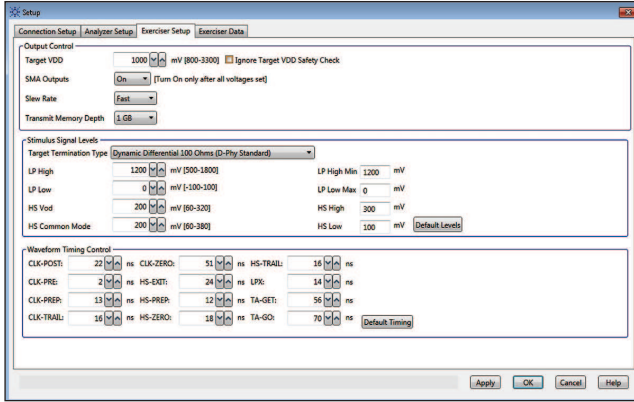

End-to-end data path analysis: Quickly create exerciser traffic ...

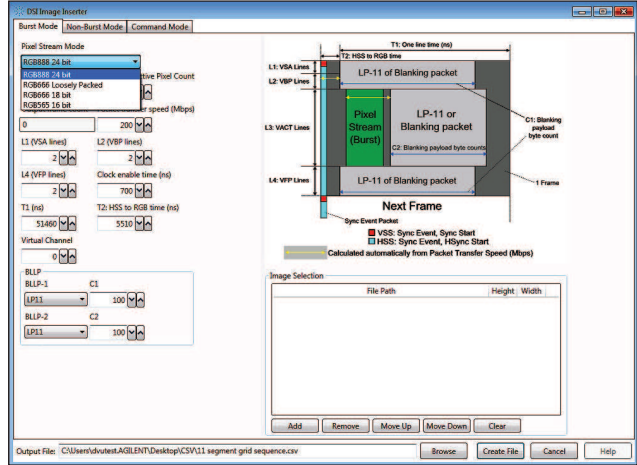

... based on images or commands ...

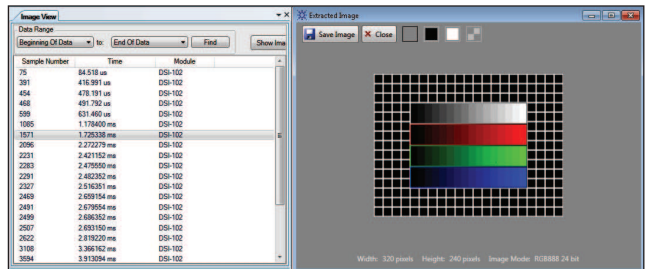

... analyze and extract the transmitted images by physically probing or using the analyzer's internal loopback.

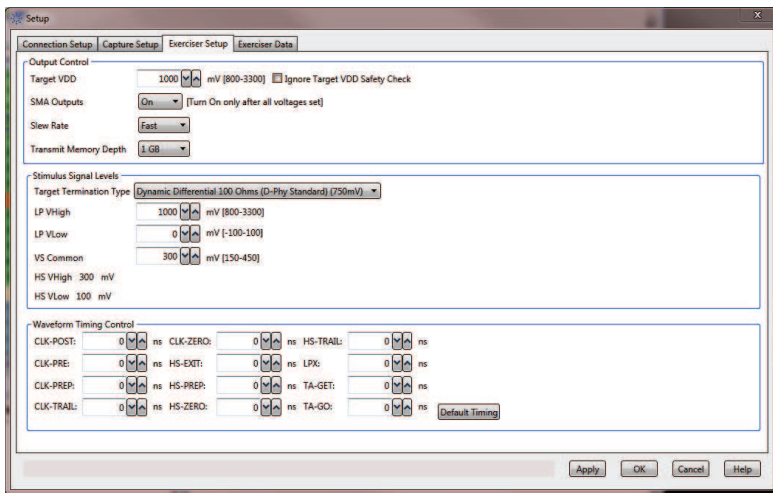

Adjust timing parameters including data rate, output voltages, skew rate, signal timing ...

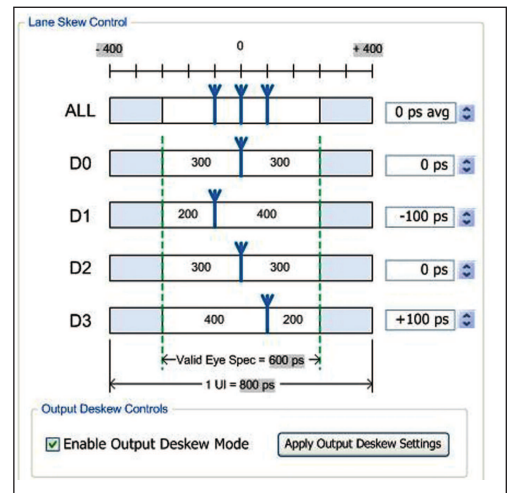

... and lane skew

The U4421A MIPI D-PHY Exerciser option for CSI-2 and DSI provides the record depth necessary to stimulate designs with high-definition images and video. It also lets you simulate traffic from a wide variety of devices buses of varying signal performance.

Deep memory. With 1GB of standard memory, and with options for 4GB and 16 GB, you can generate long sequences of high definition images and videos.

Internal loopback, available with the U4421A analyzer options 601 and 603, lets you verify the exerciser's output. This gives you additional confidence in the data that you are sending to your target.

Change both HP and LP signal levels to understand how your system reacts to diminished signal voltages. A system that can tolerate lower signal swings will usually have a longer battery life.

Change signal data rate, slew rate, and lane timing to get insight into how your systems and peripherals react to a wide variety of CSI and DSI signals. Bring the "plug-fest" experience to your bench.

Generate traffic quickly with your own CSV files, the integrated packet inserter or the optional image inserter software. Recall your favorite patterns with user-defined "hot" (shortcut) keys.

### Key features:

- Generate user-defined D-PHY traffic
- Up to 1.5 Gb data rate
- Up to 16 GB trace depth
- Change speed, slew rate, voltage levels and lane skew
- Flexible pattern creation
  - = GUI
  - = Packet inserter
  - = Image inserter

### Target users:

#### Designers and Validators of

- Mobile devices
- Mobile embedded systems
- MIPI silicon/IP
- Displays



Each module can simultaneously be an exerciser and an analyzer. Combine multiple modules in a 2 (M9502A) or 5 (M9505A) slot AXIe mainframe to analyze and simulate cross-system behavior.

## Agilent U4421A – Analyzer Option (601) Performance Characteristics

Electrical	
HSV minimum differential	100 mV
LPV threshold range	0 to 1.5 V
Lane width	Up to 4 with option 004. Analyze 1-, 2-, 3-, or 4-lane systems.
Performance	
Maximum bit rate (high-speed mode)	1.5 Gbps
Minimum bit rate (high-speed mode)	80 Mbps
Maximum bit rate (low-power mode)	10 Mbps
Minimum bit rate (low-power mode)	N/A
Raw Mode LP sample resolution	5ns, typical for LP traffic; 1 ÷ bit rate for HS traffic
Maximum data rate of probes	
E5381A	1.5 Gbps with 82Ω coaxial resistor adapter, 1.0 Gbs with damped wire and 3-pin header adapters.
E5405A	1.5 Gbps
Memory	
	User allocated (shared among Exerciser, Analyzer and Raw Mode)
Standard	1 Gb
Option M04 (recommended for images)	4 GB
Option M16 (recommended for video)	16 GB
Protocol	
Protocol version support	
Display	Display Serial Interface (DSI) v1.1 Display Serial Interface (DSI) v1.02.00 Display Serial Interface Version 1.01.00 Display Command Set (DCS) v1.1 Display Command Set (DCS) v1.02.00 Display Command Set v1.01.00 Stereoscopic Display Formats (SDF) v1.0
Camera (CSI-2)	Camera Serial Interface 2 v1.01.00 Camera Serial Interface 2 v1.00 (CSI-2)
Protocol viewer	Hierarchical packet-level display
Protocol views	Packets, header, lanes, payload, and traffic overview
Protocol decoder	
Simultaneous HS and LP data support	Yes
Short and long packet decode	Yes
CSI-2 and DSI-1 decode	Yes, user selectable
Waveform view (Raw Mode)	Packets and lanes
Error display	
SOT error display	Yes
EOT error display	Yes
Escape error display	Yes
Sequence error display	Yes
Turnaround error display	Yes
ECC, CRC error display	Yes
Contention detection	No
Track changes in speed (HS/LP) mode	Yes – default packet color scheme
Correlation markers	>1,000 user-defined
Marker measurements	Yes, user-defined time and count measurements.
Window correlation lock	Yes, user-defined

Triggering capabilities	
Trigger on protocol commands	Yes, with >130 macros
Simple trigger	Drag and drop
Advanced trigger	
Sequence levels	Up to 8
Logical branching	N-way
Trigger on protocol patterns	Yes, on both DSI and CSI long and short packet headers
Protocol pattern customization	Yes, with bit-level editing
Payload pattern matcher	First 4 bytes
Event counter	Yes
Time counter	Yes, 100ns accuracy
Real-time error detection	5 ns resolution $\pm 5$ ns of accuracy
SOT error trigger	Yes, on a per lane basis
EOT error trigger	Yes, on a per lane basis
Escape error trigger	Yes, on a per lane basis
Sequence error trigger	Yes, on a per lane basis
Turnaround error trigger	Yes, on a per lane basis
ECC	Yes
CRC	Yes
Display	
Low power state of data transmission	All escape mode actions, except ultra-low power
Stopped	No
Image Extractor (Option 001)	
CSI	YUV422 - 8 bit YUV420 Legacy – 8 bit RGB888 - 24 bit RGB565 - 16 bit
DSI	RGB888 – 24 bit RGB666 Loosely Packed RGB666 Packed – 18 bit RGB565 – 16 bit

## Agilent U4421A – Exerciser Option (602) Performance Characteristics

Electrical	LSR features
Lane width	Up to 4 with option 004. Exercise 1-, 2-, 3-, or 4-lane systems.
Low-power voltage high adjustment	500 mV to 1.5 V
Low-power voltage low adjustment	±100 mV
High-speed output differential voltage	60 mV to 320 mV
High-speed common mode voltage	60 mV to 380 mV
Output driving impedance	High-speed: 50 Ω; Low-power: 82.4 Ω
Bus termination modes	Open, dynamic, static 100 Ω differential
Waveform timing control	Yes, automatic or manual settings
CLK-POST timing control	Yes, automatic or manual settings
CLK-PRE timing control	Yes, automatic or manual settings
CLK-PREPARE timing control	Yes, automatic or manual settings
CLK-TRAIL timing control	Yes, automatic or manual settings
CLK-ZERO timing control	Yes, automatic or manual settings
HS-EXIT timing control	Yes, automatic or manual settings
HS-PREPARE	Yes, automatic or manual settings
HS-ZERO	Yes, automatic or manual settings
HS-TRAIL	Yes, automatic or manual settings
LPX	Yes, automatic or manual settings
TA_Get	Yes, automatic or manual settings
TA_GO	Yes, automatic or manual settings
CLK lane and data lane skew adjust	5 ps, resolution typical; ± 0.5 UI @ 1 Gb and above
Reference clock input	Required, Clock input = 1/10 bit rate to 700 Mbs, 1/20 above 700 Mb
Performance	
Maximum bit rate (high-speed mode)	1.5 Gbps
Minimum bit rate (high-speed mode)	80 Mbps
Maximum bit rate (low-power mode)	10 Mbps
Minimum bit rate (low-power mode)	800 Kbps
Memory	User allocated (shared among Exerciser, Analyzer and Raw Mode)
Standard	1 GB
Option M04 (recommended for images)	4 GB
Option M16 (recommended for video)	16 GB

## Packet Insertion

HSDT request error generation	Yes, with timing control to violate specs
SOT synch error generation	No
Endof HSDT error generation	Yes, with timing control to violate specs
LPD transmission error generation	Yes, with waveform timing control and direct control of data transmitted on the link
Protocol errors	Yes
Turnaround error generation	No (does not operate in slave mode)
ECC, CRC error generation	Manual

## Image Inserter (Option 003)

### CSI

Maximum bit rate (high-speed mode)	Legacy YUV 420 – 8 bit YUV 422 – 8 bit RGB 888 – 24 bit RGB 565 – 16 bit RAW data (This is not RAW8 / 10 etc. The s/w simply reads data from a bin file and makes CSI packets out of them)
------------------------------------	--

### DSI

Burst Mode	RGB888 - 24 bit RGB666 Loosely packed RGB666 - 18 bit RGB565 - 16 bit
Non Burst Mode	RGB888 - 24 bit RGB666 Loosely packed RGB666 - 18 bit RGB565 - 16 bit
Command Mode	RGB888 - 24 bit RGB666 - 18 bit RGB565 - 16 bit RGB444 - 12 bit RGB111 - 3 bit

## Module Configuration

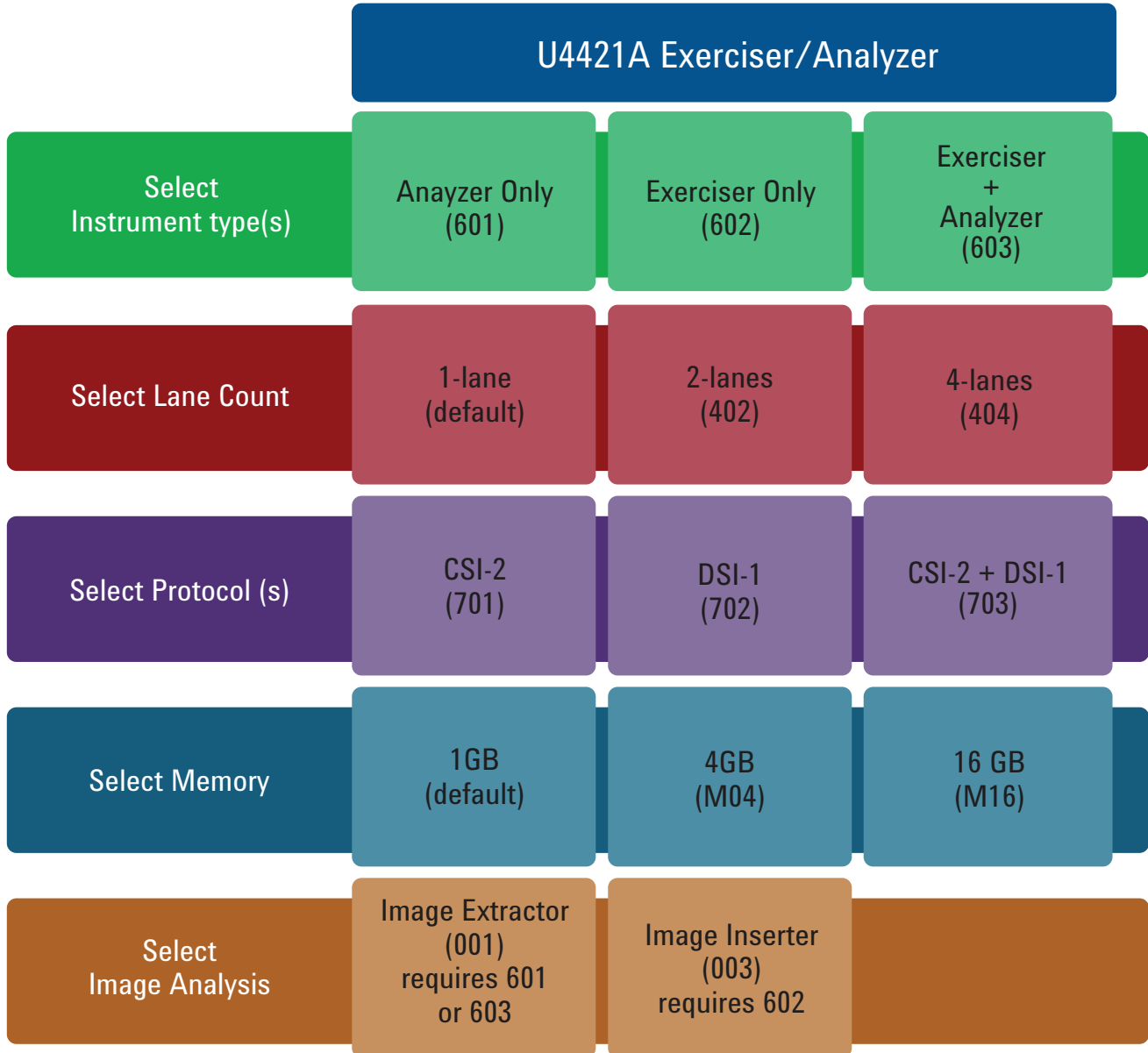

## Chassis and Probing Configuration

### Chassis Options

M9502A      2-slots  
M9505A      5-slots

### PC Control Options

M9536A      Embedded PC module (no cables or adapters needed)  
M9045A      ExpressCard Adapter  
M9047A      PCIe Desktop Adapter  
Y1200B      PCIe Cable (x4 to x8)

### Analyzer Probes (with options 601 or 603)

U4201A      REQUIRED (Logic Cable)

*Pick one or more of the following*

E5381A      Flying Lead Adapter  
E5405A      Soft Touch Adapter  
SMA breakout to Soft Touch Adapter (available from UNH-IOL)

### Exerciser Probe (with options 602 or 603)

U4422A      SMA cable, MIPI D-PHY, 13 leads/1.5 Gbps



### Agilent Email Updates

[www.agilent.com/find/emailupdates](http://www.agilent.com/find/emailupdates)

Get the latest information on the products and applications you select.



[www.axistandard.org](http://www.axistandard.org)

AdvancedTCA® Extensions for Instrumentation and Test (AXIe) is an open standard that extends the AdvancedTCA for general purpose and semiconductor test. Agilent is a founding member of the AXIe consortium.



[www.lxistandard.org](http://www.lxistandard.org)

LAN eXtensions for Instruments puts the power of Ethernet and the Web inside your test systems. Agilent is a founding member of the LXI consortium.



[www.pxisa.org](http://www.pxisa.org)

PCI eXtensions for Instrumentation (PXI) modular instrumentation delivers a rugged, PC-based high-performance measurement and automation system.

### Agilent Channel Partners

[www.agilent.com/find/channelpartners](http://www.agilent.com/find/channelpartners)

Get the best of both worlds: Agilent's measurement expertise and product breadth, combined with channel partner convenience.



Agilent Advantage Services is committed to your success throughout your equipment's lifetime. To keep you competitive, we continually invest in tools and processes that speed up calibration and repair and reduce your cost of ownership. You can also use Infoline Web Services to manage equipment and services more effectively. By sharing our measurement and service expertise, we help you create the products that change our world.

[www.agilent.com/find/advantageservices](http://www.agilent.com/find/advantageservices)



[www.agilent.com](http://www.agilent.com)

For more information on Agilent Technologies' products, applications or services, please contact your local Agilent office. The complete list is available at:

[www.agilent.com/find/contactus](http://www.agilent.com/find/contactus)

#### Americas

Canada	(877) 894 4414
Brazil	(11) 4197 3600
Mexico	01800 5064 800
United States	(800) 829 4444

#### Asia Pacific

Australia	1 800 629 485
China	800 810 0189
Hong Kong	800 938 693
India	1 800 112 929
Japan	0120 (421) 345
Korea	080 769 0800
Malaysia	1 800 888 848
Singapore	1 800 375 8100
Taiwan	0800 047 866
Other AP Countries	(65) 375 8100

#### Europe & Middle East

Belgium	32 (0) 2 404 93 40
Denmark	45 45 80 12 15
Finland	358 (0) 10 855 2100
France	0825 010 700*
	*0.125 €/minute
Germany	49 (0) 7031 464 6333
Ireland	1890 924 204
Israel	972-3-9288-504/544
Italy	39 02 92 60 8484
Netherlands	31 (0) 20 547 2111
Spain	34 (91) 631 3300
Sweden	0200-88 22 55
United Kingdom	44 (0) 118 927 6201

For other unlisted countries:

[www.agilent.com/find/contactus](http://www.agilent.com/find/contactus)

Revised: January 6, 2012

Product specifications and descriptions in this document subject to change without notice.

© Agilent Technologies, Inc. 2012  
Published in USA, June 8, 2012  
5991-0488EN



Agilent Technologies