

Agilent 55280B Linear Measurement Kit

Data Sheet

Basic Equipment

Agilent 5530 Laser Calibration System
Agilent 55280B Linear Optics Kit

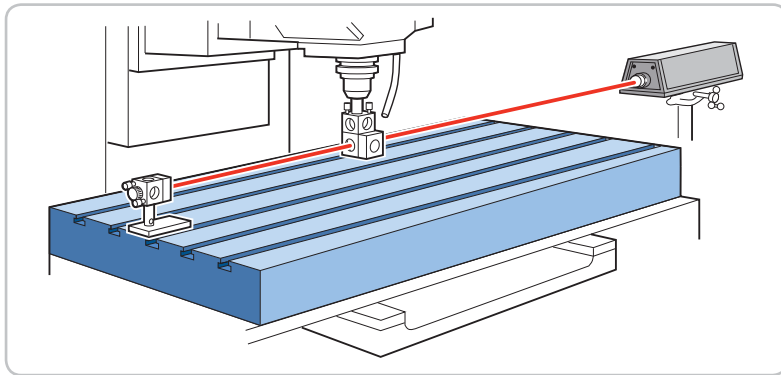

Optical setup for linear measurements

Linear measurements are made at multiple points along a machine's travel path to measure linear displacement and velocity.

The purpose of the measurement is to document capability and, when possible, improve positioning accuracy along an axis for any machine that requires positioning accuracy and velocity control through a compensation table.

Additional capabilities include long-term thermal drift test which can be performed over hours or days, showing possible effects of temperature on geometry.

The following specifications assume Agilent 5530 Laser Calibration System is in used, and the temperature of all optical components is stabilized in the range 15 °C to 25 °C.

Measurement Range

Up to 40 m (130 ft) with linear optics

Up to 80 m (260 ft) with long range option

Measurement Accuracy

Temperature range	E1738A air sensor	In vacuum †
0 – 40 °C (32 ° – 104 °F)	±0.4 ppm	±0.1 (±0.02) ppm

† Vacuum accuracy is ±0.02 ppm if the 5519A/B laser head is calibrated to MIL-STD 45662A.

Measurement Resolution

Optics	Resolution
Linear optics (10766A)	1 nm (0.04 µin)
Plane mirror optics (10706A/B)*	0.5 nm (0.02 µin)
High resolution plane mirror optics (10716A) **	0.25 nm (0.01 µin)

* Requires the 10724A Plane Mirror Reflector. Since alignment of these optics is much more sensitive than for linear optics, linear optics are recommended for general use.

‡ Aperture distance of 10716A is 12.7 mm, whereas 5519A is 11 mm.



Components included in the 55280B Linear Measurement Kit

Description	Quantity
10766A Linear interferometer	1
10767A Linear retroreflector	2
10784A Base	2
10785A Height adjuster	3
Post (~ 100 mm)	3

Related Literature

Publication title	Publication number
Agilent 5530 Laser Calibration System Brochure	5989-9354EN
Agilent 5530 Laser Calibration System Data Sheet	5989-9712EN
Agilent 5530 Laser Calibration System Flyer	5989-9707EN



Agilent Email Updates

www.agilent.com/find/emailupdates

Get the latest information on the products and applications you select.

www.agilent.com

www.agilent.com/find/5530

For more information on Agilent Technologies' products, applications or services, please contact your local Agilent office. The complete list is available at:

www.agilent.com/find/contactus

Americas

Canada	(877) 894 4414
Brazil	(11) 4197 3600
Mexico	01800 5064 800
United States	(800) 829 4444

Asia Pacific

Australia	1 800 629 485
China	800 810 0189
Hong Kong	800 938 693
India	1 800 112 929
Japan	0120 (421) 345
Korea	080 769 0800
Malaysia	1 800 888 848
Singapore	1 800 375 8100
Taiwan	0800 047 866
Other AP Countries	(65) 375 8100

Europe & Middle East

Belgium	32 (0) 2 404 93 40
Denmark	45 45 80 12 15
Finland	358 (0) 10 855 2100
France	0825 010 700*
	*0.125 €/minute
Germany	49 (0) 7031 464 6333
Ireland	1890 924 204
Israel	972-3-9288-504/544
Italy	39 02 92 60 8484
Netherlands	31 (0) 20 547 2111
Spain	34 (91) 631 3300
Sweden	0200-88 22 55
United Kingdom	44 (0) 118 927 6201

For other unlisted countries:

www.agilent.com/find/contactus

Revised: January 6, 2012

Product specifications and descriptions in this document subject to change without notice.

© Agilent Technologies, Inc. 2012
Published in USA, July 4, 2012
5990-9311EN



Agilent Technologies