

Agilent N7786B Polarization Synthesizer

Data Sheet



Figure 1. N7786B polarization synthesizer

Introduction

The Agilent N7786B contains a high-speed lithium-niobate based polarization controller and a polarization analyzer plus a microcontroller-based driving circuitry.

This unit can operate in various modes:

As a polarization stabilizer, it provides a stable output state of polarization (SOP) even with fluctuations and drifts of the input SOP. The stabilized output signal is guided in a standard single-mode fiber (SMF). The output SOP can be defined in the following ways:

- **Set-and-forget:** When the front button is pushed, the current SOP is stored and maintained, even if polarization changes occur on the instrument input.
- **Defined stokes:** The target output SOP can be defined by the user using the Stokes parameters.
- As a **synchronous scrambler**, the device switches the SOP of the output signal in a random (pseudo) way with a cycling speed of up to 100 KSOPs/s.

SOP switching occurs within a few microseconds. An electrical trigger input can be used to synchronize the scrambler with external events.

As an **SOP switch**, the N7786B cycles through a sequence of SOPs with a speed of more than 40 KHz, which corresponds to a cycle time of less than 25 microseconds. The sequence of SOPs can easily be defined by the user using Stokes coefficients.

As a traditional **scrambler**, the N7786B varies the output SOP in a random way.

Full coverage of the Poincaré Sphere is achieved within a few ms.

As a **polarization analyzer**, the instrument provides truly high-speed capabilities: More than 500K samples can be taken with a sample rate of up to 1 Megasample per second.

As **fast-switching polarization controller** for single-sweep wavelength dependent PDL measurements in combination with the N7700A PDL software and an Agilent tunable laser and power meter. See the N7700A literature for details.

All above-mentioned applications of the N7786B are supported by Agilent PC software that comes with this instrument.

Various instrument drivers and connectivity to external applications are provided through a DLL interface. Examples are included.



Key benefits

- Comprehensive polarization stabilization/control
- Fast switching capabilities
- Enables single-sweep spectral PDL measurements with N7700A PDL software engine.
- Reset-free/ endless operation
- Covers entire range from 1.3 μm window up to the L-band
- Standalone operation
- Robust, no moving parts

Applications

- Swept-wavelength PDL measurements with tunable laser and N7700A software
- **Transmission system test:** Polarization sensitivity analysis on link/transmission quality
- **Recirculating loop experiments:** Loop-synchronous polarization scrambling
- **Interferometry:** Polarization stabilization to maximize contrast ratio
- Polarization analysis

Agilent N7786B Instrument Setup and Application Examples

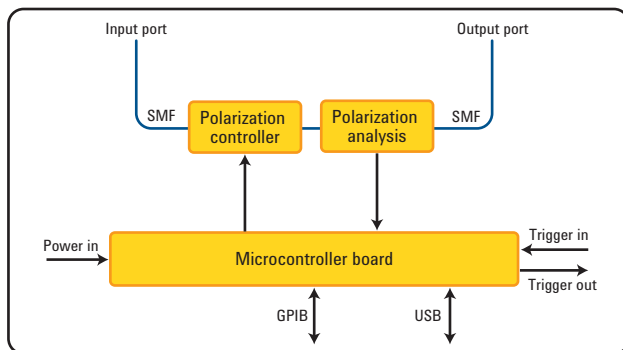

Figure 2. Instrument setup

The instrument setup is shown in Figure 2. A DSP-based electronics controls the polarization analyzer as well as the polarization controller. The SOP can be stabilized by means of a closed-loop operation of the DSP.

Application examples

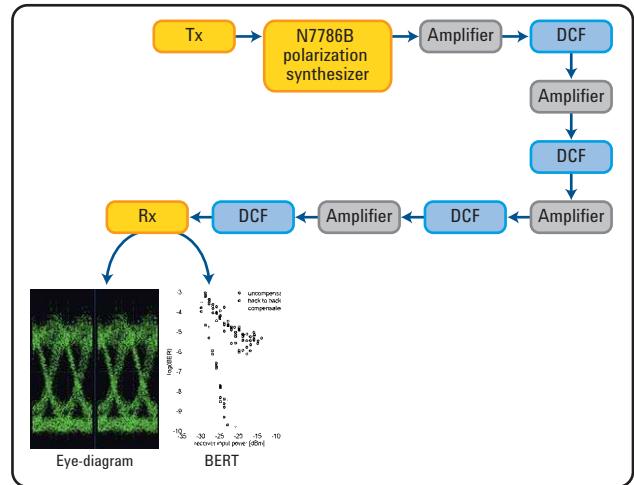

Figure 3. Transmission experiments

The transmission quality of links is known to depend on the state of polarization (SOP) of the launching signal. The N7786B is well suited to launch the modulated signal with predefined SOPs into the link. This allows probing for a range of SOPs on the Poincaré sphere to get information about particular polarization issues of a link.

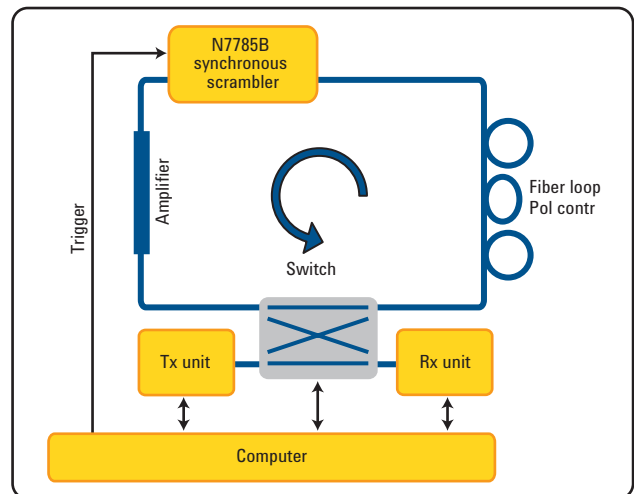

Figure 4. Recirculating loop

The results obtained in re-circulating loop experiments depend heavily on the PMD and PDL properties of the loop. Loop synchronous polarization scrambling schemes have proven to be necessary for generating results comparable to deployed systems. The N7786B is ideally suited to provide the synchronous scrambling capability in such experiments.

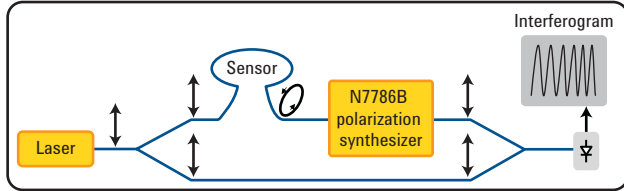

Figure 5. Interferometry/coherent detection

Fiber-optic-based interferometers or coherent receiver schemes need polarization stabilization in order to avoid fading problems of the interference signal. These fading effects are caused by orthogonally polarized fractions of the light. The N7786B allows elimination of such effects by alignment of the signal polarization.

Configuration for swept-wavelength IL and PDL measurements

The N7786B can be combined with the N7700A IL/PDL software package to measure polarization dependent loss and insertion loss spectra on one or multiple channels. The fast switching enables a unique single-sweep Mueller Matrix method that reduces measurement time and is very robust against environmental disturbance like fiber movement and temperature drift, while maintaining high IL dynamic range, wavelength accuracy and freedom from bandwidth-limited distortions. This setup combines a continuously-swept tunable laser with the fast-switching N7786B polarization synthesizer and one or more multiport power meter instruments.

In addition to the measured IL and PDL traces, the Mueller Matrix 1st-row data can be exported and analyzed to provide the polarization resolved IL traces for the device axes (TE/TM).



Figure 6. A very compact configuration for the IL/PDL Engine, to measure 8 channel devices in the C and L band

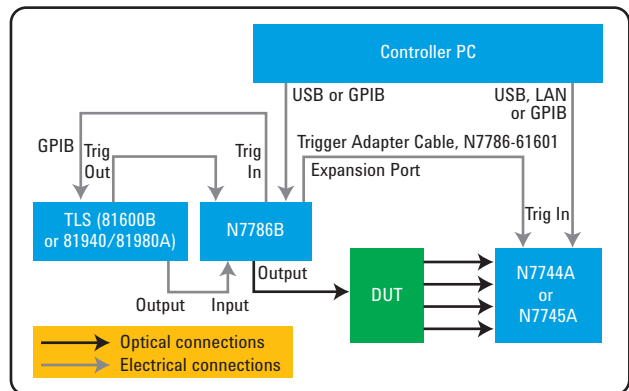

Figure 7. Schematic Setup for Single-Sweep IL and PDL measurements

Specifications ¹ N7786B Polarization Synthesizer

Wavelength		
Specification wavelength range		1270 to 1375 nm
	Opt 400, O/C/L-Band	1460 to 1620 nm
	Opt 500, C/L-Band	1460 to 1620 nm
Operating wavelength range ²	1260 to 1640 nm	
Polarization control and stabilization		
SOP switching time (non-deterministic)	< 10 μ s	
SOP cycling time ⁶	< 25 μ s	
Remaining SOP error after deterministic SOP setting (typical) ⁷	< 3° at input SOP movement rate of 1.2 rad/s	
	< 6.5° at input SOP movement rate of 40 rad/s	
Polarization analysis		
SOP uncertainty (typical) ^{3,4}	1,5°	
DOP uncertainty ³	\pm 2,0%	
DOP uncertainty after user ^{3,5} calibration (typical)	\pm 0,5%	
Optical power measurement		
Relative power uncertainty ³	C/L-Band	\pm 0.14 dB (0.12 dB typical)
	O-Band	\pm 0.16 dB (0.14 dB typical)
Input power range	-38 to +19 dBm	
Optical power		
Insertion loss	< 4.0 dB (< 3.5 dB, typical)	
PDL (typical)	C/L band	< 0.2 dB
	O Band	< 0.5 dB
Maximum safe input power	20 dBm	

1. Ambient temperature change max. \pm 0.5°C since normalization. Specification valid on day of calibration.

2. SOP/DOP measurements are possible outside the specification wavelength range if the user performs a manual calibration.

3. Input power > -20 dBm. The polarization analyzer readout reflects the SOP and power at the instrument output. Thus, effects caused by the internal polarization controller are included.

4. DOP > 95%.

5. User calibration requires a source with a 100% DOP. Valid at a fixed wavelength.

6. The instrument adaptively finds the polarization controller settings to let the SOP cycle through user-defined polarization states (closed loop operation). After having found these settings, the SOP can cycle through the polarization states in open loop operation.

7. This value is defined to be 5 times the standard deviation of the angular SOP error on the Poincaré sphere. Valid if controller is turned on. Power at instrument input > -10 dBm.

Specifications ¹ N7786B Polarization Synthesizer (continued)

Ordering instructions	
Optical connector options	
N7786B-021	Straight contact connectors
N7786B-022	Angled contact connectors
Wavelength options	
N7786B-400	1270 to 1375 nm and 1460 to 1620 nm
N7786B-500	1460 to 1620 nm
Connector interface	
The N7786B should usually be ordered with two 81000xl connector interfaces, depending on desired connector type (not included).	
Accessories	
5063-9240	Rack mount kit for 1 unit with filler panel
5063-9212 + 5061-9694	Rack mount parts for 2 units side-by-side
Warranty	
All systems have 1 year warranty	
R-51B-001-3C	1 year Return-to-Agilent warranty extended to 3 years
R-51B-001-5C	1 year Return-to-Agilent warranty extended to 5 years
Calibration	
R-50C-011-3	Agilent calibration upfront support plan 3 year coverage
R-50C-011-5	Agilent calibration upfront support plan 5 year coverage
General characteristics	
Dimensions (D x W x H)	380 mm x 213 mm x 88 mm (excluding front and back rubber cushions and handle)
Weight	Approx. 4 kg
Recommended recalibration period	24 months
Operating temperature	+5 °C to +40 °C
Operating humidity	0% to 80%, non-condensing
Altitude	The maximum operating altitude is 2000 m.
Pollution protection	Pollution degree 2.
Warm-up time	20 minutes
Interfaces	The instruments can be controlled via USB or GPIB interfaces
Power consumption	Line power: AC 100 to 240 V ± 10%, 50/60 Hz, 60 VA max.

 **Agilent Email Updates**

www.agilent.com/find/emailupdates

Get the latest information on the products and applications you select.

Agilent Channel Partners

www.agilent.com/find/channelpartners

Get the best of both worlds: Agilent's measurement expertise and product breadth, combined with channel partner convenience.



Agilent Advantage Services is committed to your success throughout your equipment's lifetime. To keep you competitive, we continually invest in tools and processes that speed up calibration and repair and reduce your cost of ownership. You can also use Infoline Web Services to manage equipment and services more effectively. By sharing our measurement and service expertise, we help you create the products that change our world.

www.agilent.com/find/advantageservices



For more information on Agilent Technologies' products, applications or services, please contact your local Agilent office. The complete list is available at:

www.agilent.com/find/contactus

Americas

Canada	(877) 894 4414
Brazil	(11) 4197 3600
Mexico	01800 5064 800
United States	(800) 829 4444

Asia Pacific

Australia	1 800 629 485
China	800 810 0189
Hong Kong	800 938 693
India	1 800 112 929
Japan	0120 (421) 345
Korea	080 769 0800
Malaysia	1 800 888 848
Singapore	1 800 375 8100
Taiwan	0800 047 866
Other AP Countries	(65) 375 8100

Europe & Middle East

Belgium	32 (0) 2 404 93 40
Denmark	45 45 80 12 15
Finland	358 (0) 10 855 2100
France	0825 010 700*
	*0.125 €/minute
Germany	49 (0) 7031 464 6333
Ireland	1890 924 204
Israel	972-3-9288-504/544
Italy	39 02 92 60 8484
Netherlands	31 (0) 20 547 2111
Spain	34 (91) 631 3300
Sweden	0200-88 22 55
United Kingdom	44 (0) 118 927 6201

For other unlisted countries:

www.agilent.com/find/contactus

Revised: January 6, 2012

Product specifications and descriptions in this document subject to change without notice.

© Agilent Technologies, Inc. 2012
Published in USA, October 2, 2012
5989-8115EN

