

Agilent B2961A/B2962A 6.5 Digit Low Noise Power Source

1 ch/2 ch
210 V, 3 A DC/10.5 A Pulse, 31.8W
100 nV/10 fA Resolution

Data Sheet



A revolutionary power supply for precision low noise voltage/current sourcing featuring 6.5 digit, 100 nV/10 fA resolution, 10 μ Vrms noise, bipolar 210 V/3 A (10.5 A pulse) range, innovative sourcing functions, and GUI

- The world's only 6.5 digit resolution power source with a bipolar sourcing range from 100 nV to 210 V and 10 fA to 3 A (DC)/10.5 A (pulsed).
- Optional ultra-low noise filters can reveal your device's true characteristics with low noise performance (10 μ Vrms from 10 Hz to 20 MHz, 1 nVrms/ $\sqrt{\text{Hz}}$ @10 kHz).
- Supports both pre-defined and user-defined arbitrary waveform generation (1 mHz to 10 kHz)
- Output voltage and current can be verified quickly using the built-in 4.5 digit voltage/current monitor
- Output voltage and current can be checked graphically on the B2900A's 4.3" LCD front panel display using the time-domain voltage/current waveform viewer.
- Programmable output resistance feature enables the emulation of a wide variety of DC voltage and current characteristics, such as driver ICs, regulators, energy generating devices, etc.
- Free application software for easy PC-based instrument control
- LXI Core conformant, USB2.0, GPIB, LAN and digital I/O interface



Introduction

The general trend in electronics is for equipment and devices to become smaller, integrated and more portable. More intelligence, integration and miniaturization are demanded along with lower power consumption to maximize battery life. Researchers, designers and developers pursuing the innovations and breakthroughs needed to develop these next-generation devices typically require basic equipment such as power supplies and sources for this work. Therefore, the power supplies and sources used by these innovators also need to possess features advanced enough to meet the difficult measurement challenges they often face. The Agilent B2900A series of precision instruments includes two next generation of power supply/source solutions that meet these needs: the B2961A 6.5 Digit Low Noise Power Source 1ch and the B2962A 6.5 Digit Low Noise Power Source 2ch. These products achieve best in class precision, support wide bipolar output ranges and have an extremely low noise floor. They also possess graphing capability and other advanced features. This makes them ideal companion products for other instruments such as oscilloscopes, network analyzers, spectrum analyzers, frequency counters, digital multi meters, nano-voltmeters, etc.

The world's only 6.5 digit source with a bipolar range of 100 nV to 210 V and 10 fA to 10.5 A

The Agilent B2961A/B2962A Power Source has broad voltage (up to ± 210 V) and current (up to ± 3 A DC and ± 10.5 A pulsed) sourcing ranges and excellent 6.5 digit resolution (minimum 100 nV/10fA program resolution). Unlike a typical power supply/source, it supports 4-quadrant operation that gives you the freedom to accurately and precisely supply any voltage or current contained within its ranges regardless of polarity.

Noise floor of 10 μ Vrms (1 nVrms / $\sqrt{\text{Hz}}$ @10 kHz) outperforms even linear power supplies

Low noise performance is required for the development of noise sensitive devices such as VCOs (voltage controlled oscillators), ADC/DAC, new material based components, etc. However, conventional power supplies and sources have not been able to achieve the noise level required for these applications. The Agilent B2961A/B2962A supports an optional external low noise filter that enables ultra-low noise performance down to 10 μ Vrms and 1nVrms/ $\sqrt{\text{Hz}}$ (at 10 kHz), providing unparalleled low noise performance in a low-cost bench-top power source.

Innovative sourcing capabilities enable test and evaluation not possible with conventional power supplies and sources

The Agilent B2961A/B2962A supports a number of innovative sourcing capabilities for test and evaluation that are not available on conventional power supplies and sources. For example, the Agilent B2961A/B2962A has the ability to generate not only DC signals but also pulsed, swept and arbitrary waveforms (1 mHz to 10 kHz) in both voltage and current. Its arbitrary waveform generation capability supports common waveform types such as sine, ramp, square, etc. in addition to user-defined waveforms.

The Agilent B2961A/B2962A also supports an advanced programmable output resistance feature that allows you to specify either a particular output resistance or a specific voltage versus current source characteristic. This feature is ideal for emulating a wide variety of devices (such as batteries, photovoltaic cells, sensors, transducers, etc.) that are otherwise difficult to simulate.

Finally, the Agilent B2961A/B2962A has a 4.3 inch wide LCD display and all of its capabilities are accessible from its front-panel graphical user interface (GUI). The graphical display not only simplifies user-operation, but it also facilitates viewing measurement results. With the built-in 4.5 digit voltage and current monitoring capability, you can check the output voltage or current graphically by the time domain voltage/current waveform viewer. This permits quick checking and debugging of measurement results without the need for additional equipment.

Key Specifications of B2900A Series

		B2961A/B2962A	B2961A/B2962A with Ultra Low Noise Filter	B2961A/B2962A with Low Noise Filter	
Number of channels		1 or 2	1 or 2	1 or 2	
Output	DC or arbitrary waveform output	Maximum voltage	210 V	± 42 V	210 V
		Maximum current	± 3.03 A	± 105 mA	± 3.03 A
	Pulsed	Maximum voltage	± 200 V	± 42 V	± 200 V
		Maximum current	± 10.5 A	± 105 mA	± 3.03 A ³
	Maximum Power	31.8 W	4.4 W	31.8 W	
Output Polarity	Bipolar (4-quadrant operation)	Bipolar (4-quadrant operation)	Bipolar (4-quadrant operation)		
Source Resolution	Digit	6.5 digit	6.5 digit	6.5 digit	
	Minimum resolution	100 nV/10 fA	100 nV/10 pA	100 nV/10 pA	
Output Capability	DC	Yes	Yes	Yes	
	Pulsed	Yes	only voltage output	only voltage output	
	Sweep DC/Pulse/List	Yes	only voltage output	only voltage output	
	Arbitrary wave form	Yes	only voltage output	only voltage output	
Noise ¹	0.1 to 10 Hz	< 5 µVpp < 1 pApp	< 5 µVpp < 1 pApp	< 5 µVpp < 1 pApp	
	10 to 20 M Hz	3 mVrms	10 µVrms (1nVrms/√Hz @ 10 kHz)	350 µVrms	
Measurement Capability		4.5 digit built-in voltage/current monitor	4.5 digit built-in voltage/current monitor	4.5 digit built-in voltage/current monitor	
Source/Monitor Ranges	Voltage range	200 mV to 200 V	200 mV to 200 V ²	200 mV to 200 V	
	Current range	10 nA to 10 A	10 µA to 100 mA	10 µA to 3 A	
Programmable Output Resistance	Constant R	Yes	No	No	
	V/I emulation	Yes	No	No	
View Mode	Single View	Yes	Yes	Yes	
	Waveform Preview	Yes	Yes	Yes	
	Dual View	Only 2ch model (B2962A)	Only 2ch model (B2962A)	Only 2ch model (B2962A)	
	Graph View (time-domain voltage/current waveform viewer)	Yes	Yes	Yes	
Max Capacitive Lead		0.01 µF (normal mode)	50 µF	1 mF	
Interface		GPIB, USB 2.0, LAN and digital I/O (LXI Core Conformant)	GPIB, USB 2.0, LAN and digital I/O (LXI Core Conformant)	GPIB, USB 2.0, LAN and digital I/O (LXI Core Conformant)	

1. Supplemental characteristics.

2. Maximum voltage output is limited to 42 V for 200 V range.

3. 10 A pulse range is not supported.

Specifications

Specification conditions

The source and measurement accuracy are specified under the conditions listed below.

1. Temperature: 23 °C ± 5 °C
2. Humidity: 30 % to 80 % RH
3. After 60 minutes warm-up
4. Ambient temperature change less than ±3 °C after self-calibration execution
5. Calibration period: 1 year
6. Measurement speed: 1 PLC (Power Line Cycle)

Maximum voltage and current

	Maximum Voltage	Maximum Current
DC, Pulsed or Arbitrary Waveform Output ¹	210 V	0.105 A
	21 V	1.515 A ²
	6 V	3.03 A ²
Pulsed only ¹	200 V	1.515 A
	6 V	10.5 A

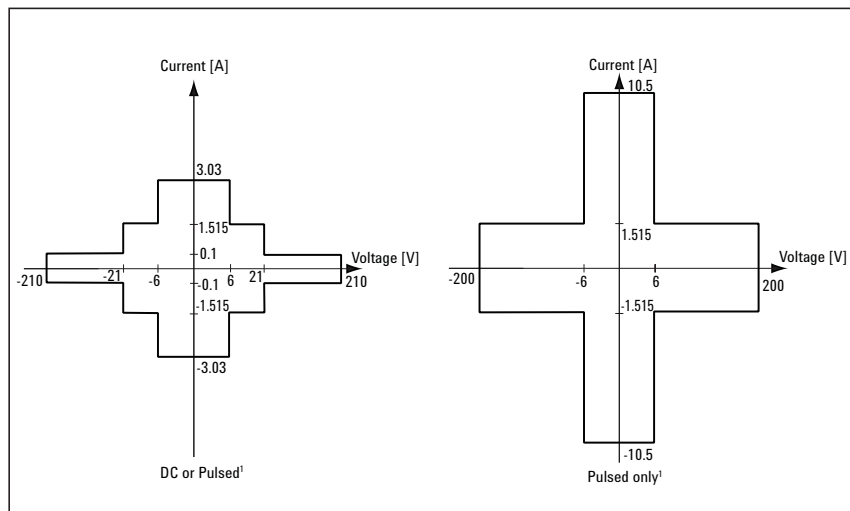

1. See "Maximum pulse width and duty cycle" in Pulse Source Supplemental Characteristics for applicable maximum voltage and current.
2. Maximum current limitation: For 21 V/1.515 A and 6 V / 3.03 A ranges, total maximum current is limited by the table below for using 2 channels. Maximum current is not limited for using 1 channel only.

Maximum current limitation

Ch1 voltage	Ch2 voltage	Max total current limitation of Ch1 and Ch2
±(0 V < V ≤ 6 V)	±(0 V < V ≤ 6 V)	Ch1 current + Ch2 current ≤ 4 A
±(0 V < V ≤ 6 V)	±(6 V < V ≤ 21 V)	Ch1 current + Ch2 current × 1.6 ≤ 4 A
±(6 V < V ≤ 21 V)	±(0 V < V ≤ 6 V)	Ch1 current + Ch2 current × 0.625 ≤ 2.5 A
±(6 V < V ≤ 21 V)	±(6 V < V ≤ 21 V)	Ch1 current + Ch2 current ≤ 2.5 A

Source Specifications

DC Voltage source specifications

Range	Programming Resolution	Accuracy (% reading + offset)	Noise (peak to peak) 0.1 Hz to 10 Hz ¹	Maximum Voltage (over range)
±200 mV	100 nV	±(0.015 % + 225 µV)	≤ 5 µV	±210 mV
±2 V	1 µV	±(0.02 % + 350 µV)	≤ 15 µV	±2.1 V
±20 V	10 µV	±(0.015 % + 5 mV)	≤ 150 µV	±21 V
±200 V	100 µV	±(0.015 % + 50 mV)	≤ 1.5 mV	±210 V

1. Supplemental characteristics

DC Current source specifications

Range	Programming Resolution	Accuracy (% reading + offset)	Noise (peak to peak) 0.1 Hz to 10 Hz ¹	Maximum Current (over range)
±10 nA	10 fA	±(0.10 % + 50 pA)	≤ 1 pA	±10.5 nA
±100 nA	100 fA	±(0.06 % + 100 pA)	≤ 2 pA	±105 nA
±1 µA	1 pA	±(0.025 % + 500 pA)	≤ 20 pA	±1.05 µA
±10 µA	10 pA	±(0.025 % + 1.5 nA)	≤ 60 pA	±10.5 µA
±100 µA	100 pA	±(0.02 % + 25 nA)	≤ 1 nA	±105 µA
±1 mA	1 nA	±(0.02 % + 200 nA)	≤ 6 nA	±1.05 mA
±10 mA	10 nA	±(0.02 % + 2.5 µA)	≤ 100 nA	±10.5 mA
±100 mA	100 nA	±(0.02 % + 20 µA)	≤ 600 nA	±105 mA
±1 A	1 µA	±(0.03 % + 1.5 mA)	≤ 20 µA	±1.05 A
±1.5 A	1 µA	±(0.05 % + 3.5 mA)	≤ 20 µA	±1.515 A
±3 A	10 µA	±(0.4 % + 7 mA)	≤ 60 µA	±3.03 A
±10 A ²	10 µA	±(0.4 % + 25 mA) ³		±10.5 A

1. Supplemental characteristics

2. 10 nA range is available only for pulse mode, not available for DC mode.

3. Measurement speed: 0.01 PLC

Source Supplemental Characteristics

Pulsing Capabilities

Minimum programmable pulse width: 50 μ s

Pulse width programming resolution: 1 μ s

Pulse width definition:

The time from 10 % leading to 90 % trailing edge as follows.

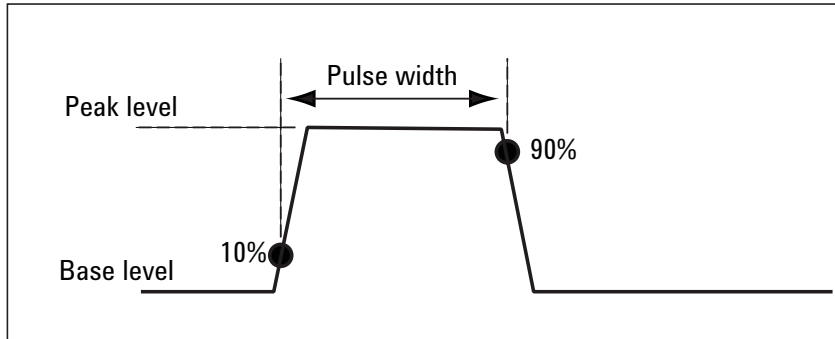

Maximum pulse width and duty cycle:

	Pulsed					DC	
	Maximum Voltage	Maximum Peak Current	Maximum Base Current	Pulse Width	Maximum Duty Cycle	Maximum Voltage	Maximum Current
DC or pulsed	210 V	0.105 A	0.105 A	50 μ s to 99999.9 s	99.9999 %	210 V	0.105 A
	21 V	1.515 A ¹	1.515 A ¹	50 μ s to 99999.9 s	99.9999 %	21 V	1.515 A ¹
	6 V	3.03 A ¹	3.03 A ¹	50 μ s to 99999.9 s	99.9999 %	6 V	3.03 A ¹
Pulsed only	200 V	1.515 A	50 mA	50 μ s to 2.5 ms	2.5 %		
	180 V	1.05 A	50 mA	50 μ s to 10 ms	2.5 %		
	6 V	10.5 A	0.5 A	50 μ s to 1 ms	2.5 %		

1. Maximum current limitation: For 21 V/1.515 A and 6 V / 3.03 A ranges, total maximum current is limited by the table in page 3 for using 2 channels. Maximum current is not limited for using 1 channel only.

Minimum pulse width at the given voltage, current and settling conditions:

Source Value	Limit Value	Load	Source Settling (% of range)	Minimum Pulse Width
200 V	1.5 A	200 Ω	0.1 %	1 ms
6 V	10.5 A	0.6 Ω	0.1 %	0.2 ms
1.5 A	200 V	65 Ω	0.1 %	2.5 ms
10.5 A	6 V	0.5 Ω	0.1 %	0.2 ms

Sweep Capabilities

Sweep mode: linear, logarithmic (log) or list

Sweep direction: single or double

Type: DC, or pulse

Number of steps: 1 to 100,000

Min programmable value to create list sweep waveform:

Minimum 10 μ s with 1 μ s resolution

Arbitrary Waveform Generation Capabilities

Pre-defined waveforms and user-defined waveforms are supported.

Pre-defined waveforms:

Supported waveforms: Sine, Square, Ramp, Triangle, Trapezoid and Exponential

Frequency: 1 mHz to 10 kHz

Programmable frequency/timing resolution: 1 μ Hz nominal (sine), 250 ns (waveforms other than sine)

Frequency accuracy of time base: ± 50 ppm

User-defined waveforms:

Waveform length: 1 to 100,000 points

Sample rate: 0.001 to 100,000 Sa/s, 250 ns resolution

Storage: Non-volatile memory and USB memory are both available.

Non-volatile memory can store one waveform with a length of up to 2500 points. USB memory can store waveforms of up to 100k points.

Output Characteristics

Temperature coefficient (0 °C to 18 °C and 28 °C to 50 °C):

$\pm(0.1 \times \text{Accuracy specification}) / ^\circ\text{C}$.

Max output power and source/sink limits:

31.8 W

$\pm 6 \text{ V} @ \pm 3.03 \text{ A}$, $\pm 21 \text{ V} @ \pm 1.515 \text{ A}$, $\pm 210 \text{ V} @ \pm 105 \text{ mA}$, four quadrant source or sink operation.

Output location: Channel 1 at front, and channel 2 at rear.

Output connectors:

Banana jack. Triaxial connections are recommended for sourcing less than 1 nA. A banana jack to triaxial adapter is available for low current source.

Low terminal connection: Chassis grounded or floating

Sensing Modes: 2-wire or 4-wire (Remote-sensing) connections

Maximum load:

Normal mode: 0.01 μF

High Capacitance mode: 50 μF

DC floating voltage: Maximum $\pm 250 \text{ V}$ DC between low force and chassis ground.

Guard offset voltage (V source): $< 4 \text{ mV}$

Remote sense operation range:

Maximum voltage between High Force and High Sense = 3 V

Maximum voltage between Low Force and Low Sense = 3 V

Common mode isolation: $> 1 \text{ G}\Omega$, $< 4500 \text{ pF}$

Maximum sense lead resistance: 1k Ω for rated accuracy

Sense input impedance: $> 10 \text{ G}\Omega$

Current limit/compliance:

Accuracy is same as current source. Minimum value is 1 % of range, or 1 nA in 10 nA range.

Voltage limit/compliance:

Accuracy is same as voltage source. Minimum value is 1 % of range, or 20 mV in 200 mV range

Over range:

101 % of source range for 1.5 A and 3 A ranges. 105 % of source range other than 1.5 A and 3 A ranges. No over range for 200 V range with current exceeding 105 mA pulse only condition.

Over temperature protection:

Output turns off then resets at over temperature sensed internally.

Voltage Source:

Settling time:

Time required to reach 0.1 % of final value at open load condition.

Step is 10 % to 90 % range.

Voltage Range	Settling Time
200 V	$< 50 \mu\text{s}$
2 V	$< 50 \mu\text{s}$
20 V	$< 110 \mu\text{s}$
200 V	$< 700 \mu\text{s}$

Slew rate/small signal bandwidth

Current range	Voltage Range				Load Resistance
	200 mV	2 V	20 V	200 V	
1 mA	44 mV/μs, 28 kHz	57 mV/μs, 18 kHz	57 mV/μs, 28 kHz	57 mV/μs, 28 kHz	10 MΩ
10 mA	44 mV/μs, 28 kHz	360 mV/μs, 20 kHz	360 mV/μs, 17 kHz	360 mV/μs, 28 kHz	10 MΩ
100 mA	28 mV/μs, 28 kHz	28 mV/μs, 20 kHz	28 mV/μs, 28 kHz	57 mV/μs, 28 kHz	10 MΩ
1 A	25 mV/μs, 28 kHz	25 mV/μs, 28 kHz	25 mV/μs, 28 kHz		10 MΩ
1.5 A	36 mV/μs, 28 kHz	36 mV/μs, 18 kHz	36 mV/μs, 28 kHz		10 MΩ
3 A	27 mV/μs, 28 kHz	27 mV/μs, 28 kHz	27 mV/μs, 28 kHz		10 MΩ

Note: Slew rate and small signal bandwidth can be down to -20% in maximum.

Noise 10 Hz to 20 MHz : < 3 mVrms, 20 V range, without external filter

V source overshoot:

< ±(0.1 % + 10 mV). Step is 10 % to 90 % range, resistive load.

Voltage source range change overshoot:

≤ 250 mV. 100 kΩ load, 20 MHz bandwidth

Line regulation/load regulation: Included in voltage source specifications.

Load transient recovery time

Time to recover to within the settling band following a load change.

	100 mA current change ¹	800 mA current change ²
Settling band	±20 mV	±20 mV
Time	10 μs	30 μs

1. At a load change to change the flowing current from +50 mA to +150 mA, 10 V voltage force, 20 V range, 1 A limit.

2. At a load change to change the flowing current from +100 mA to +900 mA, 10 V voltage force, 20 V range, 1.5 A limit.

Current Source:

Settling time:

Time required to reach within 0.1 % (0.3 % for 3 A range) of final value at short condition.

Step is 10 % to 90 % range.

Current Range	Settling Time
10 nA	<10 ms
100 nA	<10 ms
1 μA	<500 μs
10 μA	<250 μs
100 μA	<250 μs
1 mA	<80 μs
10 mA	<80 μs
100 mA	<80 μs
1 A	<80 μs
1.5 A	<80 μs
3 A	<80 μs

Slew rate/small signal bandwidth

Current range	Voltage Range				Load Resistance
	200 mV	2 V	20 V	200 V	
1 mA	94 $\mu\text{A}/\mu\text{s}$, 21 kHz	160 $\mu\text{A}/\mu\text{s}$, 21 kHz	160 $\mu\text{A}/\mu\text{s}$, 21 kHz	150 $\mu\text{A}/\mu\text{s}$, 21 kHz	100 Ω
10 mA	94 $\mu\text{A}/\mu\text{s}$, 21 kHz	670 $\mu\text{A}/\mu\text{s}$, 21 kHz	900 $\mu\text{A}/\mu\text{s}$, 21 kHz	900 $\mu\text{A}/\mu\text{s}$, 21 kHz	100 Ω
100 mA	8 mA/ μs , 10 kHz	8 mA/ μs , 10 kHz	8 mA/ μs , 10 kHz	12 mA/ μs , 21 kHz	1 Ω
1 A	78 mA/ μs , 12 kHz	94 mA/ μs , 12 kHz	92 mA/ μs , 12 kHz		0.1 Ω
1.5 A	125 mA/ μs , 12 kHz	135 mA/ μs , 12 kHz	140 mA/ μs , 12 kHz		0.1 Ω
3 A	250 mA/ μs , 13 kHz	270 mA/ μs , 13 kHz	260 mA/ μs , 13 kHz		0.041 Ω

Note: Slew rate and small signal bandwidth can be down to -20% in maximum.

I source overshoot:

< $\pm 0.1\%$ (< $\pm 0.3\%$ for 3 A range). Step is 10 % to 90 % range, resistive load.

Current source range change overshoot:

$\leq 250\text{ mV}/R\text{ load}$, 20 MHz bandwidth

Line regulation/load regulation: Included in current source specifications.

High Capacitance Mode

The high capacitance mode supports sources and measurements when the load capacitance is greater than 0.01 μF . In high capacitance mode the maximum allowed load capacitance value is 50 μF .

Voltage output settling time:

Time required to reach within 0.1 % of final value with 4.7 μF capacitive load on a fixed range at specified current range and limit value.

200 mV, 2 V Ranges: 600 μs , at 1 A limit

20 V Range: 1.5 ms, at 1 A limit

200 V Range: 20 ms, at 100 mA limit

Current measurement settling time:

Time required to reach 0.1 % of the final value after the voltage source stabilizes in a fixed range. V_{out} is 5 V unless noted.

1 μA Range: 230 ms

10 μA , 100 μA Ranges: 23 ms

1 mA, 10 mA Ranges: 0.23 ms

100 mA to 3 A Ranges: 100 μs

Mode change delay:

Delay into High Cap mode:

1 μA Range: 230 ms

10 μA , 100 μA Ranges: 23 ms

1 mA to 3 A Ranges: 1 ms

Delay out of High Cap mode:

All ranges: 10 ms

Noise 10 Hz to 20 MHz (20 V range): 4.5 mVrms

Voltage source range change overshoot (20 V range or below):

< 250 mV, 20 MHz bandwidth

High Capacitance mode working conditions:

V/I mode: Voltage source mode only

Range: Current measurement range is limited to fixed range only. 10 nA and 100 nA ranges are not available.

Current limit: $\geq 1\ \mu\text{A}$

Programmable Output Resistance

In its default state the Agilent B2961A/B2962A behaves like either an ideal voltage source with a negligibly small source resistance or an ideal current source with a huge source resistance. The programmable output resistance feature allows you to specify either a particular output resistance or a specific voltage versus current source characteristic. This feature is ideal for emulating a wide variety of devices (such as batteries, photovoltaic cells, sensors, transducers, etc.) that are otherwise difficult to simulate.

Mode: Constant or V/I Emulation

Programmable resistance range:

Series resistance (R_s) at voltage source:

- $(\text{Load Resistance}/2) \leq R_s \leq \text{Load Resistance}$, for resistive load
- $R_s \leq 25 \Omega$ at 3 A range, $\leq 100 \Omega$ at 1 A and 1.5 A ranges, $\leq 1 \text{ k}\Omega$ at 100 mA range, or $\leq 10 \text{ k}\Omega$ at other ranges,
- R_s can be limited by capacitive load.

Shunt resistance (R_{sh}) at current source:

- $\text{Load Resistance} \leq R_{sh} \leq 2 \text{ G}\Omega$, for resistive load
- $R_{sh} \geq 10 \text{ M}\Omega$ at 10 nA and 100 nA ranges, $\geq 1 \text{ M}\Omega$ at other ranges
- R_{sh} can be limited by capacitive load.

Emulation mode:

Emulation mode allows you to program a non-linear resistance. You specify the desired voltage/current characteristic using a tabular format.

Maximum number of points: 16 (piecewise linear interpolation between points)

* Programmable Output Resistance is only available for DC output.

External Low Noise Filter Supplemental Characteristics

The Agilent B2961A/B2962A supports dedicated external low-noise filters; they are available as an option or as an accessory. They connect to the banana jack outputs of each Agilent B2961A/B2962A channel.

Ultra Low Noise Filter (N1294A-021)

Maximum output range: 42 V / 105 mA (DC)

Output connector: BNC

Output / residual resistance: 50 Ω nominal (2-wire), 0.3 Ω nominal (4-wire, 4-wire connected inside of filter)

Small signal bandwidth: 23 Hz nominal (2-wire), 8 Hz nominal (4-wire)

Noise

Voltage source

0.1 to 10 Hz: Same as voltage specification

10 to 20 MHz : 10 μVrms , 1 $\text{nVrms}/\sqrt{\text{Hz}}$ at 10 kHz (20 V / 100 mA range, 50 Ω load)

Current source

0.1 to 10 Hz: Same as current specification

10 to 1 MHz : 300 nArms (20 V / 100 mA range, 10 Ω load)

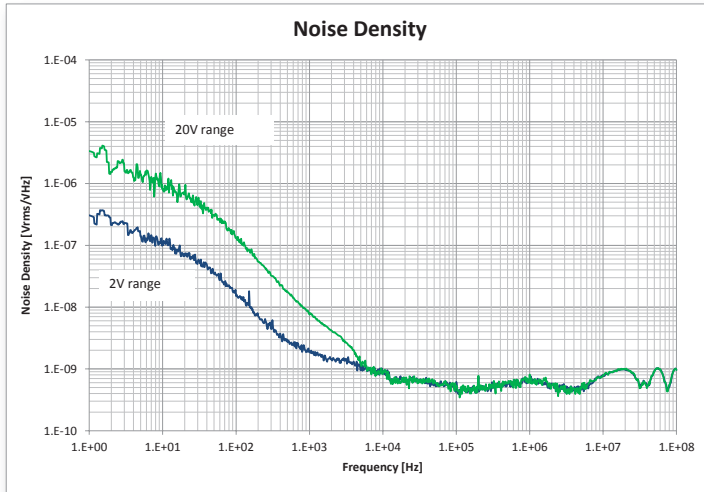

Settling time

Voltage source ¹: 80 ms (2-wire), 140 ms (4-wire)

Current source ²: 11 ms (2-wire), 150 ms (4-wire)

1. Time required to reach within 0.1 % of final value at open load condition. Step is 10 % to 90 % range. At 20 V range, 100 mA limit/100 mA range
2. Time required to reach within 0.1 % of final value at short condition. Step is 10 % to 90 % range. At 100 mA range, 20 V limit / 20V range

Load transient recovery time

Time to recover to within the settling band following a load change.

50 mA current change ¹	
Settling band	± 20 mV
Time	50 ms (2-wire), 85 ms (4-wire)

1. At a load change to change the flowing current from +10 mA to +60 mA, 10 V voltage force, 20 V range, 100 mA limit.

Supported ranges:

Voltage: 200 mV to 200 V ranges (42 V maximum)

Current: 10 μA to 100 mA ranges (105 mA maximum)

Maximum capacitive load: 50 μF (for 4-wire)

Dimensions: 41 mm H x 58.2 mm W x 141.5 mm D (When the filter is inserted to the output connector of B2961A/B2962A, the depth is 126.5 mm.)

Weight: 0.3 kg

Note:

- * The 10 A pulse range and programmable output resistance capability are not supported by external filters.
- * For the current output, only DC is supported when using with external filters.
- * The current measurement data monitored by the built-in voltage/current monitor can be influenced by the charge and discharge current of the capacitance inside of the filters.

Low Noise Filter (N1294A-022)

Maximum output range: 210 V / 3 A (DC)

Output connector/connection: Banana, 2-wire/4-wire

Output / residual resistance: 0.3 Ω nominal (2-wire)

Small signal bandwidth: 2 kHz nominal (1 A and 3 A ranges), 800 Hz nominal (100 mA range)

Noise

Voltage source

0.1 to 10 Hz: Same as voltage specification

10 to 20 MHz : 350 μ Vrms (20 V / 1.5 A range, 50 Ω load)

Current source

0.1 to 10 Hz: Same as current specification

10 to 1 MHz : 450 μ Arms (20 V / 1.5 A range, 0.67 Ω load)

Settling time

Voltage source ¹: 640 μ s (2-wire/4-wire)

Current source ²: 1.2 ms (2-wire/4-wire)

1. Time required to reach within 0.1 % of final value at open load condition. Step is 10 % to 90 % range. At 20 V range, 1.5 A limit/1.5 A range

2. Time required to reach within 0.1 % of final value at short condition. Step is 10 % to 90 % range. At 1.5 A range, 20 V limit / 20V range

Load transient recovery time

Time to recover to within the settling band following a load change.

800 mA current change ¹	
Settling band	± 20 mV
Time	450 μ s (2-wire), 650 μ s (4-wire)

1. At a load change to change the flowing current from +100 mA to +900 mA, 10 V voltage force, 20 V range, 1.5 A limit.

Supported ranges:

Voltage: 200 mV to 200 V ranges (210 V maximum)

Current: 10 μ A to 3 A ranges (3 A maximum)

Maximum capacitive load: 1 mF

Dimensions: 41.5 mm H x 58.2 mm W x 127.5 mm D (When the filter is inserted to the output connector of B2961A/B2962A, the depth is 112.5 mm.)

Weight: 0.25 kg

Note:

* The 10 A pulse range and programmable output resistance capability are not supported by external filters.

* For the current output, only DC is supported when using with external filters.

*The current measurement data monitored by the built-in voltage/current monitor can be influenced by the charge and discharge current of the capacitance inside of the filters.

Built-in Voltage/Current Monitor Specifications

Voltage Measurement Specifications

Range	Measurement Resolution	Accuracy (% reading + offset)
±200 mV	10 µV	±(0.015 % + 225 µV)
±2 V	100 µV	±(0.02 % + 350 µV)
±20 V	1 mV	±(0.015 % + 5 mV)
±200 V	10 mV	±(0.015 % + 50 mV)

Current Measurement Specifications

Range	Measurement Resolution	Accuracy (% reading + offset)
±10 nA ¹	1 pA	±(0.10 % + 50 pA)
±100 nA	10 pA	±(0.06 % + 100 pA)
±1 µA	100 pA	±(0.025 % + 500 pA)
±10 µA	1 nA	±(0.025 % + 1.5 nA)
±100 µA	10 nA	±(0.02 % + 25 nA)
±1 mA	100 nA	±(0.02 % + 200 nA)
±10 mA	1 µA	±(0.02 % + 2.5 µA)
±100 mA	10 µA	±(0.02 % + 20 µA)
±1 A	100 µA	±(0.03 % + 1.5 mA)
±1.5 A	100 µA	±(0.05 % + 3.5 mA)
±3 A	1 mA	±(0.4 % + 7 mA)
±10 A ¹	1 mA	±(0.4 % + 25 mA) ²

1.10 A range is available only for pulse mode, not available for DC mode.

2.Measurement speed: 0.01 PLC

Built-in Voltage/Current Monitor Supplemental Characteristics

Temperature coefficient (0 °C to 18 °C and 28 °C to 50 °C):

$\pm(0.1 \times \text{Accuracy specification}) / ^\circ\text{C}$.

Over range :

102 % of measurement range for 1.5 A and 3 A ranges. 106 % of measurement range other than 1.5 A and 3 A ranges.

Voltage measurement range change overshoot:

< 250 mV. 100 k Ω load, 20 MHz bandwidth

Current measurement range change overshoot:

<250 mV/R load , 20 MHz bandwidth

Derating accuracy for measurement speed less than 1 PLC :

Add % of range using the following table for measurement with PLC <1.

Derating accuracy with PLC setting < 1 PLC

	Voltage Range		Current Range			
	0.2 V	2V to 200 V	10 nA	100 nA	1 μA to 100 mA	1 A to 3 A
0.1 PLC	0.01 %	0.01 %	0.1 %	0.01 %	0.01 %	0.01 %
0.01 PLC	0.05 %	0.02 %	1 %	0.1 %	0.05 %	0.02 %
0.001 PLC	0.5 %	0.2 %	5 %	1 %	0.5 %	0.2 %

Data Buffer

A data buffer is an array of measurement elements. Each element holds the following values.

- Source setting
- Time stamp
- Measurement value
- Status

Maximum buffer size: 100,000 points / channel

Triggering and Timing Specifications

Triggering

Digital I/O Trigger in to trigger out ¹: $\leq 5 \mu\text{s}$

Digital I/O Trigger in to source change ¹: $\leq 5 \mu\text{s}$

LXI Trigger in to source change ¹: Minimum 100 μs , Typical 200 μs , Maximum Unknown

LXI Trigger in to measurement ¹: Minimum 100 μs , Typical 200 μs , Maximum Unknown

Internal event to external LXI Trigger output ¹: Minimum 100 μs , Typical 200 μs , Maximum Unknown

LAN[0-7] Event Receiving Latency ¹: Unknown

LAN[0-7] Event Sending Latency ¹: Unknown

Minimum trigger interval: 10 μs

1. Supplemental Characteristics

Timer

Trigger timing resolution: 1 μs to 100 ms

Timer accuracy: ± 50 ppm

Arm/trigger delay: 0 to 100,000 s

Arm/trigger interval: 10 μs to 100,000 s

Arm/trigger event: 1 to 100,000

Time stamp: TIMER value automatically saved when each measurement is triggered.

General Specifications

Environment
For use in indoor facilities
Temperature Range
Operating: 0 °C to +55 °C
Storage: -30 °C to +70 °C
Humidity Range
Operating: 30 % to 80 % RH, non-condensing
Storage: 10 % to 90 % RH, non-condensing
Altitude
Operating: 0 m to 2000 m
Storage: 0 m to 4600 m
Power Supply
AC voltage: 90 V to 264 V
Line frequency: 47 Hz to 63 Hz
Maximum volt-amps: 250 VA
Cooling
Forced air. Side intake and rear exhaust.
EMC
IEC61326-1/EN61326-1
AS/NZS CISPR 11
KC: RRA Notification amending Radio Waves Act Article 58-2
Safety
IEC61010-1/EN61010-1
CAN/CSA-C22.2 No. 61010-1-04, C/US
Certifications
CE, cCSAus, C-Tick, KC
Dimensions
Without handle & feet: 88 mm H x 213 mm W x 450 mm D
Bench Configuration (with handle & feet): 180 mm H x 260 mm W x 480 mm D
Weight
B2961A: 5.0 kg
B2962A: 6.4 kg

Operation and Functions

Front Panel Interface

4.3" Color TFT WQVGA (480x272, with LED backlight) provides a graphical user interface (GUI) with the following features.

- Single, Dual View and time domain view (voltage vs. time or current vs. time) on Graph view
- Preview of output waveform
- Easy-to-use key operations
- Easy access to basic and advanced source/measurement capabilities

Single view

Single view provides basic and advanced settings and display capabilities for a selected channel from the front panel of the instrument. The DC, pulse and integrated arbitrary waveform generation capabilities do not require any additional controller or software. The GUI has a feature that allows you to preview an arbitrary waveform before application. It also displays the measured voltage and current for the selected channel with 4.5 digits of resolution.

Dual view

Dual view allows you to view both channels simultaneously and provides basic setting and display capabilities. It also displays the measured voltage and current for both channels 1 and 2 with 4.5 digits of resolution. This mode is available only for the B2962A

Graph view

Graph View displays measurement results in the time-domain (V-t or I-t curves) for up to 2 channels. This is useful for quick checking and debug of the output waveform(s).

Easy-to-use Key Operations

- Numeric/alpha keys, assist key and rotary knob for easy operation.
- Numeric/alpha keys enable direct input of alphanumeric values.
- Assist key guides operation on the front panel.

Easy Access to Source/Measurement Capabilities

Settings:

- V/I source mode
- Source value
- Limit (compliance) value
- Sweep parameters
- Pulse parameters
- Parameters for built-in waveform
- Measure speed
- Range setting
- Trigger setting

Displays:

- Numeric display in 6.5 digits for sourcing
- Numeric display in 4.5 digits for monitoring
- V-t/I-t curve in Graph View

Advanced Capabilities:

- Trace memory for accumulating measurement (or math) result and collecting their statistics

File Operations (USB memory):

- Save
- System Configuration
- Measurement/Math result
- Trace data
- Graph screen dump
- Load
- System configuration
- List sweep data / User-defined arbitrary waveform data

Program and Interface Capabilities

Programming Language

The Agilent B2961A/B2962A supports SCPI (Standard Commands for Programmable Instruments).

Program Memory

Program memory allows you to store long strings of SCPI command lines once into the B2961A/B2962A's volatile memory and then recall those strings multiple times while the program is executing using a single SCPI command. By storing the command strings in memory, the time that would have been spent sending those same commands over a communication bus is eliminated. For tests that utilize lots of repeated code (such as subroutines), program memory can dramatically reduce test times.

Maximum number of characters in program name:

32, consisting of alphabetic characters, numbers, hyphens and underscores.

Maximum memory size: 100 KB (2500 lines typical)

LXI

LXI Core Conformant. The Agilent B2961A/B2962A follows specified LAN protocols and adheres to LXI requirements such as a built-in Web control server and IVI-COM driver.

Ethernet: 10/100Base-T

USB2.0: USB-TMC488 protocol (Rear x 1)

GPIO: IEEE-488.2 compliant

USB file system

USB 2.0 high-speed mass storage (MSC) class device (Front x 1)

Digital I/O interface

Connector: 25-pin female D.

Input/output pins: 14 open drain I/O bits

Absolute maximum input voltage: 5.25 V

Absolute minimum input voltage: - 0.25 V

Logic low maximum input voltage: 0.8 V

Logic high minimum input voltage: 2.0 V

Maximum source current: 1 mA, Vout = 0 V

Maximum sink current: 50 mA, Vout = 5 V

5 V power supply pin:

Limited to 600 mA, solid state fuse protected.

Safety interlock pin:

One active high pin and one active low pin. Activation of both pin enables output voltage > 42 V.

Furnished accessories

Power cable

USB cable

Quick Reference (English)

Product Reference CD-ROM (including PDF manuals, Agilent B2900A Quick I/V Measurement Software and drivers)

Agilent I/O Library Suite

Software and drivers

Agilent B2900A Quick I/V Measurement Software

The Agilent B2961A/B2962A includes PC-based Agilent B2900A Quick I/V Measurement Software. This powerful software makes it easy to quickly setup and perform I/V measurements and to display the measurement data in a table

or graph without the need to perform any programming. The software allows you to control up to four channels over a GPIB or LAN connection, or one B2900A series unit via a USB connection.

Operating environment:

Operating System: Windows 7 (64bit/32bit), XP SP3 (32-bit).

Other requirements: Microsoft .NET framework 4.0 or greater, and IO Libraries 16.0 or greater.

Agilent B2900A Graphical Web Interface

The Agilent B2900A Graphical Web Interface is a web browser based instrument control panel. It enables you to set up and perform a measurement easily and quickly from a web browser using the Agilent B2961A/B2962A's built-in web server. This allows you to control one Agilent B2900A series unit over a LAN connection.

IVI-C or IVI-COM drivers

Compatible with Windows 7 (64bit/32bit), XP SP3 (32-bit) IO Libraries 16.0 or greater. Supports Agilent VEE, Microsoft Visual Studio (Visual Basic, Visual C++, Visual C#), National Instruments LabWindows and LabVIEW.

LabVIEW driver (VI)

National Instruments LabVIEW 7.0 or greater. LabView drivers are available at NI.COM.

Ordering Information

Model Number	
B2961A	6.5 Digit Low Noise Power Source, 32W, 210V, 3A, 1ch
B2962A	6.5 Digit Low Noise Power Source, 32W, 210V, 3A, 2ch
Options	
<i>External Low Noise Filter</i>	
LN1	Ultra Low Noise Filter, 42V/105mA, 50 Ω (N1294A-021)
LN2	Low Noise Filter, 210V/3A (N1294A-022)
<i>Printed Manual (User's Guide)</i>	
ABA	English
ABJ	Japanese
<i>Calibration</i>	
A6J	ANSI Z540 compliant calibration
UK6	Commercial calibration certificate with test data
<i>Rack Mount Kit</i>	
1CM	Rack mount kit
Accessories	
<i>Banana to Triaxial Adapter</i>	
N1294A-001	Banana - Triax Adapter for 2-wire (non Kelvin) connection
N1294A-002	Banana - Triax Adapter for 4-wire (Kelvin) connection
<i>External Low Noise Figure</i>	
N1294A-021	Ultra Low Noise Filter, 42V/105mA, 50 Ω
N1294A-022	Low Noise Filter, 210V/3A
<i>BNC Trigger Adapter</i>	
N1294A-031	GPIB-BNC Trigger Adapter



myAgilent

www.agilent.com/find/myagilent

A personalized view into the information most relevant to you.



www.lxistandard.org

LAN eXtensions for Instruments puts the power of Ethernet and the Web inside your test systems. Agilent is a founding member of the LXI consortium.

Agilent Channel Partners

www.agilent.com/find/Channelpartners

Get the best of both worlds: Agilent's measurement expertise and product breadth, combined with channel partner convenience.

If you need more measurement capabilities, the best choice is Agilent precision SMU products.



Agilent B2901A/B2902A/B2911A/
B2912A Precision Source/Measure
Units

www.agilent.com/find/precisionsmu



Agilent B1500A Semiconductor
Device Analyzer

www.agilent.com/find/B1500A



Agilent Advantage Services is committed to your success throughout your equipment's lifetime. To keep you competitive, we continually invest in tools and processes that speed up calibration and repair and reduce your cost of ownership. You can also use Infoline Web Services to manage equipment and services more effectively. By sharing our measurement and service expertise, we help you create the products that change our world.

www.agilent.com/find/advantageservices



www.agilent.com/quality

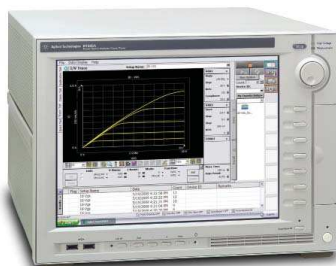

Agilent B1505A Power Device
Analyzer / Curve Tracer (40A / 3000V)
www.agilent.com/find/B1505A

www.agilent.com
www.agilent.com/find/b2900a

For more information on Agilent Technologies' products, applications or services, please contact your local Agilent office. The complete list is available at:

www.agilent.com/find/contactus

Americas

Canada	(877) 894 4414
Brazil	(11) 4197 3600
Mexico	01800 5064 800
United States	(800) 829 4444

Asia Pacific

Australia	1 800 629 485
China	800 810 0189
Hong Kong	800 938 693
India	1 800 112 929
Japan	0120 (421) 345
Korea	080 769 0800
Malaysia	1 800 888 848
Singapore	1 800 375 8100
Taiwan	0800 047 866
Other AP Countries	(65) 375 8100

Europe & Middle East

Belgium	32 (0) 2 404 93 40
Denmark	45 45 80 12 15
Finland	358 (0) 10 855 2100
France	0825 010 700*
	*0.125 €/minute
Germany	49 (0) 7031 464 6333
Ireland	1890 924 204
Israel	972-3-9288-504/544
Italy	39 02 92 60 8484
Netherlands	31 (0) 20 547 2111
Spain	34 (91) 631 3300
Sweden	0200-88 22 55
United Kingdom	44 (0) 118 927 6201

For other unlisted countries:

www.agilent.com/find/contactus

Revised: October 11, 2012

Product specifications and descriptions in this document subject to change without notice.

© Agilent Technologies, Inc. 2012
Published in USA, November 7, 2012
5991-0663EN



Agilent Technologies