

# Agilent N4391A Optical Modulation Analyzer

Measure with confidence

Your physical layer probe for vector modulated signals

Data Sheet



# Measure with Confidence

**The N4391A provides you the highest confidence in your test results.**

This is achieved by providing system performance specification measured with the same parameter as you will specify the quality of your signal. This gives you the confidence that then N4391A measurement results really show the signal and not the instruments performance. This can be verified by you with a very easy setup within minutes.

**The N4391A offers most sophisticated signal processing algorithms with highest flexibility**

The algorithms provided with the instrument

- Detection of single and dual polarized user signals
- Transparent to most modulation formats
- In-Channel CD and PMD measurement and compensation
- Easy and flexible adoption of algorithm internal parameters to your needs
- In line Matlab debugging capabilities

**The N4391A offers a powerful toolset to debug the most challenging errors, with tools proven by thousands of RF engineers**

The analysis software is based on the industry standard Agilent Vector Signal Analysis (VSA) software with extensions for the optical requirements like dual polarization data processing. This analysis software is the work horse in RF and mobile engineering labs and offers all tools needed to analyze complex modulated (or vector modulated) optical signals. It provides a number of parameters that qualifies the signal integrity of your measured signal. The most common one is the normalized geometric error of the Error Vector Magnitude (EVM) of up to 4096 symbols. In addition the functionality can be extended with math and macro functions according to your needs.

## Features and benefits

- Up to 33 GHz true analog bandwidth
- Up to 60 Gbaud symbol rate analysis capability
- Performance verification within minutes
- 4 times better noise floor than typical optical QPSK transmitters
- 4 channel polarization-diverse detection
- Real-time sampling for optimal phase tracking
- User selectable phase-tracking bandwidth.
- Specified instrument performance
- Support of modulation formats for 100G and upcoming terabit transmission
- Uses error vector concept well-accepted in the RF world
- No clock input or hardware clock recovery necessary
- Analyzes any PRBS or real data
- Real-time high resolution spectral analysis
- Laser line-width measurement
- Bit Error Analysis, even with polarization multiplexed signals
- CD and 1st-order PMD compensation and measurement.

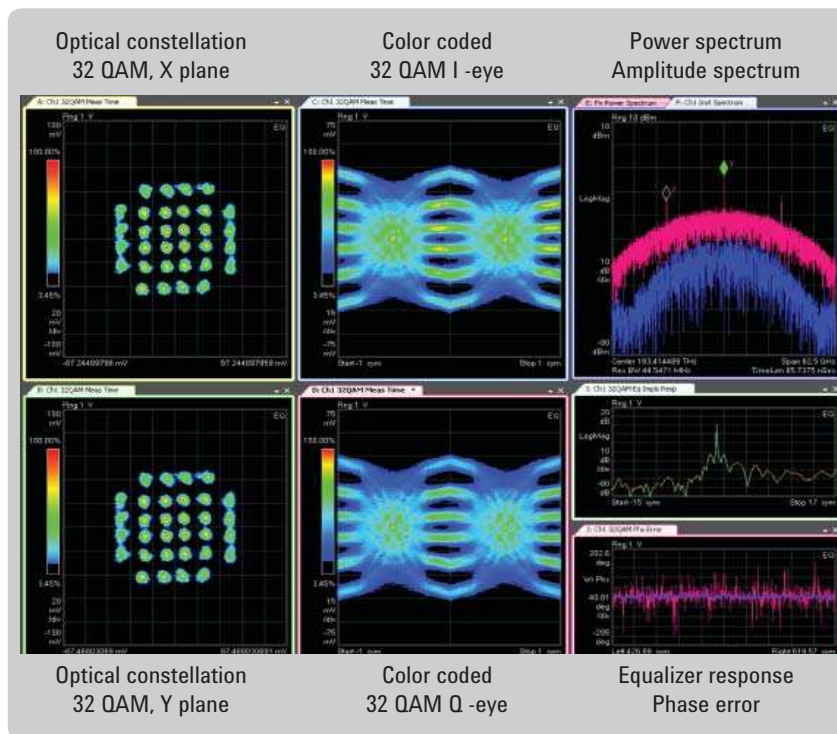

Figure 1.

# Transmitter Signal Qualification Application

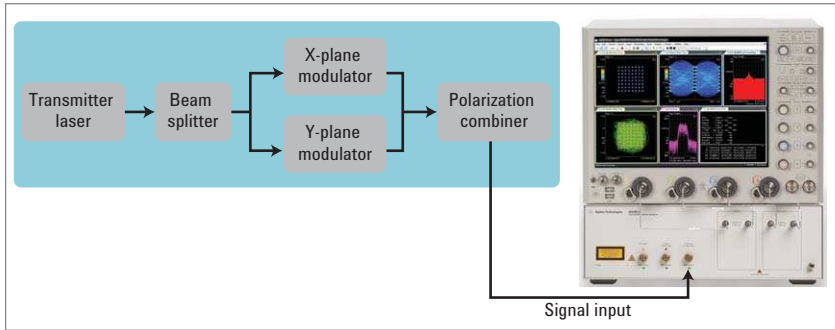

Figure 2.

Transmitter signal integrity characterization

- Transmitter performance verification
- Transmitter optimal alignment during manufacturing
- Transmitter vendor qualification
- Final pass fail test in manufacturing
- Evaluation of transmitter components for best signal fidelity

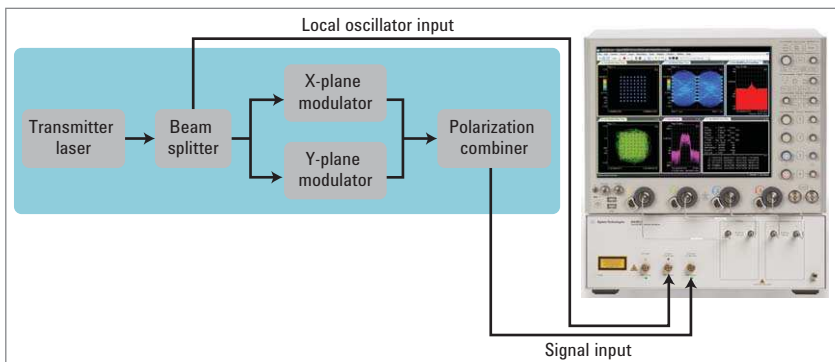

Figure 3.

Homodyne component characterization

- Component evaluation independent of carrier laser phase noise
- Modulator in system qualification
- Modulator-driver in-system amplifier performance verification
- Advanced debugging in R&D

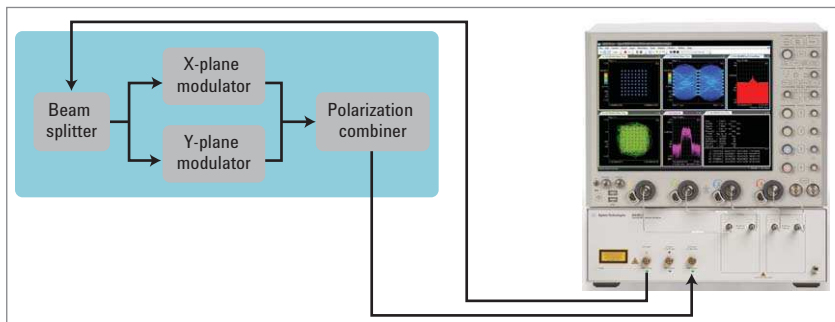

Figure 4.

Component evaluation

- Cost effective modulator evaluation
- Cost effective modulator driver evaluation
- Final specification test in application of IQ modulator
- Advanced research

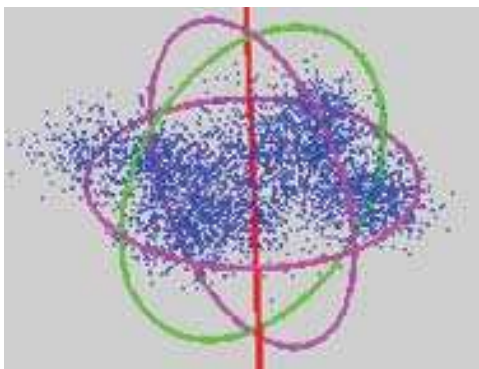

Figure 5.

Additional transmitter test applications

- Advanced research in highly efficient modulation formats
- Advanced debugging during development of a transmitter
- Carrier laser qualification
- BER verification at physical layer
- Signal analysis in Stokes-Space to verify polarization behavior of transmitter output. Figure 5 shows an example of an DP-QPSK signal distribution in the stokes space.

## Link Test Application

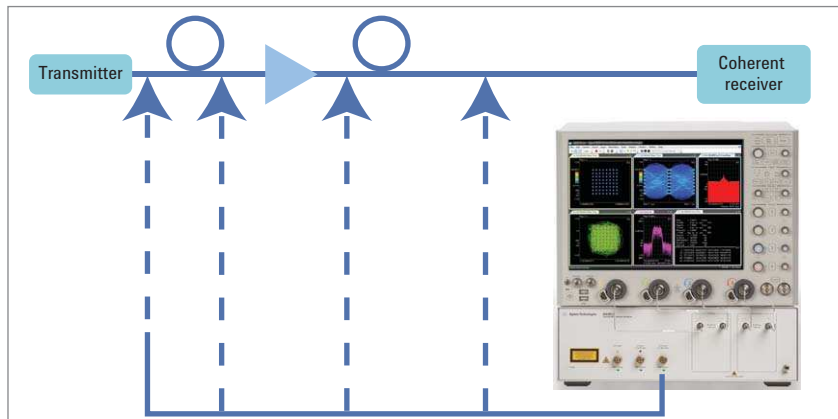

Figure 6.

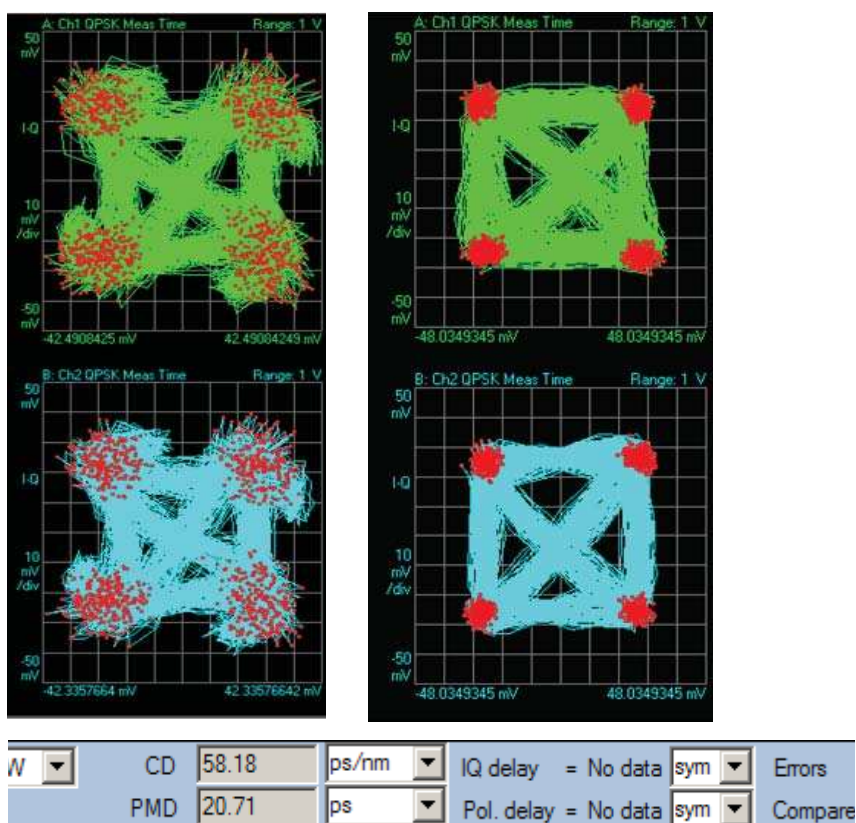

Figure 7. Left screen shot shows the signal before CD compensation, right screen show's the constellation after applying one of the available CD compensation algorithms.

### CD, PMD measurement

Impairments along an optical link will distort the received signal and are visible in a distorted constellation. Algorithms to compensate this very effectively in real time are under active research. The highly sophisticated CD and PMD algorithms of the N4391A are able not only to compensate for this distortion, but can also measure in-channel CD and first-order in-channel PMD.

### Link qualification

New tools allow optical links to be characterized by measuring the link impairments on the vector modulated signal. Research engineers and scientists, who are interested in characterization of the performance of an optical link, now get the tools at hand to characterize vector modulated signals along the link down to the receiver.

#### Tools for link test

- CD compensation
- In-channel CD measurement
- PMD compensation
- In-channel 1-st order PMD measurement
- Trigger mode (gating) for loop experiments
- Selection of 4 different CD compensation algorithms
- Selection of 4 different PMD algorithms
- Error vector magnitude measurements as figure of merit for signal quality
- Physical layer BER
- Support of user defined algorithms

By using these tools it is very easy to create diagrams showing the signal quality influenced by various link impairment such as CD, PMD, Loss or PDL. Even the effect of non-linear link impairments can be qualified with EVM.

## Algorithm Development

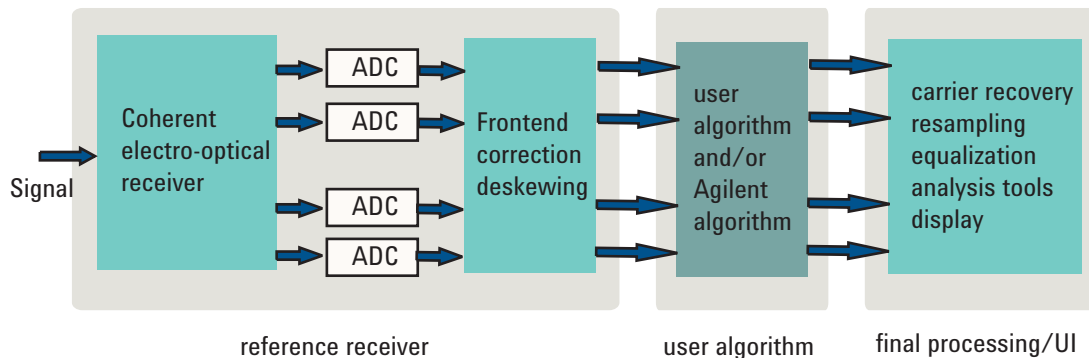

Figure 8. Principle of signal flow of the N4391A with reference receiver preprocessing, final processing, decoding and display.

### User algorithm integration

Being able to work with a well defined and specified reference system will speed up the development process of a coherent receiver significantly and leads to additional confidence in the test results. The algorithm development can be started even if the first hardware for the receiver under development is unavailable.

In Figure 7 the signal flow of the optical modulation analyzer is outlined. The reference receiver comprises the whole block covering coherent signal detection, analog-to-digital conversion and correction for all physical impairments coming from the optical hybrid and signal detection. This reflects a close to ideal receiver with up to 32 GHz true analog bandwidth.

This signal is the input to the data post processing system which can incorporate Agilent's provided algorithms and/or user algorithms. The sequence of the algorithm can be selected without limitation and can be changed during the measurement.

In addition, this nearly ideal reference raw data can now be recorded, stored and replayed for later analysis with different parameter settings or with a different user algorithm adding flexibility for the user for post-processing one time recorded data.

The programming environment can be any widely used tools like native C, C++ or Matlab®.

Templates for Matlab® and Visual C# programming environments are part of the instrument software to help get a running start with user algorithm.

## Algorithm Development (continued)

### User selectable polarization and phase tracking loop gain

The well known very flexible algorithm for polarization and phase tracking, that already work for all QAM, and PSK formats has been enhanced. Now the user can modify the loop gain of the polarization and phase tracking.

This allows the N4391A to measure with the same tracking gain as the user's receiver providing results closest to those of the final transmission system.

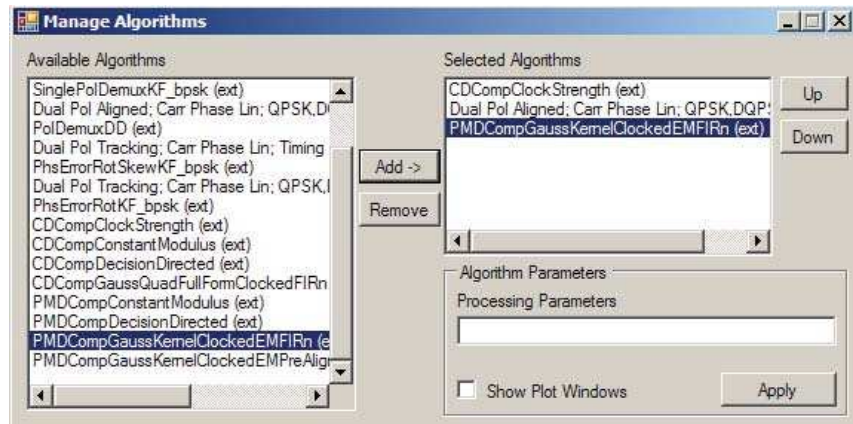

Figure 9. N4391A window to manage user and Agilent provided algorithm. In the right selection the sequence can be changed on the fly even during a running measurement.

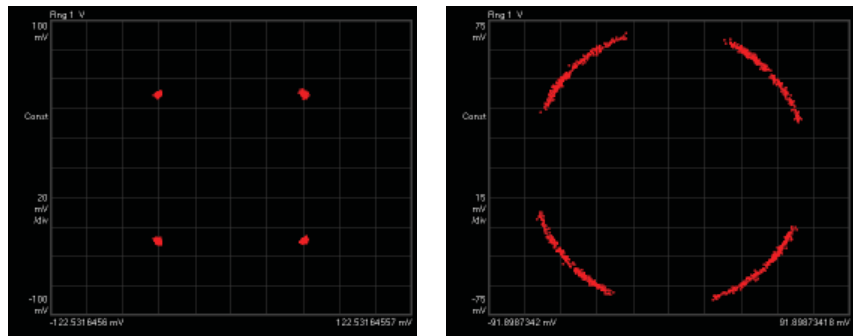

Figure 10. N4391A analysis with two different phase tracking loop gain settings of same input signal.

Phase tracking high loop gain

Phase tracking low loop gain

# Constellation and Eye Diagram Analysis

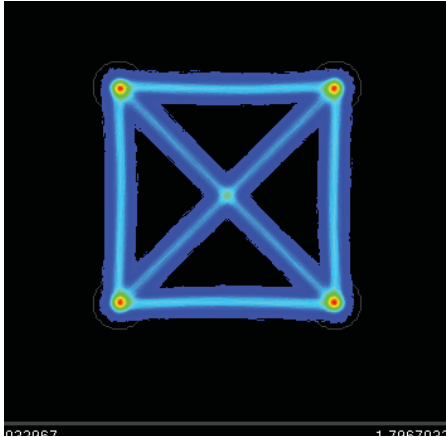

Figure 11.

## Optical I-Q diagram

The I-Q diagram (also called a polar or vector diagram) displays demodulated data, traced as the in-phase signal (I) on the x-axis versus the quadrature-phase signal (Q) on the y-axis. Color-coded display make complex data statistics clear and concise.

This tool gives deeper insight into the transition behavior of the signal, showing overshoot and an indication of whether the signal is bandwidth limited when a transition is not close to a straight line.

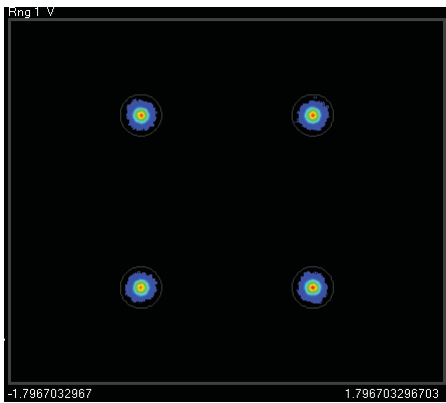

Figure 12.

## Optical constellation diagram

In a constellation diagram, information is shown only at specified time intervals. The constellation diagram shows the I-Q positions that correspond to the symbol clock times. These points are commonly referred to as detection decision-points, and are interpreted as the digital symbols. Constellation diagrams help identify such things as amplitude imbalance, quadrature error, or phase noise.

The constellation diagram gives fast insight into the quality of the transmitted signal as it is possible to see distortions or offsets in the constellation points. In addition, the offset and the distortion are quantified by value for easy comparison to other measurements.

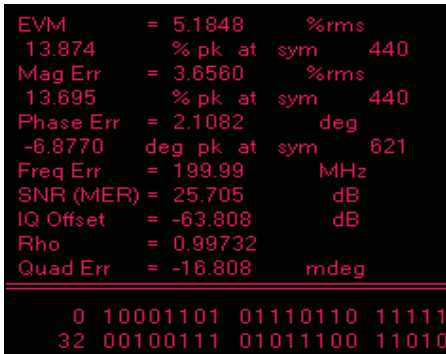

Figure 13.

## Symbol table/error summary

This result is one of the most powerful of the digital demodulation tools. Here, demodulated bits can be seen along with error statistics for all of the demodulated symbols. Modulation accuracy can be quickly assessed by reviewing the rms EVM value. Other valuable parameters are also reported as seen in the image below.

- I-Q offset
- Quadrature error
- Gain imbalance

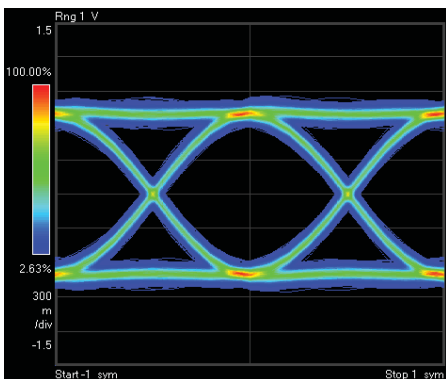

Figure 14.

## Eye diagram of I or Q signal

An eye diagram is simply the display of the I (real) or Q (imaginary) signal versus time, as triggered by the symbol clock. The display can be configured so that the eye diagram of the real (I) and imaginary (Q) part of the signal are visible at the same time.

Eye diagrams are well-known analysis tools for optical ON/OFF keying modulation analysis. Here, this analysis capability is extended to include the imaginary part of the signal.

# Signal Integrity and Bit Error Analysis Tools

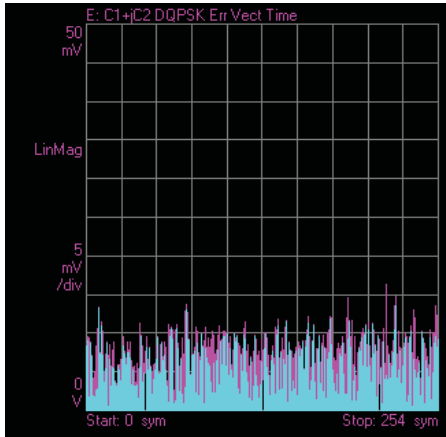

Figure 15.

## Error vector magnitude

The error vector time trace shows computed error vector between corresponding symbol points in the I-Q measured and I-Q reference signals. The data can be displayed as error vector magnitude, error vector phase, only the I component or only the Q component.

This tool gives a quick visual indication of how the signal matches the ideal signal.

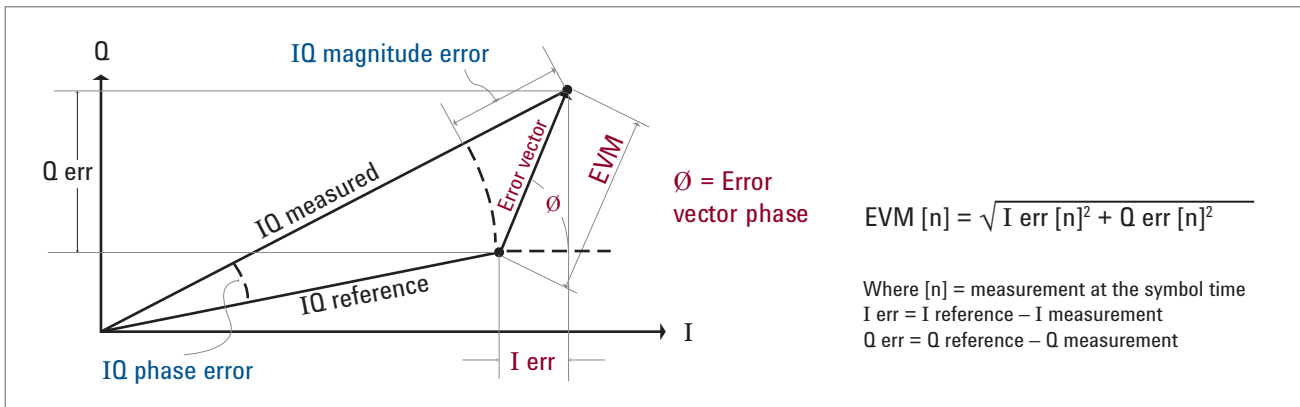

Figure 16.

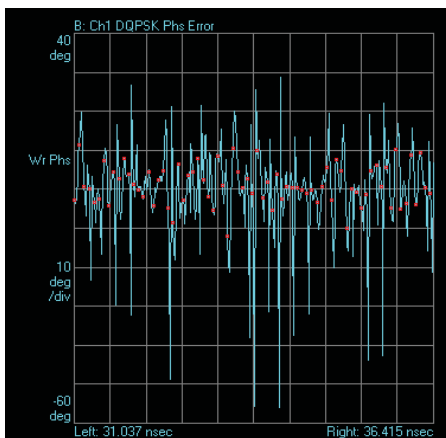

Figure 17.

## Phase error analysis

The concept of error vector analysis is a very powerful tool, offering more than just EVM, it provides the magnitude and the phase error (Figure 15) for each symbol or sample. The phase error is displayed for each sample point and each constellation point in the same diagram, showing what happens during the transition.

This information gives an indication about the shape of phase error. It can be a repetitive or a random-like shape, which can give a valuable indication about the source of the phase error, like in jitter analysis.

# Spectral Analysis and Transmitter Laser Characterization

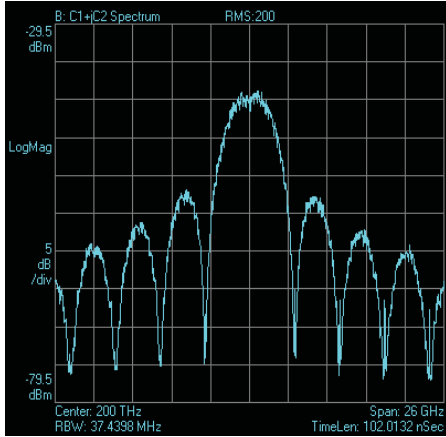

Figure 18.

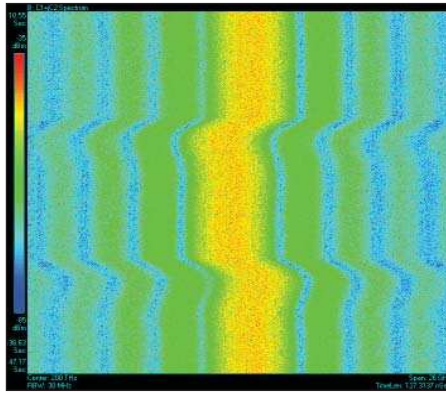

Figure 19.

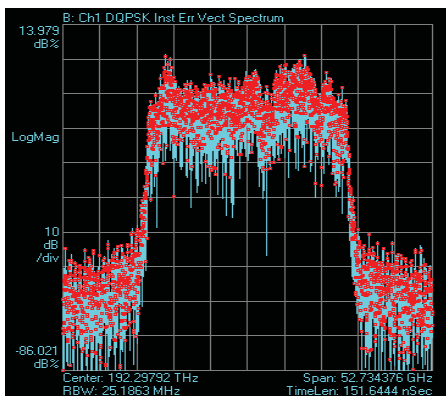

Figure 20.

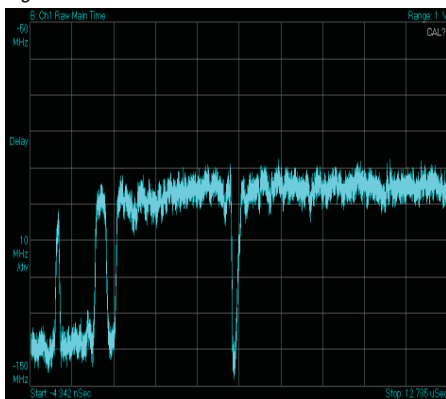

Figure 21.

## Narrow-band, high-resolution spectrum

The narrow-band high resolution spectrum displays the Fourier-transformed spectrum of the time-domain signal. The center-frequency corresponds to the local oscillator frequency, as entered in the user interface.

This tool gives a quick overview of the spectrum of the analyzed signal and the resulting requirements on channel width in the transmission system. The spectrogram shows the evolution of the spectrum over time, offering the option to monitor drifts of the carrier laser (see Figure 17).

## Spectrogram

A spectrogram display provides another method of looking at trace data. In a spectrogram display, amplitude values are encoded into color. For the Spectrum Analyzer application, each horizontal line in the spectrogram represents a single acquisition record.

By observing the evolution of the spectrum over time, it is possible to detect sporadic events that normally would not be visible as they occur only during one or two screen updates.

In addition, it is possible to so detect long-term drifts of a transmitter laser or even detect periodic structures in the spectrogram of a laser spectrum.

## Error vector spectrum

The EVM spectrum measurement is calculated by taking the FFT of the EVM versus time trace. Any periodic components in the error trace will show up as a single line in the error vector spectrum. Using this tool to analyze the detected signal offers the possibility to detect spurs that are overlaid by the normal spectrum.

Therefore spurs that are not visible in the normal signal spectrum can be detected. This helps to create best signal quality of a transmitter or to detect hard to find problems in a transmission system.

## Laser line-width measurement

In optical coherent transmission systems operating with advanced optical modulation formats, the performance of the transmitter signal and therefore the available system penalty depends strongly on the stability of the transmitter laser. The spectral analysis tools can also display the frequency deviation of an unmodulated transmitter laser over a measured time period. In Figure 20, the frequency deviation of a DFB laser is displayed on the Y-axis and the x-axis is scaled in measured time.

This gives an excellent insight into the time-resolved frequency stability of a laser and helps in detecting error causing mode-hops.

# Generic APSK Decoder

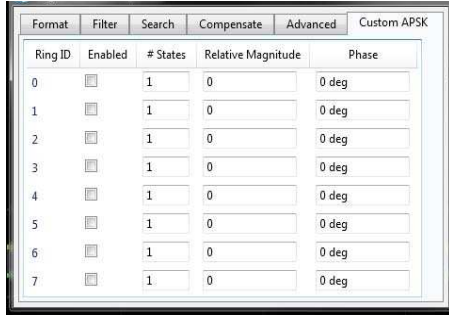

Ring ID	Enabled	# States	Relative Magnitude	Phase
0	<input type="checkbox"/>	1	0	0 deg
1	<input type="checkbox"/>	1	0	0 deg
2	<input type="checkbox"/>	1	0	0 deg
3	<input type="checkbox"/>	1	0	0 deg
4	<input type="checkbox"/>	1	0	0 deg
5	<input type="checkbox"/>	1	0	0 deg
6	<input type="checkbox"/>	1	0	0 deg
7	<input type="checkbox"/>	1	0	0 deg

Figure 22.

## Customer configurable APSK decoder

This new generic decoder allows the user to configure a custom decoding scheme in accordance with the applied IQ signal.

Up to 8 amplitude levels can be combined freely with up to 256 phase levels. This provides nearly unlimited freedom in research to define and evaluate the transmission behavior of a proprietary modulation format.

The setup is easy and straightforward. Some examples are shown below.

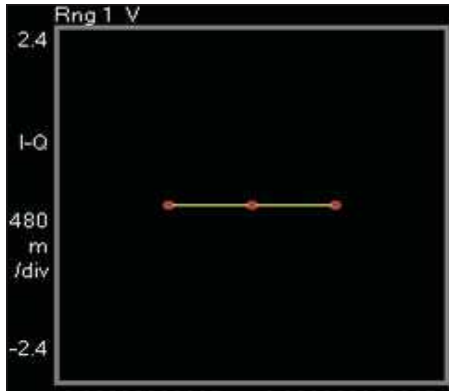

Figure 23.

## Optical duobinary decoder

In 40G transmission systems, an optical duobinary format is often used. In order to test the physical layer signal at the transmitter output or along a link, the analysis software now supports this commonly used optical format. A predefined setting that has a preconfigured optical duo binary decoder is part of the instrument and the analysis software.

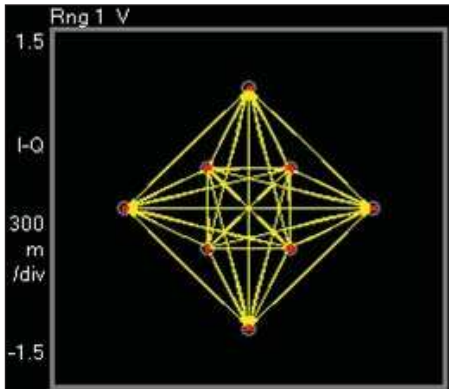

Figure 24.

## Optical 8 QAM decoder

This example of a coding scheme can code 3 bits per symbol with a maximum distance between the constellation points, providing a good signal to noise ratio.

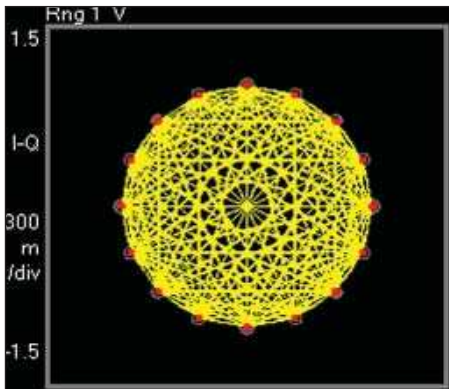

Figure 25.

## Optical 16 PSK decoder

This is another example of a more complex pure phase modulated optical signal that is sometimes used in research.

With the custom-defined APSK decoder, the same analysis tools are available as in the predefined decoders.



# N4391A Block Diagram

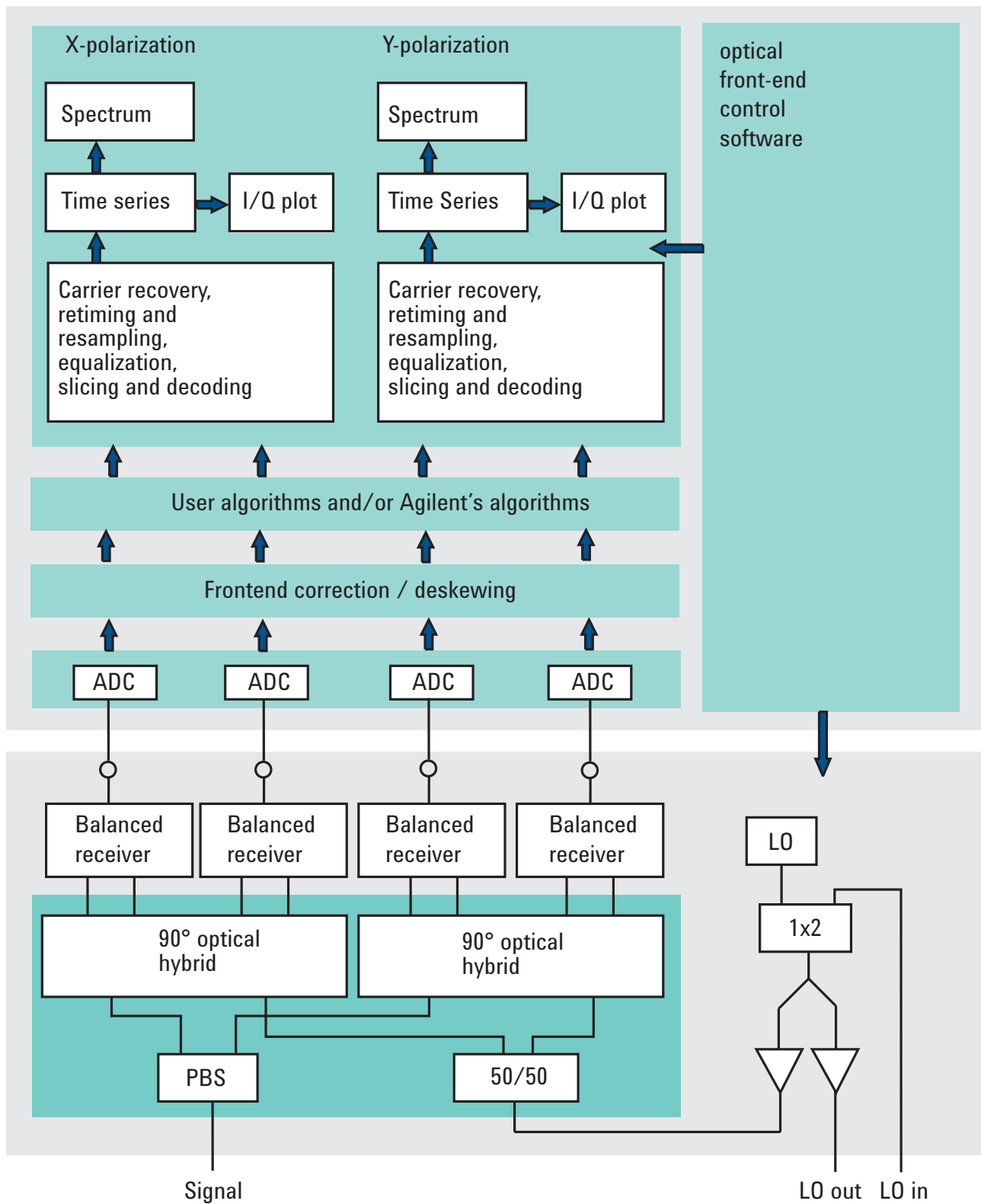

Figure 30. Block diagram of the optical modulation analyzer.

## The Infiniium 90000 Q-Series Oscilloscope for N4391A

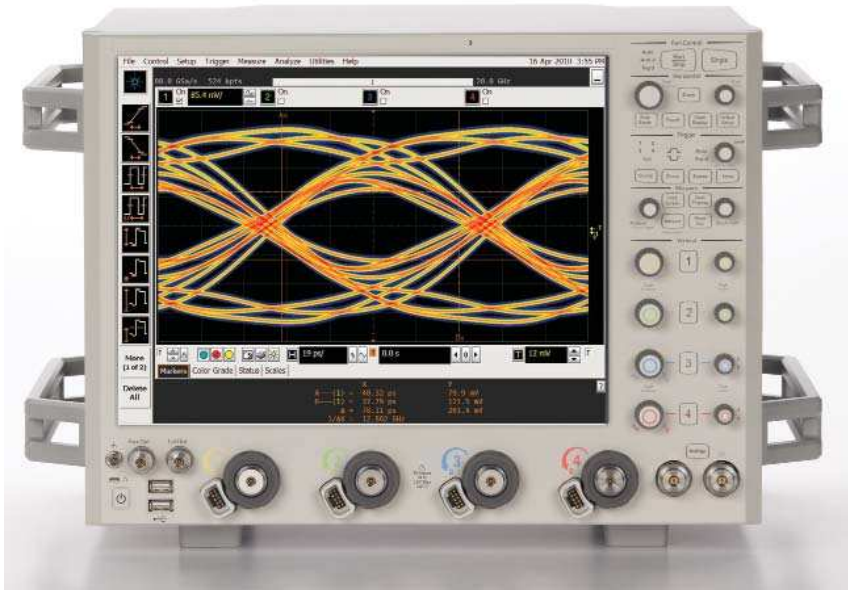

Figure 31. The Infiniium 90000 Q-Series oscilloscope.

**At the extremes of electrical and optical measurements, the right oscilloscope will help you explore the “what” and understand the why.”**

That’s the idea behind Q-Series oscilloscopes, our latest step forward in the application of Agilent’s microwave expertise to real-time oscilloscopes. With industry-leading bandwidths, the Q-Series lets you see your fastest signals as they really are. Equip your lab with Q-Series scopes—and achieve your real edge.

### Specifications

- 33 GHz analog bandwidth
- 2 channel sample rate: 160 GSa/s
- 4 channel sample rate: 80 GSa/s
- 2 Gpts of memory
- > 20 GHz edge trigger bandwidth
- 30 GHz probing system

### Features and benefits

- Up to 33 GHz true analog bandwidth on four channels
- Up to 120 Gbaud symbol rate analysis
- Four times better EVM noise floor than typical QPSK transmitter
- Compact four channels in turn-key solution
- 4 x 80-Gs real-time sampling for optimal phase tracking
- Well-defined interface to include your own MATLAB algorithms
- Customer-configurable APSK and OFDM decoders

## The Infiniium 90000 Q-Series Oscilloscope for N4391A (continued)

### Using in next generation optical communications research

Q-Series oscilloscopes are also available in combination with the N4391A optical modulation analyzer as a fully specified turn-key instrument. This compact solution offers the highest bandwidth available on the market and is the most advanced test solution for advanced research on 400G and terabit transmission.

Even for the lower 20 GHz bandwidth range, this compact and easy-to-use solution is a reference system for 100G transmission required by R&D labs working at 100G and beyond.

By providing four channels of 33 GHz bandwidth, the Q-Series saves you the expense of a second instrument to analyze dual polarization.

If you prefer to operate with your own optical receivers but want to benefit from the enormous analysis capability, you can get the N4391A's analysis software as a standalone package.

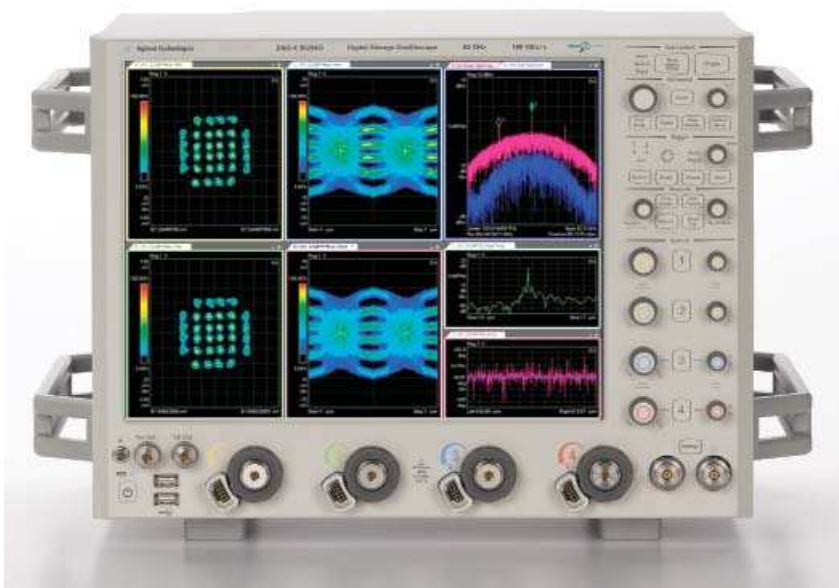

Figure 32. The N4391A offers a powerful toolset to debug the most challenging errors, with tools proven by thousands of RF engineers.

### Configuring systems with high channel counts

Two oscilloscope ADC channels are required to measure the I and Q vector components of a single coherent optical channel. Capacity of systems can be further increased by modulating orthogonal polarizations and/or multiple core fibers.

For each additional effective carrier, another pair of oscilloscope channels is required. The Agilent 90000 Q-Series can be configured with four channels, each with 33 GHz of bandwidth.

For applications requiring wider bandwidths, over 60 GHz can be achieved in two channels. To increase the channel count or to create more than two channels with over 60 GHz of bandwidth, it is possible to gang together multiple oscilloscopes. Through tying together each oscilloscope on a common 10 MHz reference, the overall system can be synchronized with a channel-to-channel timing uncertainty less than 200 fs.

## The Infiniium 90000 Q-Series Oscilloscope for N4391A (continued)

At the extremes of electrical and optical measurements

**You need to make rise time measurements without being limited by scope bandwidth:**

The Q-Series is Agilent's first oscilloscope to use RealEdge technology, which allows for an industry-leading 63 GHz of bandwidth on two channels. RealEdge technology uses custom chips to seamlessly increase the bandwidth of Q-Series oscilloscopes.

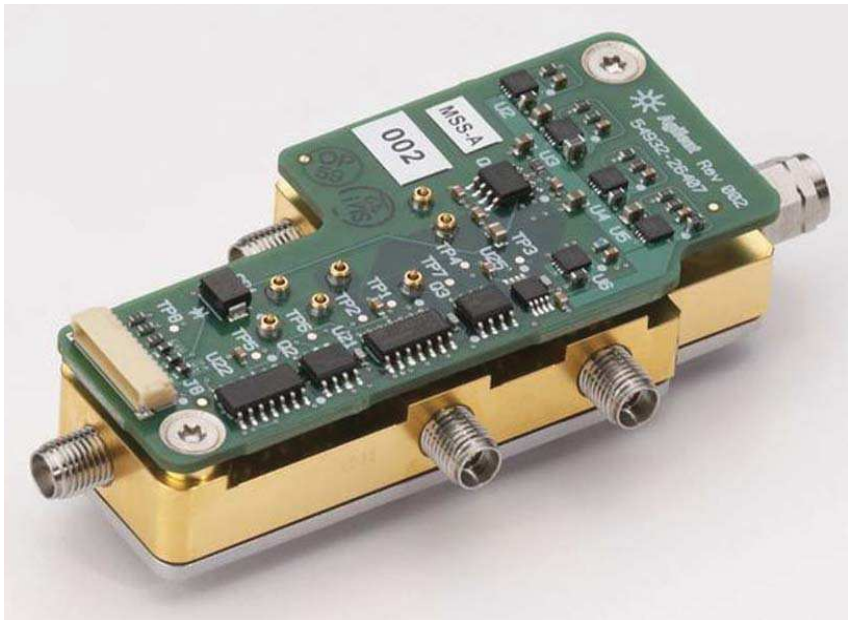

Figure 33. Infiniium's new RealEdge technology blocks enable 63 GHz real-time bandwidth.

**You need to see your signal and not your measurement system:**

Using Agilent's proprietary indium phosphide technology the N2806A PrecisionProbe Advanced creates a signal edge that is an incredible 5 ps (20/80), which the Q-Series is capable of measuring.

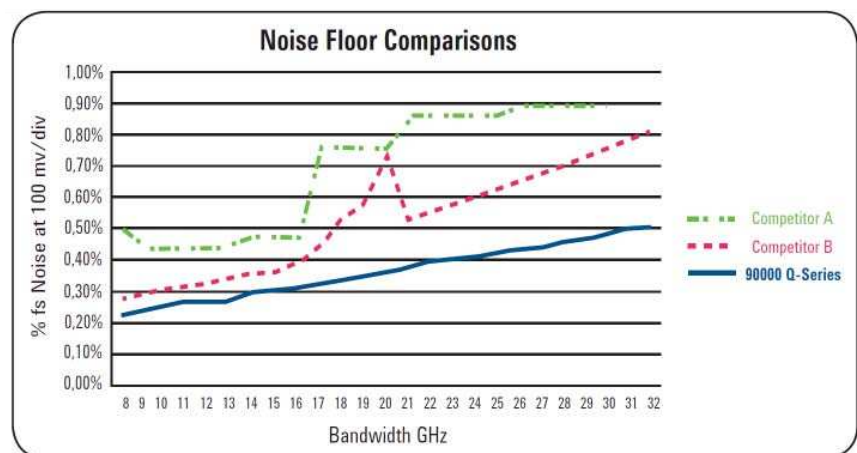

Figure 34. The 90000 Q-Series features the industry's lowest noise floor (noise as a percentage of full scale display).

## The Infiniium 90000 Q-Series Oscilloscope for N4391A (continued)

### You need to see your signal and not oscilloscope noise:

The Q-Series leverages technology from the award-winning Infiniium 90000 X-Series oscilloscope, which provides leading signal integrity specifications. The Q-Series takes advantage of leading-edge indium phosphide chip technology and custom thin film packaging technology, which ultimately leads to the lowest-noise real-time oscilloscope in the world. With industry-leading bandwidths, Q-Series scopes let you see your fastest signals as they really are.

Figure 35. Infiniium's custom multichip modules feature indium phosphide chips and Agilent proprietary packaging technology, enabling high bandwidth and low noise.

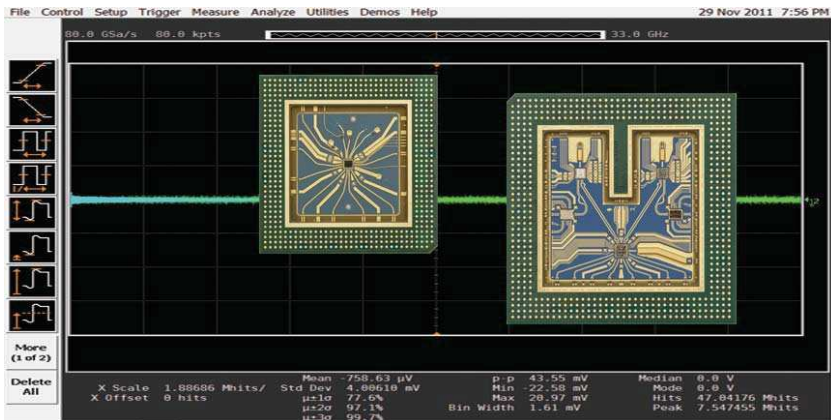

# Definitions

Generally, all specifications are valid at the stated operating and measurement conditions and settings, with uninterrupted line voltage.

## **Specifications (guaranteed)**

Describes warranted product performance that is valid under the specified conditions. Specifications include guard bands to account for the expected statistical performance distribution, measurement uncertainties changes in performance due to environmental changes and aging of components.

## **Typical values (characteristics)**

Characteristics describe the product performance that is usually met but not guaranteed. Typical values are based on data from a representative set of instruments.

## **General characteristics**

Give additional information for using the instrument. These are general descriptive terms that do not imply a level of performance.

## Digital demodulation measurement conditions

- Data acquisition: DSA 91304A series and DSOX 90000 Q series
- Office environment
- Signal power +7.5 dBm
- Scope range 20 mV/div
- I-Q bandwidth 12.5 GHz
- (D)QPSK demodulation
- Single polarization aligned; carrier, phase linearization algorithm
- 500 symbols per analysis record

## General Characteristics

Dimensions (Wide x Tall x Deep)		
Q series based N4391A system		51 cm (20.0") x 47cm (18.5") x 52 cm (20.5")
DSOX9xx04Q oscilloscope		51 cm (20.0") x 34 cm (13.3") x 49 cm (19.4")
Optical receiver		48 cm (18.9") x 13 cm (5.2") x 49 cm (19.4")
Packaged dimensions		
DSOX9xx04Q		69 cm x 48 cm x 81 cm
Optical receiver		65 cm x 49 cm x 79 cm
Weight		
Product net weight	DSOX9xx04Q	32 kg (71 lbs)
	DSA 91304	20 kg (44 lbs)
	DSOX9xx04Q-N4391A-System	48 kg (106 lbs)
Packaged product		60 kg (132 lbs)
Power requirements		
100 to 240 V~, 50 to 60 Hz		
Optical receiver		Max. 300 VA
Storage temperature range		
-40° C to +70° C		
Operating temperature range		
+5° C to +35° C		
Humidity		
15% to 80% relative humidity, non-condensing		
Altitude (operating)		
0 ... 2000 m		
Recommended re-calibration period		
1 year		
Shipping contents		
1x Optical coherent receiver N4391A 1 to		
3x FC/APC connector interface (quantity depends on options ordered) 81000NI		
1x Language labels sheet 81645- 44309		
1x Torque wrench, 8lb- in, 5/16 inch 8710- 1765		
1x Wrench, open- end, 8 mm, steel hard chrome finish 8710- 2466		
1x Calibration certificate 9230- 0333		
1x Wrist strap with cord 6- lg blue 9300- 1405		
1x China RoHS addendum for photonic test and measurement products (9320- 6654)		
1x UK6 report E5525- 10285		
1x Getting started guide for the N4391A N4391- 90A01		
1x Power cord (country dependent)		

## General Characteristics (continued)

### Contents for data acquisition

1x Scope including all standard accessories
1x Optical mouse, USB/PS2 1150- 7799
1x 104 key standard keyboard with USB connector 1150- 7896
1x Stylus- pen, cushion grip 1150- 7997 1x cable, calibration 54916- 61626
1x Cable- assembly USB- Plug A TO B 4-COND 500 mm 8121- 1695
1x Connector saver collars kit of 10 54916- 60003
1x Connector assembly- 3.5 mm female to female- kit of 5 54916- 68717
1x Quick start guide (English) 54932- 92000
1x Software/firmware addendum 5190- 1894
1x China RoHS addendum for oscilloscope 9320- 6678
8x Screw, pan- head
1x Torx-T15, M3.5X0.6 8 mm-long 0515- 1402 3x 90- deg- flat- head
1xTorx-T10, M3X0.5 10 mm- long 0515- 2033
1x Plate scope interface N4391- 04106
1x Adapter plate for scope type B N4391- 04108
1x Bracket rear for scope type B N4391- 04109 2x bracket rear N4391- 25073
1x RF cable kit for single scope setup type B (content see below) N4391- 61663

### Coherent receiver optical input

DUT input	+ 20 dBm max
	9 $\mu$ m single-mode angled
	81000 connector interfaces
LO input	+ 20 dBm
	9 $\mu$ m PMF angled
	81000 connector interfaces
LO output	+ 20 dBm max
	9 $\mu$ m PMF angled
	81000 connector interfaces

### Laser safety information

All laser sources listed above are classified as Class 1M according to IEC 60825-1/2007.

All laser sources comply with 21 CFR 1040.10 except for deviations pursuant to Laser Notice No. 50, dated 2007-06-24.



# Specifications

**Table 1. Typical specifications, if not specified otherwise.**

Optical modulation analyzer		
Description		
Maximum detectable baud rate		Up to 62 Gbaud
Sample rate		4 x 80 Gs/s
Number of polarization alignment algorithms		6
Digital demodulation uncertainty		
Error vector magnitude noise floor		1.8 %rms
Amplitude error		1.1 %rms
Phase error		0.9°
Quadrature error		0.05°
Gain imbalance between I and Q		< 0.007 dB
Image suppression		> 35 dB
S/N		> 60 dB
Sensitivity		-20 dBm
Supported modulation formats <sup>1</sup>		
BPSK, 8BPSK, VSB -8, -16,	FSK 2-, 4-, 8, 16 level	EDGE
Offset QPSK, QPSK, Pi/4 QPSK	DQPSK, D8PSK	DVB QAM 16, 32, 64, 128, 256
QAM 16-, 32-, 64-, 128-, 256-, 512-, 1028-	MSK type 1, type 2 CPM (FM)	APSK 16/32 (12/4 QAM)
StarQAM -16, -32	Generic APSK decoder	

1. For Light version only BPSK, DP-BPSK, DPSK, DP-DPSK, QPSK, DP-QPSK are supported.

## Specifications (continued)

**Table 2. Typical specifications, if not specified otherwise.**

Coherent reference receiver		
Description		
<b>Optical DUT input</b>		
Optical input wavelength range		1528 nm to 1630 nm
Maximum input power		+14 dBm
Maximum input power, damage level		+20 dBm
Receiver polarization extinction ratio		> 40 dB
Average input power monitor accuracy		±0.5 dB
<b>Optical local oscillator output</b>		
Optical CW output power <sup>1</sup>		> +14 dBm
Wavelength range		1528 nm to 1630 nm
<b>External local oscillator input</b>		
Optical input wavelength range		1528 nm to 1630 nm
External local oscillator input power range		0 dBm to +14 dBm
Maximum input peak power (damage level)		+20 dBm
Small signal gain, external laser input to local oscillator output (-20 dBm LO input power)		28 dB @ 1550 nm
Saturation output power @ -3 dB compression		15 dBm
<b>Other</b>		
Electrical bandwidth	Standard version	43 GHz, 37 GHz guaranteed
	Light version (software upgradable)	22 GHz
Optical phase angle of I-Q mixer after correction (1529 nm to 1630 nm)		90° ± 0.5°
Relative skew after correction (1529 nm to 1630 nm)		±1 ps

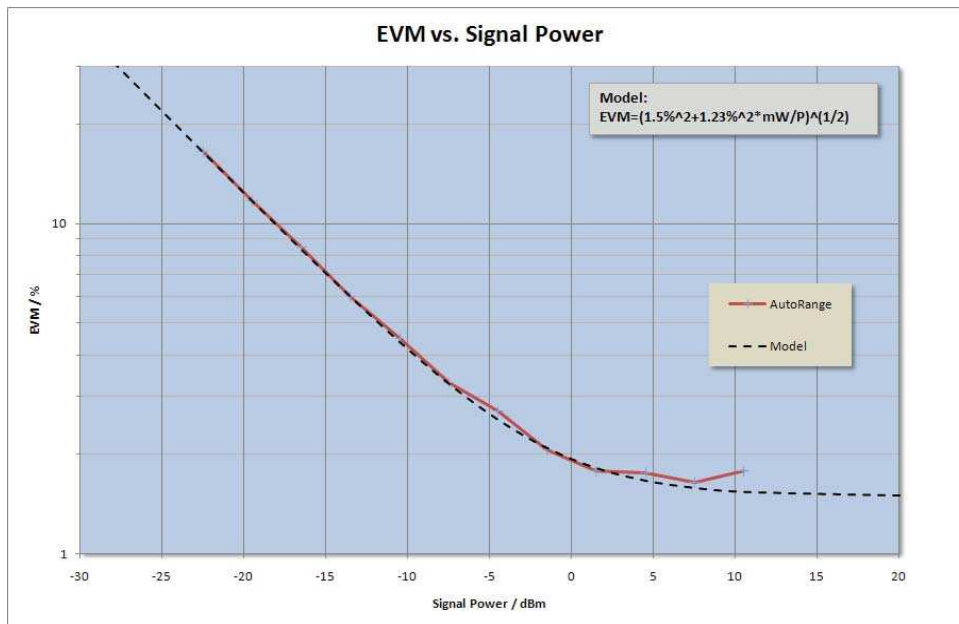

Figure 36. EVM %rms depend on average optical input power.

This diagram shows the %rms Error Vector Magnitude (EVM) normalized to the highest error vector within an analysis record of 500 symbols as a function of signal input power. The EVM %rms level at higher power levels results from the instrument noise level. The increase at lower signal power levels is a result of decreasing signal to noise ratio. The fitted model reveals the EVM %rms noise floor in the offset term.

## Specifications (continued)

**Table 3. Typical specifications, if not specified otherwise.**

Data acquisition (For Agilent 90000-X and 90000-Q series Oscilloscopes)		
Description		
Sample rate	Up to 80 GSa/s on each channel	
Data acquisition bandwidth	16/20/25/32 GHz upgradable	
Jitter between channels	Typ 700 fs	
Noise	0.6 mV rms @ 10 mV range, 32 GHz bw	
ADC resolution	8 bit/16 bit (interpolated)	
Sample memory per channel	Up to 2 Gs/channel	
Local oscillator (Guaranteed specification if not mentioned otherwise)		
Description	Option -500, 501	Option -510
Wavelength range	Option 500	1527.6 to 1565.5 nm (196.25 to 191.50 THz)
	Option 501	1570.0 to 1608.8 nm (190.95 to 186.35 THz)
Minimum wavelength step	25 GHz	1 pm
Tuning time/sweep speed	< 30 s	50 nm/s
Absolute wavelength accuracy	± 22 pm	± 20 pm, ± 5 pm typical
Stability (short term)	100 kHz	100 kHz
Sidemode suppression ratio	50 dB typical	≥ 50 dB
RIN	-145 dB/Hz (10 MHz to 40 GHz) typical	-145 dB/Hz (0.1 to 6 GHz) typical
High resolution spectrometer		
Description		
Maximum frequency span	31.25/40/50/62.5 GHz	
LO wavelength range	1528 nm to 1630 nm	
Image suppression	> 35 dB	
Number of FFT points	409601	
Minimum RBW (record length 10 <sup>6</sup> points)	4 kHz	
Signal to noise ratio	60 dB@ 7.5 dBm signal input power	
Frequency accuracy	Absolute	± 5 pm

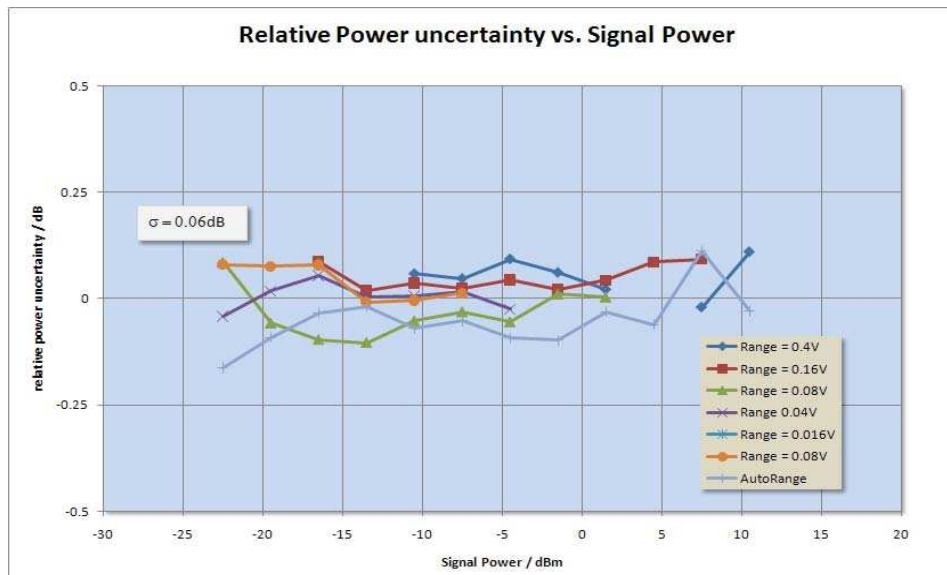

Figure 37. Relative power uncertainty of N4391A<sup>1</sup> with internal local oscillator @ 1550 nm.

## Specifications (continued)

**Table 4. Analysis tools.**

Measurement display and analysis tools		
Description	Standard N4391A	N4391A light version
Constellation diagram	Yes	Yes
I-Q diagram	Yes	Yes
Eye diagram for I and Q signal	Yes	Yes
Error vector magnitude	Yes	Yes
Spectrum	Yes	Yes
Spectrogram	Yes	Yes
Spectral analysis tools	Yes	Yes
Error vector spectrum	Yes	Yes
Detected bits	Yes	Yes
Phase error	Yes	Yes
Amplitude error	Yes	Yes
Raw data vs time	Yes	Yes
Phase vs time	Yes	Yes
Group delay	Yes	Yes
Frequency offset	Yes	Yes
Quadrature error	Yes	Yes
IQ offset	Yes	Yes
IQ gain imbalance	Yes	Yes
Adaptive equalizer	Yes	Yes
Selectable phase tracking bandwidth	Yes	Yes
Reference signal from detected symbols	Yes	Yes
Symbol polarization on poincare sphere	Yes	No
Raw data replay with different parameter setting	Yes	No
Raw data display	Yes	Yes
Result export formats	Matlab (Version 4, 5), csv, txt, sdf, sdf fast	Matlab (Version 4, 5), csv, txt
Adaptive equalization	Yes	Yes
Bit error ratio measurements	Number of counted bits/symbols	Number of counted bits/symbols
	Numbers of errors detected	Numbers of errors detected
	Bit error ratio	Bit error ratio
	Stop acquisition on detected error	Stop acquisition on detected error
CD PMD compensation and measurement	Yes	No
Configurable APSK decoder	Yes	No
Coupled markers over different displays	Yes	Yes
Macro programming with VBA and C#	Yes	No
Block mode (analysis of > 4096 symbols in one concatenated block)	Yes	No
Trigger support for loop test	Yes	No
User algorithm in data processing	Yes, unlimited number of algorithms	Limited to one algorithm
Available number of algorithm	6	6

# Mechanical Outlines for 90000-Q Series Data Acquisition (Dimensions in mm)

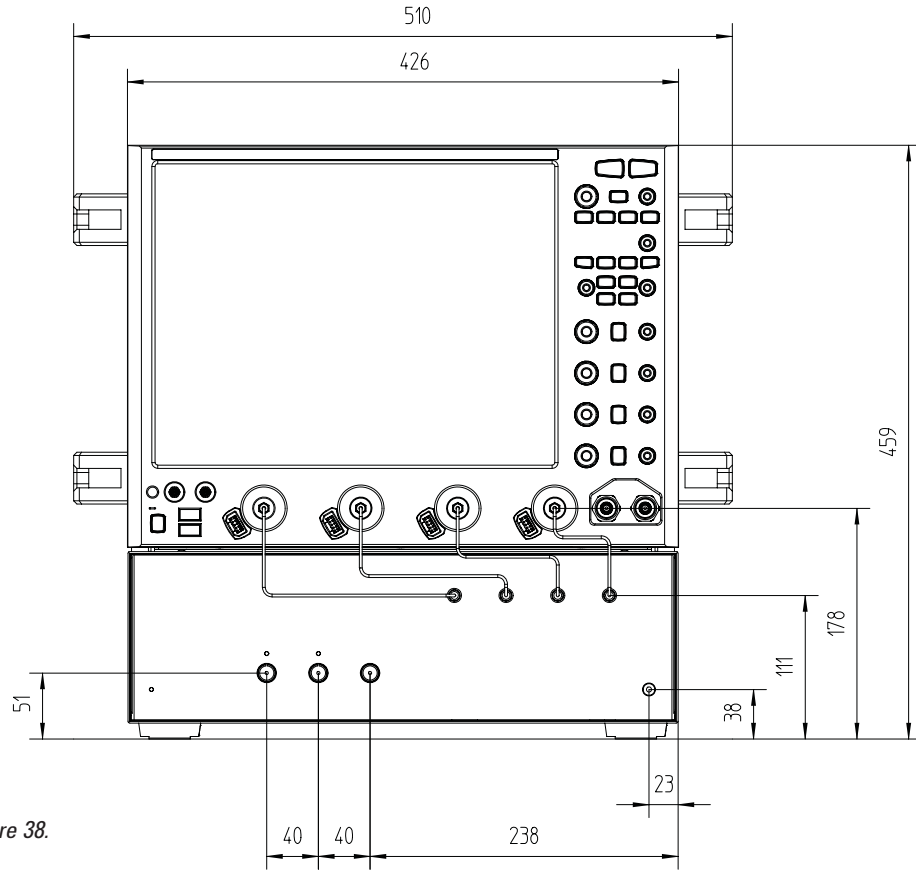

Figure 38.

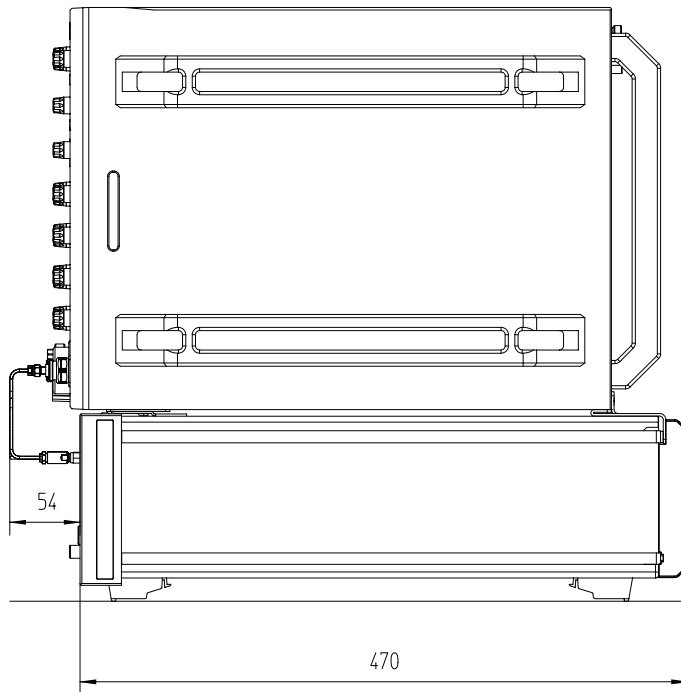

Figure 39.

# Hardware Options Description

Table 4 provides a description and a block diagram of the available hardware configurations. In addition a selection of tree types of local oscillators are offered.

Product number	Hardware configuration description
----------------	------------------------------------

*Optical modulation analyzer with 4 channel receiver and analysis software.*  
 This option is the core hardware with analysis software and has always to be ordered.

Figure 40. N4391A-110

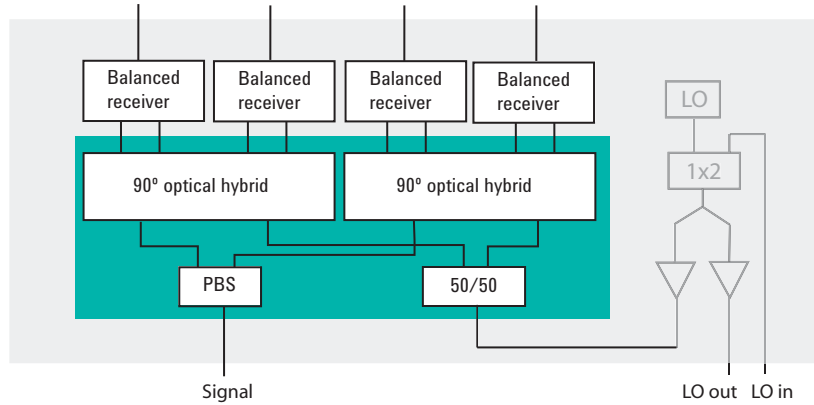

*Internal Local Oscillator.*  
 For the internal local oscillator a selection of 3 types of laser is provided. C or L band iTLA with slow tuning speed or fast 50 nm/s tuning C & L band laser. Select the laser type with option block 5xx

Figure 41. N4391A-210

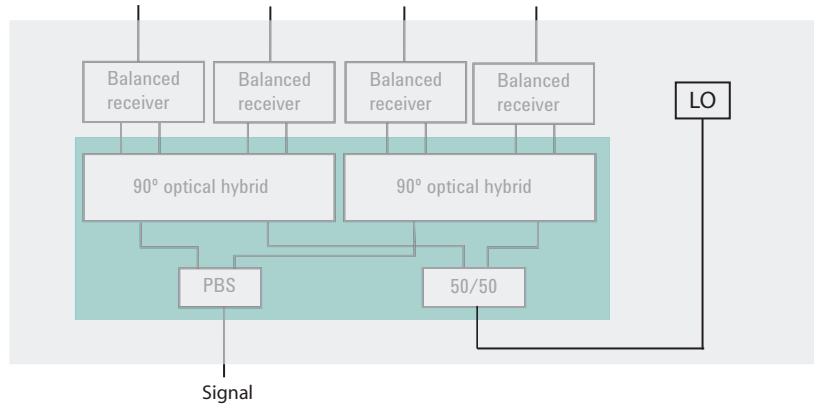

*Internal Local Oscillator and External Local Oscillator Input and Local Oscillator.*  
 For the internal local oscillator a selection of 3 types of laser is provided. C or L band iTLA with slow tuning or 50 nm/s tuning C & L band laser. Select the laser type with option block 5xx. In addition a semiconductor amplified output of the local oscillator signal is provided at the instrument's output and an external local oscillator signal can be feed into the receiver for homodyne test setups.

Figure 42. N4391A-220

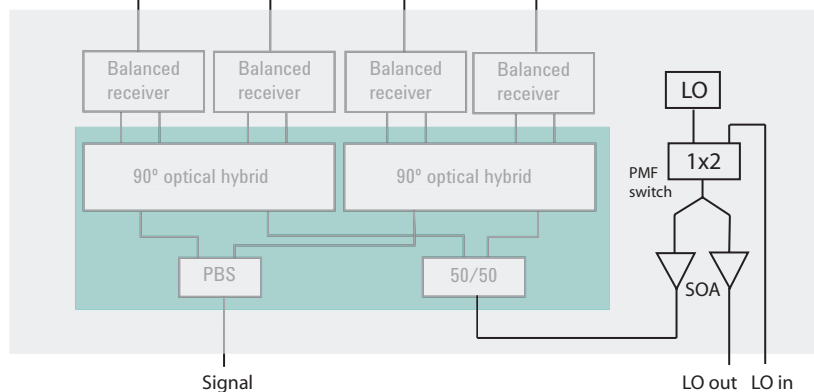

## Ordering Information

**Table 5. Configuration and ordering information**

<b>Optical modulation analyzer</b>	
Model number	Receiver options
N4391A -110	Optical modulation analyzer with 4 channel receiver and analysis software
<b>Local oscillator options</b>	
N4391A -210	Internal local oscillator
N4391A -220	Internal local oscillator and external local oscillator input and local oscillator output
<b>Local oscillator, tunable laser options</b>	
N4391A-500	C band iTLA internal local oscillator
N4391A-501	L band iTLA internal local oscillator
N4391A-510	Fast tunable C & L band local oscillator
<b>Software analysis licenses</b>	
N4391A-420	User configurable OFDM decoder
<b>Data acquisition</b>	
N4391A-300	Data acquisition with 20 Ms per channel memory (DSA91304)
N4391A-320	Infiniium oscilloscope 20 GHz 80 GSa/s 2 Ch, 20Ms/Ch memory (1x DSOX92004A)
N4391A-321	Infiniium oscilloscope 25 GHz 80 GSa/s 2 Ch, 20Ms/Ch memory (1x DSOX92504A)
N4391A-322	Infiniium oscilloscope 32 GHz 80 GSa/s 2 Ch, 20Ms/Ch memory (1x DSOX93204A)
N4391A-Q20	Infiniium oscilloscope 20 GHz 80 GSa/s 4 Ch, 20Ms/Ch memory (1x DSOX92004Q)
N4391A-Q25	Infiniium oscilloscope 25 GHz 80 GSa/s 4 Ch, 20Ms/Ch memory (1x DSOX92504Q)
N4391A-Q33	Infiniium oscilloscope 33 GHz 80 GSa/s 4 Ch, 20Ms/Ch memory (1x DSOX93304Q)
<b>Oscilloscope integration</b>	
N4391A-M00	Integration of Agilent 90000 oscilloscope (up to 4x13 GHz)
N4391A-M01	Integration of Agilent 90000-X oscilloscope (up to 4x16 or 2x32 GHz)
N4391A-M33	Integration of one customer owned 90000 Q series oscilloscope with new N4391A optical receiver with up to 4x33 GHz
<b>Light version</b>	
N4391A-CONF01	Consists of -110 (bandwidth 22 GHz limited), -210, -500, Mxx as fixed configuration
N4391A-CONF11	SW upgrade to full feature set and up to 33 GHz system bandwidth
<b>Hardware upgrade options</b>	
N4391AU-M01	Integration of customer owned single 90000-X Series infiniium oscilloscope with customers N4391A optical receiver
N4391AU-M02	Upgrade from single to dual 90000-X oscilloscope
N4391AU-E02	Upgrade N4391A Option 210 to Option 220
N4391AU-M33	Upgrade of customer owned N4391A testset with customer owned infiniium oscilloscope 20, 25, or 33 GHz 80 GSa/s 4 Ch (1x DSOX9xx04Q)
<b>Stand alone software licenses</b>	
N4391AU-450	Optical modulation analyzer analysis software license (stand alone)
N4391AU-451	Optical modulation analyzer hardware connection license for -450
<b>Trainings</b>	
PS-S20	1 day startup training (highly recommended)

## N4391A Related Literature

**Table 6. Agilent publications**

Publication title	Publication number
N4391A Optical Modulation Analyzer Data Sheet	5990-3509EN
Metrology of Optical Advanced Modulation Formats, White Paper	5990-3748EN
Kalman Filter Based Estimation and Demodulation of Complex Signals, White paper	5990-6409EN
<hr/>	
Webinar: " <a href="#"><i>Coherent Detection of Polarization Multiplexed Amplitude and Phase Modulated Optical Signals</i></a> "	
Webinar: " <a href="#"><i>Rating optical signal quality using constellation diagrams</i></a> "	
Webinar: " <a href="#"><i>Test and measurement challenges as we approach the terabit era</i></a> "	
89600 Series Vector Signal Analysis Software 89601A/89601AN/89601N12 Technical Overview	5989-1679EN
AN 150-15: Vector Signal Analysis Basics Application Note	5989-1121EN
AN 1298: Digital Modulation in Communication Systems - An Introduction, Application Note	5965-7160E
Infiniium DSO/DSA 90000-Q Series Real-Time Oscilloscope Data Sheet	5990-9712EN



**myAgilent**

[www.agilent.com/find/myagilent](http://www.agilent.com/find/myagilent)

A personalized view into the information most relevant to you.



[www.axiestandard.org](http://www.axiestandard.org)

AdvancedTCA® Extensions for Instrumentation and Test (AXIe) is an open standard that extends the AdvancedTCA for general purpose and semiconductor test. Agilent is a founding member of the AXIe consortium.



[www.lxistandard.org](http://www.lxistandard.org)

LAN eXtensions for Instruments puts the power of Ethernet and the Web inside your test systems. Agilent is a founding member of the LXI consortium.



[www.pxisa.org](http://www.pxisa.org)

PCI eXtensions for Instrumentation (PXI) modular instrumentation delivers a rugged, PC-based high-performance measurement and automation system.

### Agilent Channel Partners

[www.agilent.com/find/channelpartners](http://www.agilent.com/find/channelpartners)

Get the best of both worlds: Agilent's measurement expertise and product breadth, combined with channel partner convenience.



Agilent Advantage Services is committed to your success throughout your equipment's lifetime. To keep you competitive, we continually invest in tools and processes that speed up calibration and repair and reduce your cost of ownership. You can also use Infoline Web Services to manage equipment and services more effectively. By sharing our measurement and service expertise, we help you create the products that change our world.

[www.agilent.com/find/advantageservices](http://www.agilent.com/find/advantageservices)



[www.agilent.com/quality](http://www.agilent.com/quality)

[www.agilent.com](http://www.agilent.com)  
[www.agilent.com/find/oma](http://www.agilent.com/find/oma)

For more information on Agilent Technologies' products, applications or services, please contact your local Agilent office. The complete list is available at:

[www.agilent.com/find/contactus](http://www.agilent.com/find/contactus)

### Americas

Canada	(877) 894 4414
Brazil	(11) 4197 3600
Mexico	01800 5064 800
United States	(800) 829 4444

### Asia Pacific

Australia	1 800 629 485
China	800 810 0189
Hong Kong	800 938 693
India	1 800 112 929
Japan	0120 (421) 345
Korea	080 769 0800
Malaysia	1 800 888 848
Singapore	1 800 375 8100
Taiwan	0800 047 866
Other AP Countries	(65) 375 8100

### Europe & Middle East

Belgium	32 (0) 2 404 93 40
Denmark	45 45 80 12 15
Finland	358 (0) 10 855 2100
France	0825 010 700*
	*0.125 €/minute
Germany	49 (0) 7031 464 6333
Ireland	1890 924 204
Israel	972-3-9288-504/544
Italy	39 02 92 60 8484
Netherlands	31 (0) 20 547 2111
Spain	34 (91) 631 3300
Sweden	0200-88 22 55
United Kingdom	44 (0) 118 927 6201

For other unlisted countries:

[www.agilent.com/find/contactus](http://www.agilent.com/find/contactus)

Revised: October 11, 2012

Product specifications and descriptions in this document subject to change without notice.

© Agilent Technologies, Inc. 2012  
Published in USA, November 21, 2012  
5990-3509EN



**Agilent Technologies**