

# N5412B Serial Attached SCSI-2 (SAS-2) Compliance Test Software for Infiniium 90000 Series Oscilloscopes

## Data Sheet

### N5421A SAS IT/IR Test Fixtures for SFF-8482 SAS x2 Internal Plug/Receptacle Interfaces

#### Features

The N5412B SAS-2 electrical test software simplifies the validation of SAS designs:

- Test definitions based on UNH-IOL standard SAS 2.1 specification
- Support SAS 1.5 Gbps and 3.0 Gbps and 6.0 Gbps data rate
- Easily select tests and configure SAS IT/CT interfaces for compliance testing
- Automated setup and programming of scope measurements
- Graphical HTML test results report format for documentation and sharing
- Trials test reporting capability to allow quick comparison of test results with multiple test patterns or device configurations (TX drive strength, pre-emphasis ratios, slew rates, etc.)

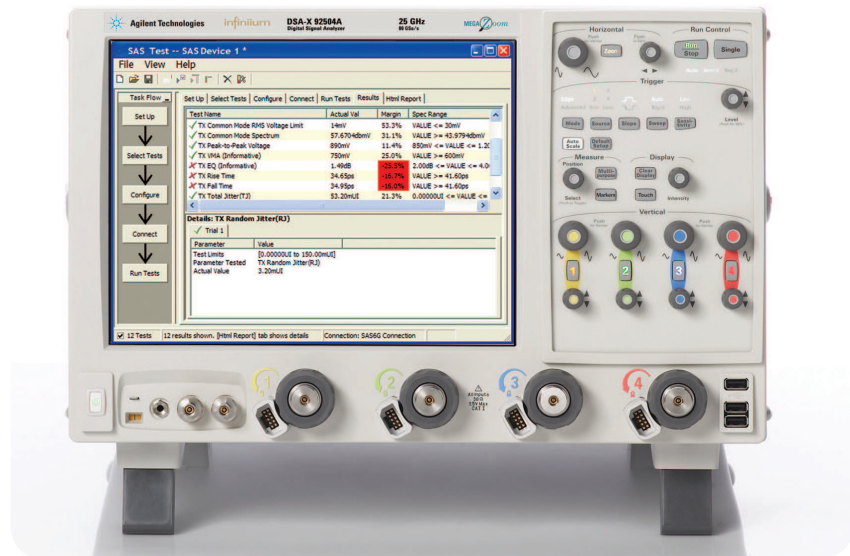

#### Verify and debug your SAS devices faster and more easily

Agilent Technologies' N5412B serial attached SCSI-2 (SAS-2) compliance test software for Infiniium 90000 oscilloscopes provides you with a fast and easy way to validate and debug your SAS 1.5 Gbps, 3.0 Gbps and 6.0 Gbps silicon, host bus adapter, initiator, high-density disk drive or enclosure backplane. It also supports automated SAS out-of-band (OOB) signal tests with the 81134A pattern

generator and N4903B BERT with Option 002. The SAS compliance test software allows you to automatically execute SAS electrical checklist tests at each of the IT and CT interface points and displays the results in a flexible report format. In addition to the measurement data, the report provides a margin analysis that shows how closely your device passed or failed each test.



To make measurements with the N5412B SAS-2 compliance test software, you also will need a method of connecting to the SAS compliance interface on the electrical mating surfaces of your SAS connector.

Agilent currently provides a full set of compliance test fixtures for the SFF-8482, SAS x2 internal drive/backplane connector interfaces for SAS 1.5 Gbps, 3.0 Gbps and 6.0 Gbps. The fixtures do meet the zero-length test load requirement for testing transmitter device compliance point per section 5.7.2 of the SAS-2.1 specification<sup>1</sup>. The N5421A SAS SFF-8482 compliance test fixture kit offers connectivity from the SFF-8482 primary and secondary transmitter and receiver differential ports to SMA for connection to Agilent Infiniium Series ultra-high-performance oscilloscopes. The N5421A kit also includes the necessary TX and RX transient circuit test loads.

The N5412B SAS-2 compliance test software performs a wide range of tests required to meet the physical

layer requirements per section 5.8, Tables 29-43 of the SAS-2.1 specification. The N5412B SAS-2 compliance test software helps you execute the most difficult physical layer tests for transmitters (TX tests only), at the near-end (IT/CT interfaces) of a SAS link, that can be measured with a combination of a 12-GHz or higher real-time oscilloscope and the 81134A programmable pulse/pattern generator. The SCSI Trade Association currently sponsors at least one compliance and interoperability plugfests annually for member companies to test their products' operational capability and margins with other member companies' products.

With the N5412B SAS-2 compliance test software, you can use the same oscilloscope you use for everyday debugging to perform automated testing and margin analysis based on the requirements in the SAS-2.1 specification.

<sup>1</sup> The test circuits and parameters are defined in the "Project TID/2125-D: Serial Attached SCSI-2.1 (SAS-2.1) working draft, Revision 5, July 14, 2010 hereinafter referred to as "the SAS-2.1 specification."

## N5412B saves you time

The N5412B SAS-2 compliance test software saves you time by setting the stage for automatic execution of SAS electrical tests. Part of the difficulty of performing electrical tests for SAS is connecting the oscilloscope to the target device, configuring the scope's measurement system for compliance testing, issuing the proper commands to perform the tests and then analyzing the measured results by comparing them to limits published in the specification. The SAS electrical test software does much of this work for you. In addition, if you discover a problem with your device, debug tools in the scope are available to aid in root-cause analysis.

The N5412B SAS-2 compliance test software offers the required tests to verify compliance with the physical layer parameters defined per section 5.8, Tables 29-43 of the SAS-2.1 specification. The software automatically configures the oscilloscope for each test, and it provides an informative results report that includes margin analysis indicating how close your product is to passing or failing that specification. See Table 2 for a complete list of the measurements made by the N5412B SAS-2 compliance test software.

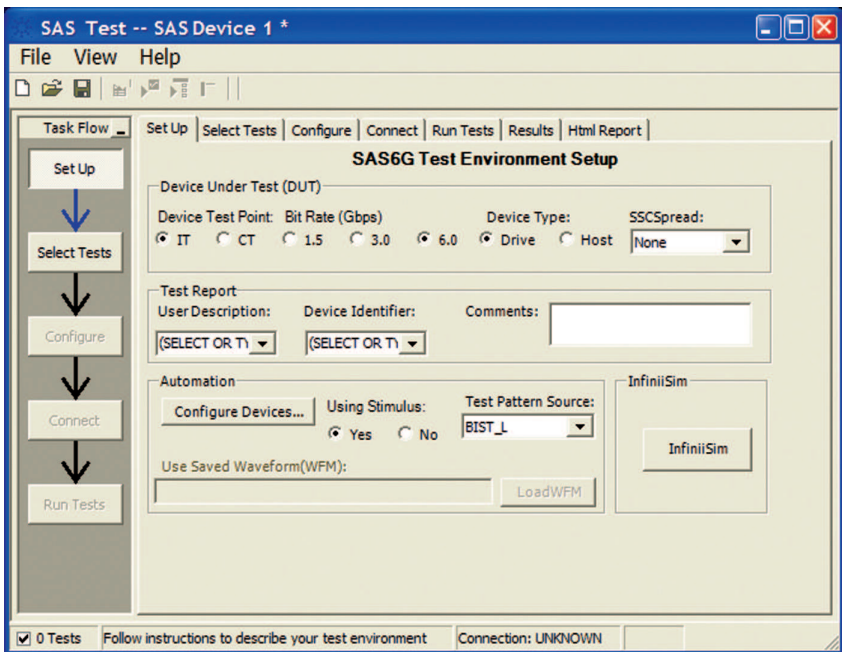

**Figure 1. The Agilent automated test engine guides you quickly through selecting and configuring tests, setting up the connection, running the tests, and viewing the results. You can easily select individual tests or groups of test with a mouse-click and customize your output report based on the test results you want to see.**

### Easy test definition

The N5412B SAS-2 compliance test software extends the ease-of-use advantages of Agilent's Infiniium Series oscilloscopes to testing SAS designs. The Agilent automated test engine walks you quickly through the steps required to define the tests, set up the tests, perform the tests, and view the test results. You can select a category of tests all at once, or specify individual tests. The user

interface is oriented to minimize unnecessary reconnections, which saves time and minimizes the potential for operator error. You can save tests and configurations as project files and recall them later for quick testing and review of previous test results. Straightforward menus let you perform tests with a minimum of mouse clicks.

## Configurability and guided connections

The N5412B SAS-2 compliance test software provides flexibility in your test setup. When the tests you select require it, the software guides you to make connection changes with hookup diagrams. The SAS electrical test software provides you with user-defined controls for critical test parameters, such as interface, line baud rate and number of unit intervals (UI) desired for the test group.

After configuring the tests according to your needs, the N5412B user interface displays the connection screen that is specific to the configuration data you have selected. This includes the oscilloscope channels used for the test and the routing of any necessary SMA cabling, power dividers and test fixtures needed to perform the tests.

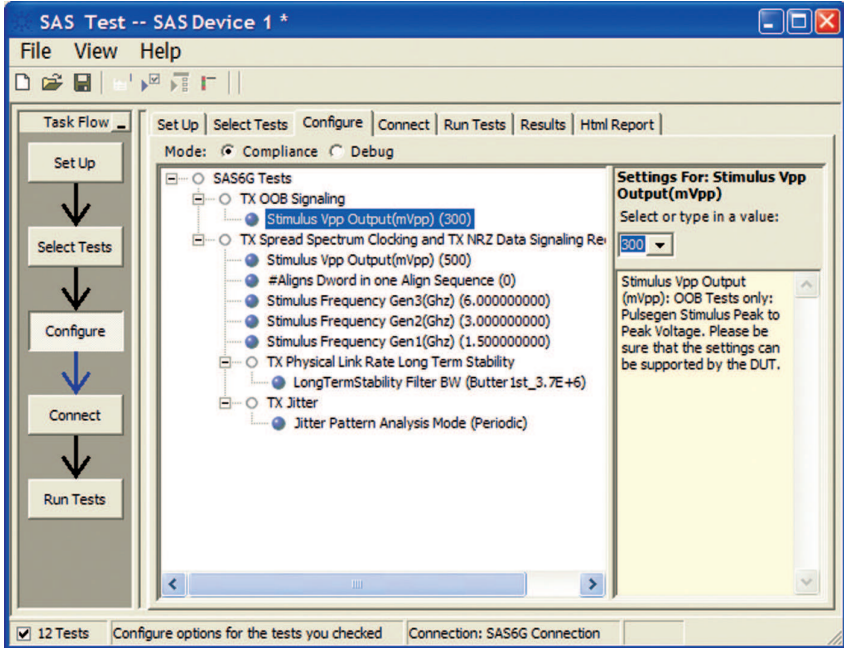

**Figure 2.** In configuring the tests, you define the number of UI to test, whether or not a TCTF load is being used and how the differential inputs and transient test probe are connected to the oscilloscope.

## Reports with margin analysis

In addition to providing you with measurement results, the N5412B SAS-2 compliance test software provides a report format that shows you not only where your product passes or fails, but also reports how close you are to the limits specified for a particular test assertion. You select the margin test report parameter, which means you can specify the level at which warnings are issued to alert you to the electrical tests where your product is operation close to the official test limit defined by the specification for a given test assertion.

### Thorough performance reporting

The N5412B SAS-2 compliance test software generates thorough reports that not only capture the performance and status of the device under test, but capture the screen shots of your most significant measurements for your documentation and evaluation.

### Measurement requirements

To use the N5412B SAS-2 compliance test software you will need an Agilent Infiniium Series oscilloscope with at least 12-GHz of analog, real-time bandwidth. You also will need N5400A EZJIT Plus jitter analysis software (Option 004 on new scopes) and E2688A serial data analysis/mask testing with clock recovery software (Option 003 on new scopes). The N5465A InfiniiSim waveform transformation toolset (option 014 on new scopes) for embed/de-embed is optional. In order to use the N5412B SAS compliance test software for compliance validation, your SAS chipset will need to be able to source the required compliance jitter tolerance pattern (CJTPAT) or jitter tolerance pattern (JTPAT) as defined in the SAS-2.1 specification, Annex A. The SCSI software command language provides a method for enabling these PHY test patterns in most chipsets by sending a "send diagnostic" command through a protocol-specific diagnostic page (see "Section 4.2 Phy test functions" of the SAS-2.1 Specification for details).

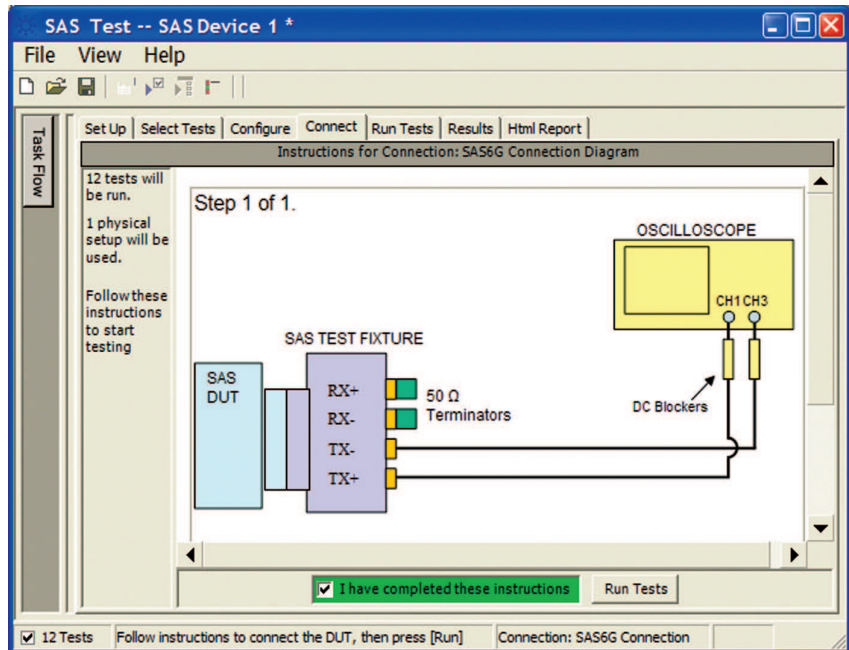

Figure 3. When you make multiple tests where the connections must be changed, the software prompts you with connection diagrams.

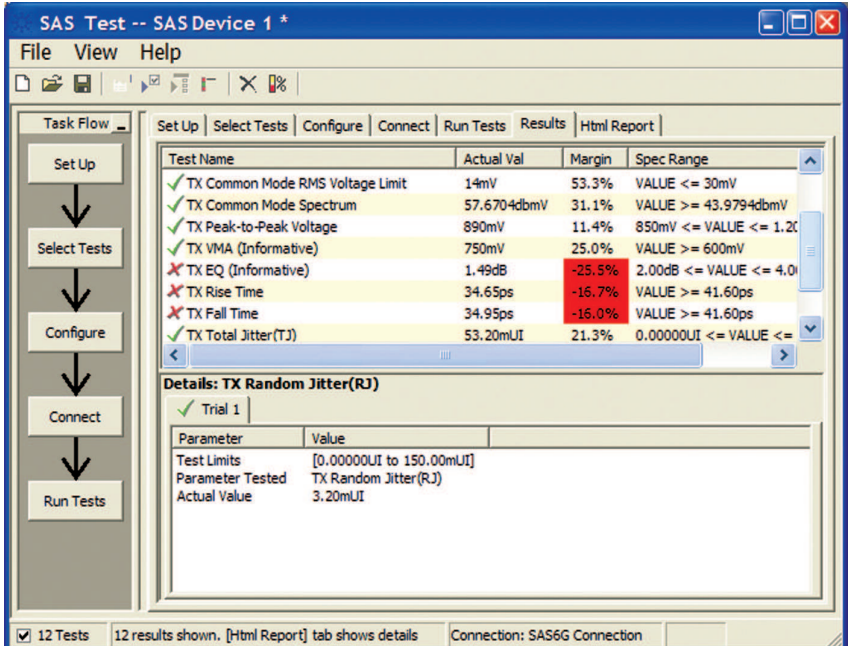

Figure 4. The SAS electrical test software results report documents you test, indicates the pass/fail status, the test specification range, the measured values and the margin.

## Extensibility

You may add additional custom tests or steps to your application using the N5467A User Defined Application (UDA) development tool ([www.agilent.com/find/uda](http://www.agilent.com/find/uda)). Use UDA to develop functional “Add-Ins” that you can plug into your application.

Add-ins may be designed as:

- Complete custom tests (with configuration variables and connection prompts)
- Any custom steps such as pre or post processing scripts, external instrument control and your own device control

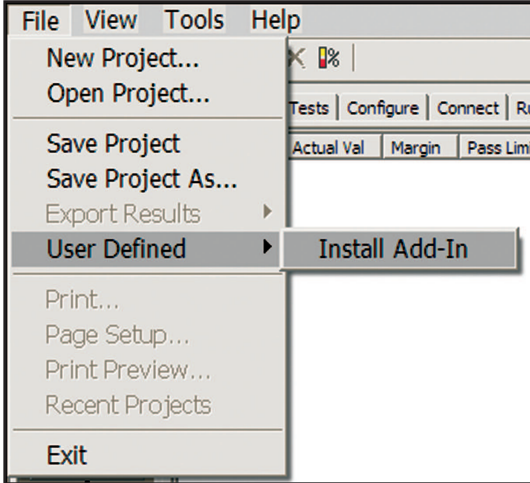

**Figure 5. Importing a UDA Add-In into your test application.**

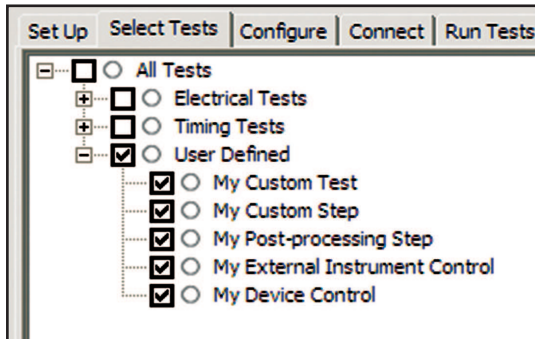

**Figure 6. UDA Add-In tests and utilities in your test application.**

## Automation

You can completely automate execution of your application's tests and Add-Ins from a separate PC using the included N5452A Remote Interface feature (download free toolkit from:

[www.agilent.com/find/scope-apps-sw](http://www.agilent.com/find/scope-apps-sw)).

You can even create and execute automation scripts right inside the application using a convenient built-in client.

The commands required for each task may be created using a command wizard or from "remote hints" accessible throughout the user interface.

Using automation, you can accelerate complex testing scenarios and even automate manual tasks such as:

- Opening projects, executing tests and saving results
- Executing tests repeatedly while changing configurations
- Sending commands to external instruments
- Executing tests out of order

Combine the power of built-in automation and extensibility to transform your application into a complete test suite executive:

- Interact with your device controller to place it into desired states or test modes before test execution.
- Configure additional instruments used in your test suite such as a pattern generator and probe switch matrix.
- Export data generated by your tests and post-process it using your favorite environment, such as MATLAB, Python, LabVIEW, C, C++, Visual Basic etc.
- Sequence or repeat the tests and "Add-In" custom steps execution in any order for complete test coverage of the test plan.

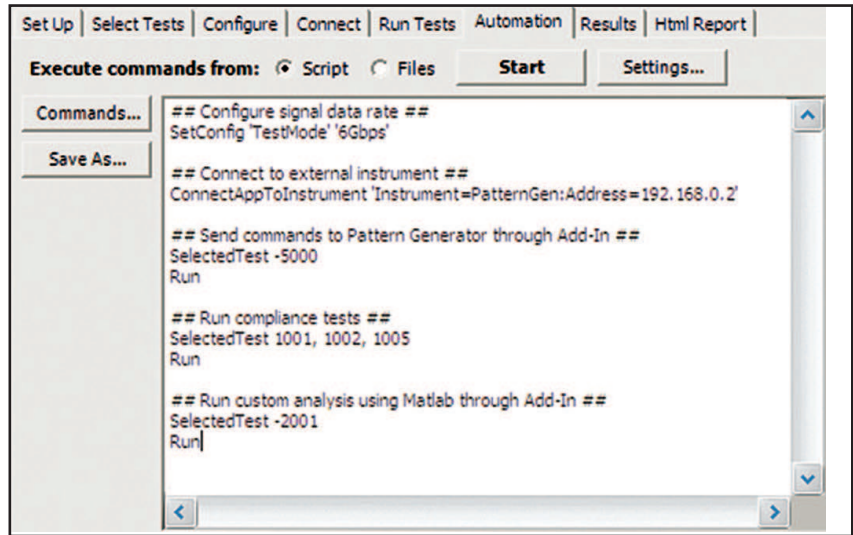

Figure 7. Remote Programming script in the Automation tab.

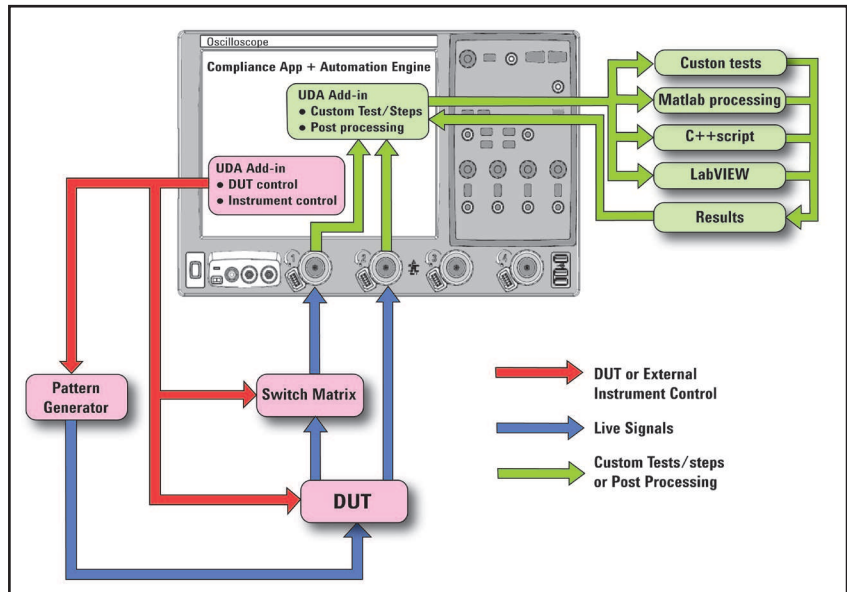

Figure 8. Combine the power of built-in automation and extensibility to transform your application into a complete test suite executive.

### Recommended test accessories

To complete your test setup, Agilent provides a wide range of cables, adapters, terminations, etc. Please note that the required equipment is listed in the Ordering Information summary. This list is provided for your convenience to accommodate necessary mating switches or additional debug capability.

Model number	Description
11667B	Power splitter, DC to 26.5 GHz, 3.5-mm (f) connectors Model number
11636B	Power divider, DC to 26.5 GHz, 3.5-mm (f) connectors
1250-1158	SMA (f-f) adapter, DC to 18 GHz
1250-1159	SMA (m-m) adapter, DC to 18 GHz
1250-1694	SMA (m) to SMA (f) adapter
15442A	Cable kit, four 90-cm (36-in) SMA (m-m) cables
15443A	Matched cable pair, two 90-cm (36-in) SMA (m-m) cables, propagation delay within 25 ps
1810-0118	SMA (m) 50 ohm termination
11742A	DC blocking capacitor, 0.045 to 26.5 GHz, 3.5-mm (m-f) connectors
N5421A	Serial attached SCSI IT/IR test fixtures for SFF-8482 SAS x2 internal plug/receptacle interfaces
IBNTST4X	Gore SMA breakout cable for SFF-8470 SAS x4 external receptacle interface tests (CT interface) (visit <a href="http://www.gore.com">www.gore.com</a> for purchasing information)
TCTF-SAS	Molex SFF-8470 SAS x4 external transmitter compliance transfer function (TCTF) for CR interface tests (contact <a href="mailto:scsi@molex.com">scsi@molex.com</a> for purchasing information)

**Table 1. Recommended test accessories**

### Oscilloscope compatibility

The N5412B SAS-2 compliance test software is compatible with Agilent Infiniium 90000 or 90000 X Series with version 3.50 or higher. For oscilloscopes with earlier software revisions, free upgrade software is available at

[www.agilent.com/find/scope-apps-sw](http://www.agilent.com/find/scope-apps-sw)

Data rate	Recommended oscilloscope	Bandwidth of recommended oscilloscope
1.5 Gbps only	DSO/DSA90804A	8 GHz
1.5 Gbps or 3.0 Gbps or 6.0 Gbps	DSO/DSA91204A	12 GHz
	DSO/DSA91304A	13 GHz
	DSO/DSAX91604A	16 GHz
	DSO/DSAX92004A	20 GHz
	DSO/DSAX92504A	25 GHz
	DSO/DSAX92804A	28 GHz
	DSO/DSAX93204A	33 GHz

**Note:**

A 12 GHz real-time oscilloscope is recommended to accurately measure the 42ps minimum risetime for 6.0 Gbps SAS signals and to provide full compliance to the specification.

## Tests performed

The N5412B SAS-2 compliance test software performs the following tests as per section 5.8, Tables 29-43 of the SAS-2.1 specification, by the T10/2125-0.

Test Parameters	Test Interfaces	
	IT	CT
<b>Data Signaling Tests</b>		
Physical link rate long-term stability	Table 29	Table 29
Common mode voltage limit (rms)	Table 33	Table 33
Common mode spectrum	Table 34	Table 34
Peak-to-peak voltage	Table 33	Table 33
Differential voltage swing (mode) (VMA)	Table 36	Table 36
Transmitter Equalization (EQ)	Table 36	Table 36
Rise/Fall Time	Table 33	Table 33
Total Jitter (TJ)	Table 33	Table 33
Random Jitter (RJ)	Table 33	Table 33
<b>SSC Signaling Tests</b>		
SSC Modulation Frequency	Table 52	Table 52
SSC Modulation Deviation and Balance	Table 52	Table 52
SSC DFDT (Informative)	Table 52	Table 52
<b>OOB Signaling Tests</b>		
Maximum noise during OOB idle	Table 27	Table 27
Minimum OOB burst amplitude	Table 38	Table 38
OOB offset delta	Table 38	Table 38
OOB common mode delta	Table 38	Table 38
Receive COMINIT idle time	Table 61	Table 61
Receive COMSAS idle time	Table 61	Table 61

**Table 2. SAS transmitted signal electrical characterization tests performed by the N5412B software**

## Ordering information

To purchase the N5412B SAS-2 compliance test software with a new or existing Infiniium Series oscilloscope, order the model numbers shown:

Model number	Description
N5400A	EZJIT Plus jitter analysis software (Option 004 on new oscilloscopes)
E2688A	Serial data analysis/mask testing with clock recovery software (Option 003 on new oscilloscopes)
N5412B-001	SAS-2 6Gbps compliance test software upgrade for Infiniium 90000 and 90000 X Series oscilloscopes - requires the N5412A license
N5412B-002	SAS-2 compliance test software for 90000 and 90000 X-Series oscilloscopes (Option 043 on new oscilloscopes)
N6171A-M01	Matlab basic software package for running WDP tests - WDP script is not provided by Agilent, user is responsible to obtain the script from the SAS standards (Option 061 on new oscilloscopes)
N2801A-001 or	PrecisionProbe for 90000X series oscilloscope - optional (Option 001 on new oscilloscopes)
N2801A-002	PrecisionProbe for 90000 series oscilloscope - optional (Option 001 on new oscilloscopes)
N5465A	InfiniiSim waveform transformation toolset - optional (Option 014 on new oscilloscopes)
81134A or	Pulse pattern generator, 3.35 GHz dual-channel
N4903B	High-performance serial BERT with Option 002
<b>For complete electrical performance validation and compliance you will also need to order the following accessories:</b>	
11636B	Power divider, DC to 26.5 GHz, 3.5-mm (f) connectors (need qty. 2)
5062-6681	Cable assembly 6 in. SMA (need qty. 4)
11742A	DC blocking capacitor, 0.045 to 26.5 GHz, 3.5-mm (m-f) connectors (need qty. 2)
N5421A	Serial attached SCSI IT/CT test fixtures for SFF-8482 SAS x2 internal plug/receptacle interface
15442A	Cable kit, four 90-cm (35-in) SMA (m-m) cables (or equivalent SMA cables 24-in or 36-in; need qty. 4)

## Related Literature

Publication Title	Publication Type	Publication Number
<i>Infiniium 90000 Series Oscilloscopes</i>	Data sheet	5989-7819EN
<i>Infiniium 90000 X-Series Oscilloscope</i>	Data sheet	5990-5271EN
<i>N5400A EZJIT Plus and EZJIT Jitter Analysis Software for Infiniium Series Oscilloscopes</i>	Data sheet	5989-0109EN
<i>Agilent Technologies E2688A, N5384A High-Speed Serial Data Analysis and Clock Recovery Software for Infiniium Oscilloscopes</i>	Data sheet	5989-0108EN
<i>Agilent Technologies N5465A: InfiniiSim Waveform Transformation Toolset for the Infiniium Series Oscilloscopes</i>	Data sheet	5990-4059EN
<i>Agilent Technologies 81133A and 81134A 3.35 GHz Pulse Pattern Generators</i>	Data sheet	5988-5549EN

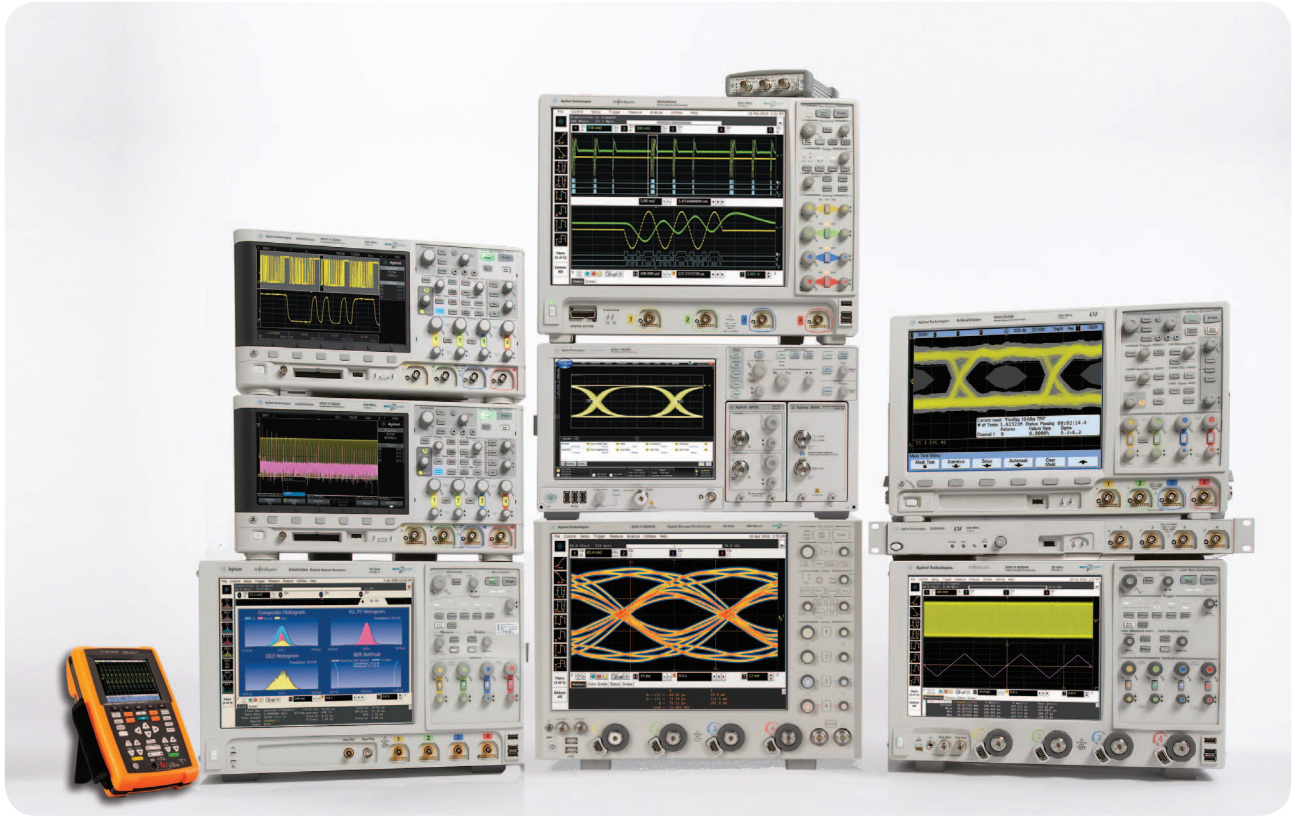

## Agilent Technologies Oscilloscopes

Multiple form factors from 20 MHz to >90 GHz | Industry leading specs | Powerful applications



**myAgilent**

[www.agilent.com/find/myagilent](http://www.agilent.com/find/myagilent)

A personalized view into the information most relevant to you.



[www.axistandard.org](http://www.axistandard.org)

AdvancedTCA® Extensions for Instrumentation and Test (AXIe) is an open standard that extends the AdvancedTCA for general purpose and semiconductor test. Agilent is a founding member of the AXIe consortium.



[www.lxistandard.org](http://www.lxistandard.org)

LAN eXtensions for Instruments puts the power of Ethernet and the Web inside your test systems. Agilent is a founding member of the LXI consortium.



[www.pxisa.org](http://www.pxisa.org)

PCI eXtensions for Instrumentation (PXI) modular instrumentation delivers a rugged, PC-based high-performance measurement and automation system.

### Agilent Channel Partners

[www.agilent.com/find/channelpartners](http://www.agilent.com/find/channelpartners)

Get the best of both worlds: Agilent's measurement expertise and product breadth, combined with channel partner convenience.



Agilent Advantage Services is committed to your success throughout your equipment's lifetime. To keep you competitive, we continually invest in tools and processes that speed up calibration and repair and reduce your cost of ownership. You can also use Infoline Web Services to manage equipment and services more effectively. By sharing our measurement and service expertise, we help you create the products that change our world.

[www.agilent.com/find/advantageservices](http://www.agilent.com/find/advantageservices)



[www.agilent.com/quality](http://www.agilent.com/quality)

[www.agilent.com](http://www.agilent.com)  
[www.agilent.com/find/N5412A](http://www.agilent.com/find/N5412A)

For more information on Agilent Technologies' products, applications or services, please contact your local Agilent office. The complete list is available at:

[www.agilent.com/find/contactus](http://www.agilent.com/find/contactus)

### Americas

Canada	(877) 894 4414
Brazil	(11) 4197 3600
Mexico	01800 5064 800
United States	(800) 829 4444

### Asia Pacific

Australia	1 800 629 485
China	800 810 0189
Hong Kong	800 938 693
India	1 800 112 929
Japan	0120 (421) 345
Korea	080 769 0800
Malaysia	1 800 888 848
Singapore	1 800 375 8100
Taiwan	0800 047 866
Other AP Countries	(65) 375 8100

### Europe & Middle East

Belgium	32 (0) 2 404 93 40
Denmark	45 45 80 12 15
Finland	358 (0) 10 855 2100
France	0825 010 700*
	*0.125 €/minute
Germany	49 (0) 7031 464 6333
Ireland	1890 924 204
Israel	972-3-9288-504/544
Italy	39 02 92 60 8484
Netherlands	31 (0) 20 547 2111
Spain	34 (91) 631 3300
Sweden	0200-88 22 55
United Kingdom	44 (0) 118 927 6201

*For other unlisted countries:*

[www.agilent.com/find/contactus](http://www.agilent.com/find/contactus)

Revised: October 11, 2012

Product specifications and descriptions in this document subject to change without notice.

© Agilent Technologies, Inc. 2012  
Published in USA, December 18, 2012  
5990-6308EN



**Agilent Technologies**