

ZC1003

SMD Z AXIS COIL Low Profile

10x10x3 mm (2.38 mH - 16.2 mH)

Features

This SMD coil offers a very low profile solution for applications in which it's needed a transponder vertical coil with high sensitivity in z direction and in a small surface area. It's so a lower profile solution for those applications in which the height of the component is critical. The design combines the best electrical performance in these dimensions together with mechanical robustness.

Dimensions

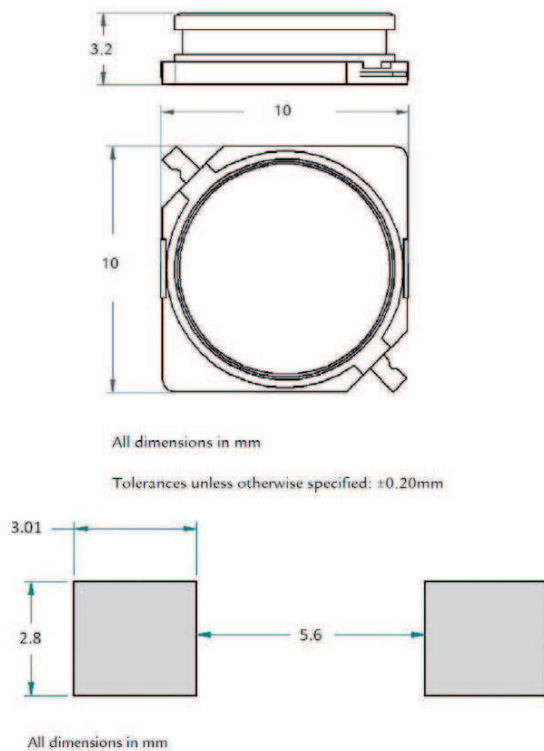

Electrical specifications

P/N	L (mH)	Cres (pF)	Q	SRF (kHz)	RDC (Ω) max.	Sensitivity (mVpp/App/m)
ZC1003-0238J	2.38	680	>55	>800	27	>20
ZC1003-0491J	4.91	330	>50	>500	60	>30
ZC1003-0720J	7.20	225	>55	>450	75	>35
ZC1003-0900J	9.00	180	>60	>400	85	>40

This chart is a reference guide for the most common required values at working frequency of 125 kHz. Any other inductance value at LF or tighter tolerances can be provided. Please contact our sales department for any inquiry.

L and Q factor measured at 125 kHz, 1 Vac.

Sensitivity measured with Helmholtz coils $H=8.36$ App/m @125 kHz. Contact us for measurement specification.

SRF: Self Resonant Frequency of the coil.

Applications

Automotive.

- Passive Keyless Entry and Keyless Go Systems.
- RTPMS with wake up functions. Industrial logistics and control.
- Access control.
- Tracking devices.

Keyless Entry Systems is a typical application for this coil where performs high sensitivity in a very small package and with the advantage of easy SMD assembly. This design shows also very good sensitivity performance in angle deviation from z axes.

Characteristics

- Standard size 10x10x3 mm.
- Very good electrical and mechanical performance.
- High stability in temperature (-40°C to +125°C).
- Inductivity value can be customized to achieve customer requirements.
- Designs at lower frequencies such as 20 kHz and 40 kHz show a very good electrical performance as well.
- High sensitivity values achieved with very good thermal and mechanical performance.
- This component is also functional to 20kHz and 134kHz.