

TP0702

7.7x3x2.2 mm (2.38 mH - 10.8 mH)

SMD Hard Ferrite Mechanically Improved Transponder Inductor

Features

This TP0702 Series of Surface Mountable ferrite wound inductor is a stronger solution in very small dimensions performing very good electrical properties, a very good solution for RTPMS, Keyless Go and Keyless entry systems.

Characteristics:

- Size: 7.7 x 3 x 2.2 mm.
- Very good mechanical performance.
- High sensitivity in the smallest volume.
- Very stable electrical properties in full operational temperature range (-40 → +125 °C).
- Good performance in thermal shock.
- Big metallised pad area Pb free.
- Good cost/performance ratio.
- Due to its small dimensions, it's a suitable design for other applications working at lower frequencies.
- This component is also functional to 20kHz and 134kHz.

Dimensions

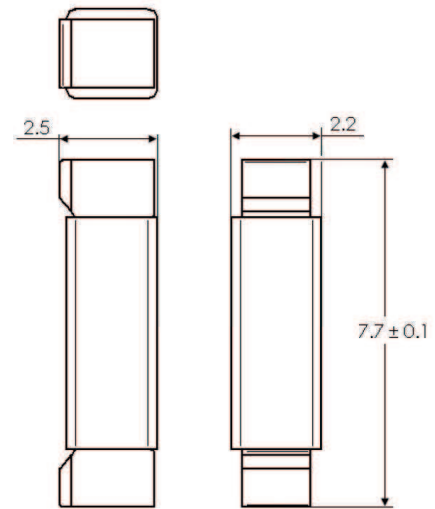

All dimensions in mm

Tolerances unless otherwise specified: ±0.20mm

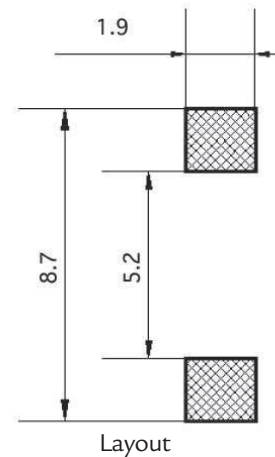

Electrical specifications

| P/N | L (mH) @125 kHz | Tolerance | Cres (pF) | Q @125 kHz | SRF (kHz) | Sensitivity (mVpp/App/m) @125 kHz |
|--------------|--------------------|-----------|-----------|------------|--------------|---|
| TP0702-0238J | 2.38 | ±5% | 680 | >30 | >750 | >25 |
| TP0702-0491J | 4.91 | ±5% | 330 | >35 | >550 | >35 |
| TP0702-0720J | 7.20 | ±5% | 225 | >20 | >450 | >49 |
| TP0702-0900J | 9.00 | ±5% | 180 | >25 | >400 | >53 |

This chart is a reference guide for the most common required values at working frequency of 125 kHz. Any other inductance value at LF or tighter tolerances can be provided. Please contact our sales department for any inquiry.

Sensitivity measured with Helmholtz coils H=8.36 App/m @125 kHz. Contact us for measurement specification.

SRF: Self Resonant Frequency of the coil.

Cres: Capacitor for tuning circuits (125 kHz).

- Terminals: Ag-Ni-Sn100.
- Wire: H, 180 °C, Solderable.
- Refer to the General Features of SMD transponder inductors page.