

STP SERIES

High Power Chokes for EMC DC/DC Converters

Features

- DC Chokes for Outputs Stages DC-DC Converters
- Designed to be useful in Automotives electronics
- Up to 65A DC currents with Extra low DC resistance
- Current Ripple up to 4-30% of DC Values
- Operating Temperature -40 to 125 °C.
- Power rating : up to 350W
- Inductance range : 12 to 2.4 μ H
- Frequency range : 50-400kHz
- Very stable performances versus temperature
- No thermal aging effect
- UL94V-0 material
- RoHS compliant

General Application

- Automotive embedded DC-DC Converters
- Power Ratings According "Start-Stop" Converters
- Industrial Small power SMPS

Specific Application

- STP-14-22 can be used as storage inductor for main converter topologies, like buck, boost, buck-boost or inductor output stage in Forward, Push-Pull, Half-Bridge or Full Bridge converters, . In order to maintain the core losses in acceptable levels continuous conduction mode without not 30% bigger values ripples of nominal current.
- STP-02-65 and STP-08-30 can be used as differential inductor elements in output filter stages, where the ripple are low, and the DC inductance are high.
- All codes can be used in whatever application. In order to help the designers, we show the thermal response, DC bias and AC losses of each one depending on the operation conditions.



STP-02-65
STP-08-30

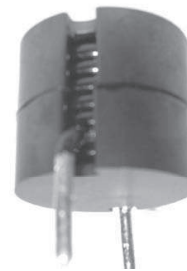

STP-14-22

Electrical specifications

Code	Freq. (kHz)	Lo ⁽²⁾ \pm 10% (μ H)	L MIN at Peak Current (μ H)	DCR MAX (m Ω)	Current Idc (A)	Ripple Δ Ipp (A)	Copper Losses @100°C (W)	Core Losses @100°C (mW)	Weight (g)
STP-02-65	100kHz	2,40	> 1,95@65A	0,60	65	3	2,5	150	55
STP-08-30	100kHz	9,70	> 8,00@30A	2,25	30	1,5	2,0	150	55
STP-14-22	100kHz	14,5	> 13@25A	3,5	22	6	2,2	200	55

Notes

- (1) All test data are referenced to 25°C ambient temperature
- (2) Inductance values are measured at 100kHz/0.25V
- (3) See L vs. Idc curve beside
- (4) Dielectric strength between winding and core is greater than 300Vac/50Hz/2sec
- (5) Core Losses referred to the peak to peak ripple current specified on the table.

STP SERIES

High Power Chokes for EMC DC/DC Converters

Typical Inductance Values vs DC BIAS

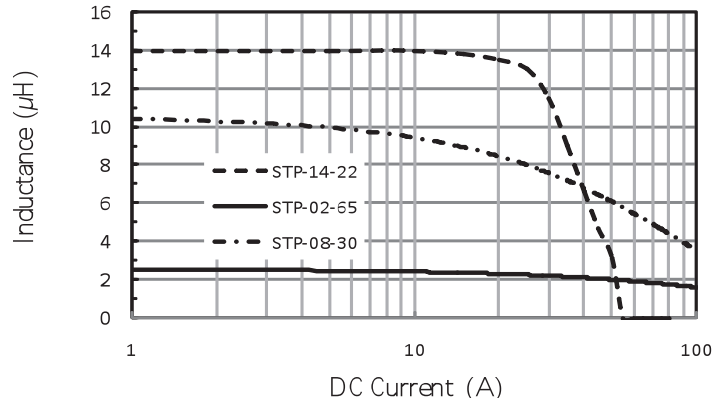

Notes : Inductance measured at @100kHz/100mVac.

Typical performances versus temperature

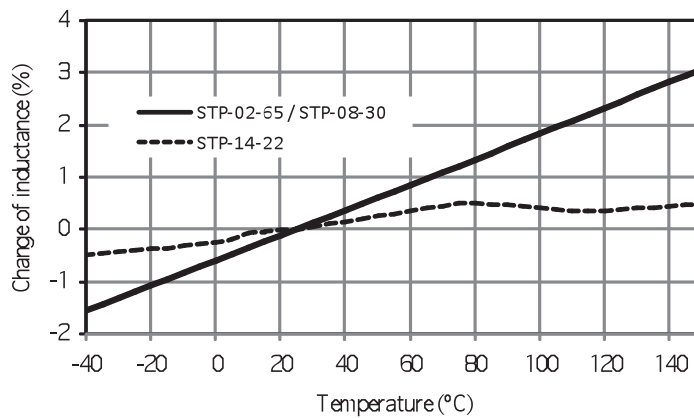

Notes : Inductance measured at @100kHz/100mVac.

Core Losses vs Frequency and Ripple Currents

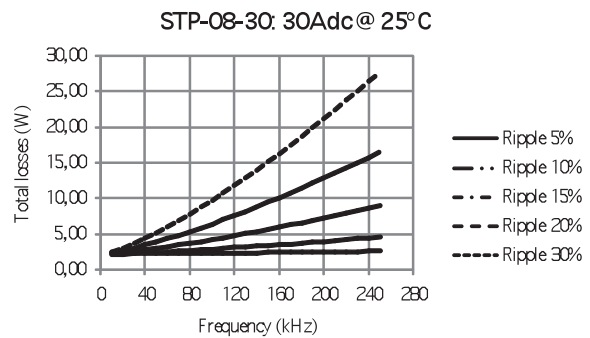
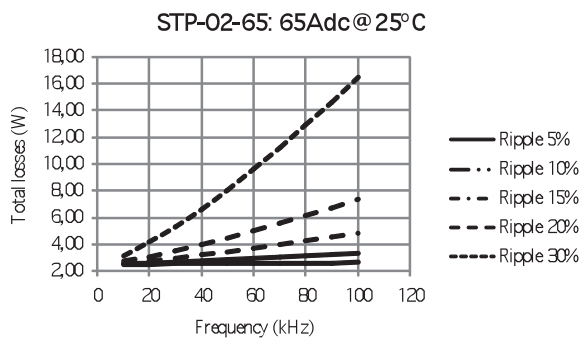

Notes : Total core losses estimated at given conditions. Losses includes core , copper losses and all the second order losses as eddy currents on copper and skin effect. DC currents according nominal values.

STP SERIES

High Power Chokes for EMC DC/DC Converters

High Power Chokes for EMC and DC/DC Converters

Typical Inductance Values vs DC BIAS

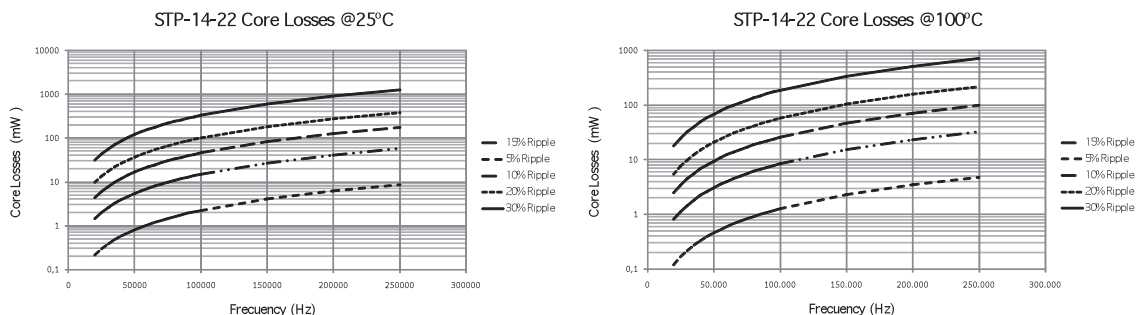

Notes : Estimated core losses for the core material. The losses are presented for different current ripple on the choke, referred to nominal values, and for operation temperature of 25 and 100 °C.

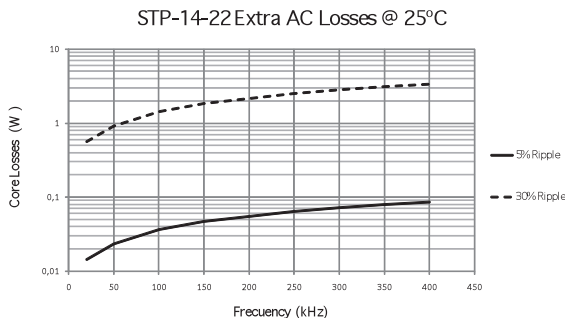

Notes : Estimated core losses for the core material. The losses are presented for different current ripple on the choke, referred to nominal values, and for operation temperature of 25 and 100 °C.

Impedance vs Frequency

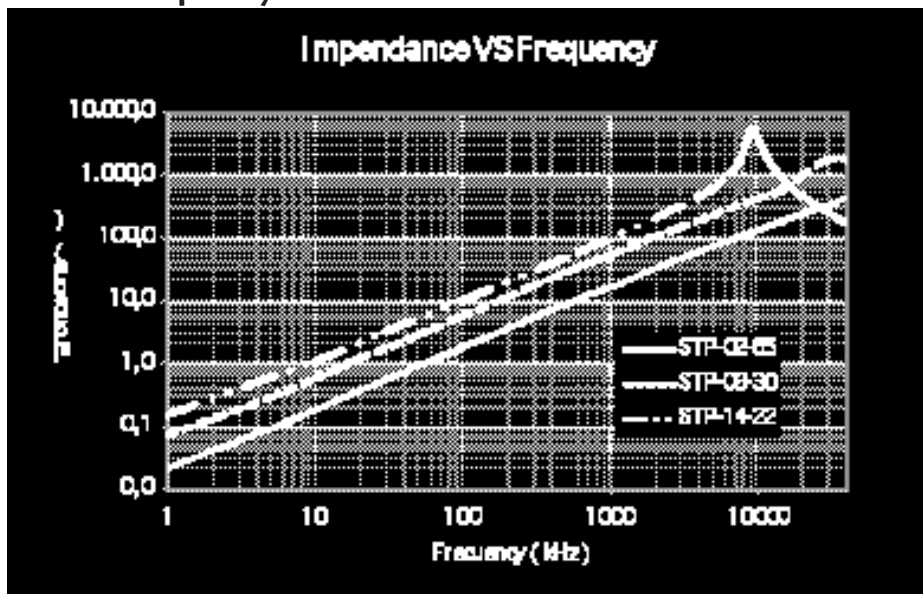

Notes : Series Impedance.

STP SERIES

High Power Chokes for EMC DC/DC Converters

Thermal Behavior

The final temperature of the magnetic will depend on the total power losses being dissipated on the chokes. As a first approximation, the rise temperature expected can be estimated using the formula as per below:

$$\Delta T(^{\circ}\text{C}) = \left(\frac{P}{S} \right)^{0.83}$$

Where:

P is total power losses expected according above core data and given conditions, in mW.
S is a constant depending on magnetic morphology, use 22 for STP-02 and 08. Use 27,5 for STP-14.

The result will give the estimated temperature rise.

Dimensions

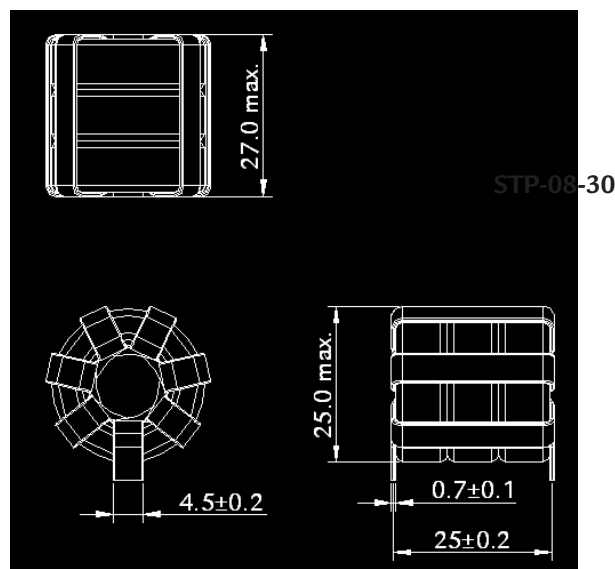
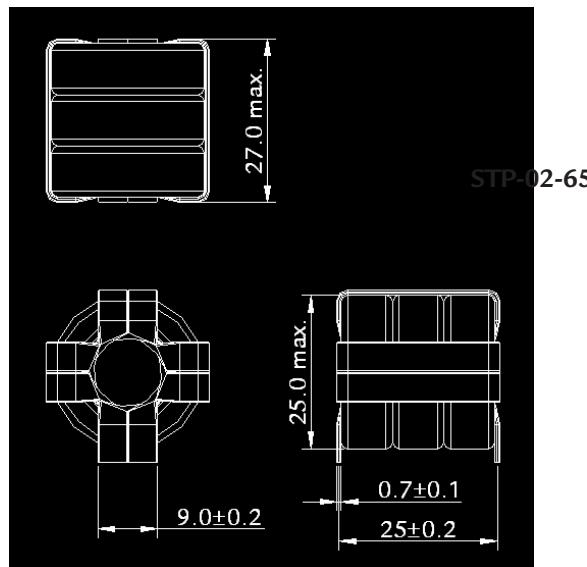

STP SERIES

High Power Chokes for EMC DC/DC Converters

High Power Chokes for EMC and DC/DC Converters

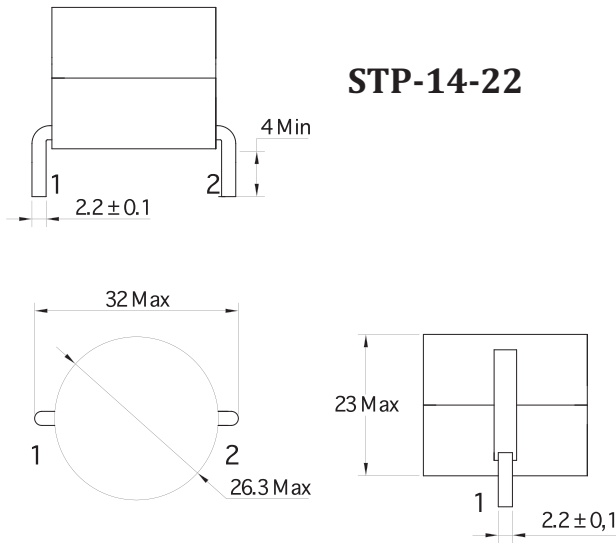

STP-14-22

Recommended PCB Layout.

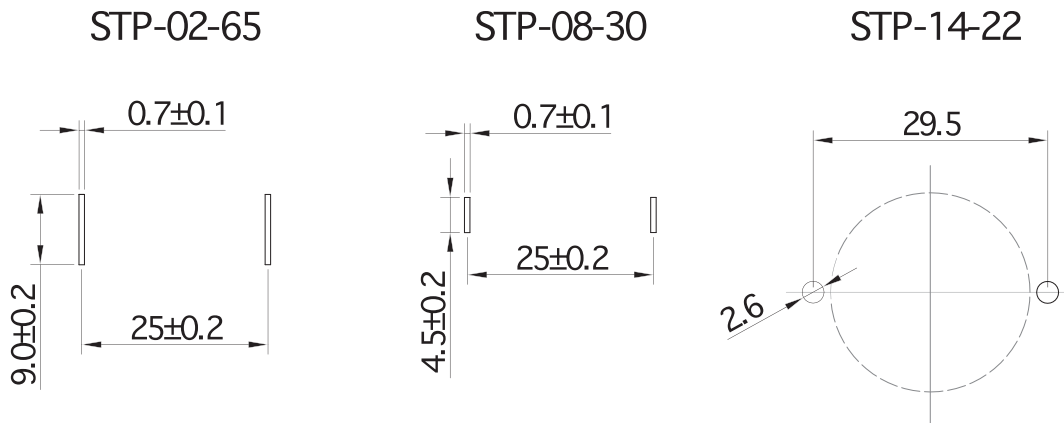

Notes : View in mounting direction.

Packaging

Antistatic trays with carton grids in carton box