

POE

Transformers for 3W, 7W and 13W applications

Standard SMPS Transformers

Features

- Application: Powered devices in IEEE802.3 af-compliant Power over Ethernet (PoE) applications
- Topology: Flyback transformer with continuous mode
- Frequency: 250 kHz
- Input voltage: 36-72Volts
- Power: 3W, 7W, 13W
- Operating temperature range: -40~+85 °C
- Isolation: 1500Vrms between primary and bias winding to the secondary winding
- Rohs compliant

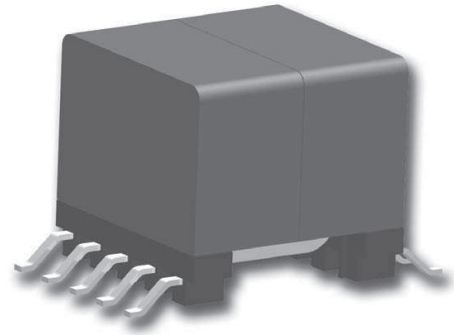

Electrical specifications

Part Number	Power W	Input		Output		L ⁽¹⁾ (±10%) μH	DCR nom			Lleak ⁽²⁾ REF μH	Turns ratio ⁽³⁾		Format
		V (dc) V	I (max) A	V (dc) V	I (max) A		Pri Ω	Bias Ω	Sec1&2 Ω		Pri:Sec	Pri:Bias	
POE03-033	3	36-72	0,40	3,3	0,91	310	1,48	3,70	0,090	4,0	1:0,19	1:0,70	EP7
POE03-050	3	36-72	0,40	5,0	0,6	310	1,48	3,70	0,180	3,0	1:0,28	1:0,70	EP7
POE03-120	3	36-72	0,40	12	0,25	310	1,48	3,70	0,970	2,8	1:0,70	1:0,70	EP7
POE07-033	7	36-72	0,85	3,3	2,12	155	0,54	2	0,045	3,5	1:0,19	1:0,667	EP10
POE07-050	7	36-72	0,85	5,0	1,4	155	0,54	2	0,073	3,0	1:0,262	1:0,667	EP10
POE07-120	7	36-72	0,85	12	0,6	155	0,54	2	0,500	2,0	1:0,667	1:0,667	EP10
POE13-033	13	36-72	1,3	3,3	4	127	0,29	0,37	0,021	1,30	1:0,166	1:0,50	EP13
POE13-050	13	36-72	1,3	5,0	2,6	127	0,25	0,37	0,039	1,60	1:0,25	1:0,50	EP13
POE13-120	13	36-72	1,2	12	1,08	127	0,26	0,37	0,150	1,20	1:0,50	1:0,50	EP13
POE13-195	13	36-72	1,0	19,5	0,67	127	0,25	0,37	0,210	1,15	1:0,567	1:0,50	EP13
POE13-240	13	36-72	1,0	24	0,54	127	0,25	0,37	0,300	1,10	1:0,667	1:0,50	EP13

Note 1: Inductance measured at 250kHz 0.1Vrms, 0A dc

Note 2: Leakage inductance measured between primary with all others pins shorted. Measure at 250kHz, 0.1Vrms.

Note 3: Turns ratio with the secondary windings connected in parallel.

Test condition: 25 °C

Electrical diagram

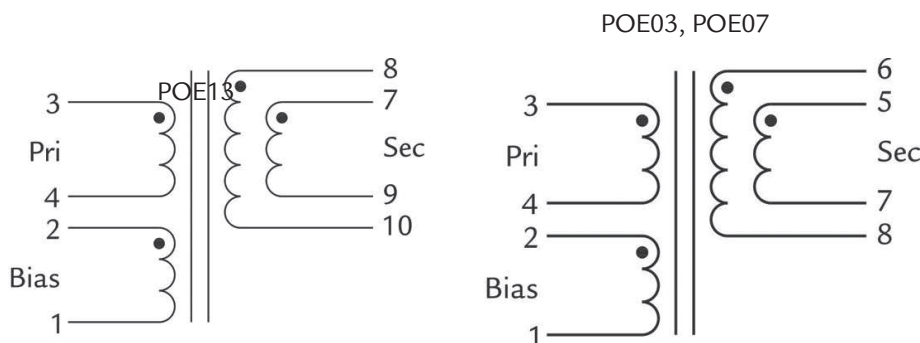

POE

Transformers for 3W, 7W and 13W applications

Dimensions

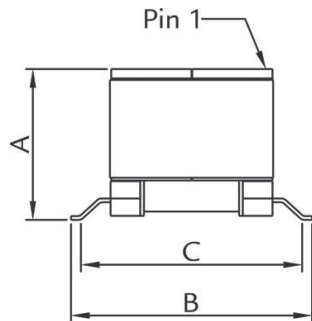

Front View

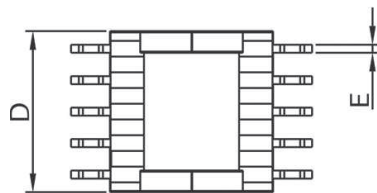

Bottom View

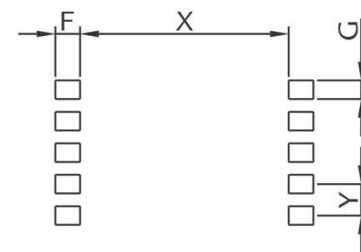

Top View
Recommended PCB Layout

Dimensions (mm)

Part Number	A	B	C (ref)	D	E	F	G	X	Y
POE03-	9,1	13,3	10,6	11,0	0,7	2,03	1,27	9,40	2,5
POE07-	11,0	15,3	12,5	12,7	0,6	2,03	1,27	11,68	2,5
POE13-	12,5	17,8	15,4	13,5	0,7	1,80	1,27	14,99	2,50