

PBP19 SERIES

Planar chokes 19.81x19.56x7.4

Features

- High density storage choke for telcomm and industrial application
- Height : 7.4mm Max, Pick&Place compatible
- Planar ferrite core format design
- RMS current rating : up to 52A
- Inductance range : 0.45 μ H to 5.80 μ H
- Frequency range up to 1MHz
- Very Low core losses
- Operating temperature up to 125°C
- Very stable performances versus temperature



High Power SMD Chokes

Application

- Low-profile high-current DC/DC converters
- DC/DC converters for FPGA
- High current POL converters
- DC/DC converters in distributed power systems

Electrical specifications

Code	L0 ⁽³⁾ INDUCTANCE ±15% (μ H) at 0.25V/100kHz/0A	DCR TYP at 25°C (m Ω)	DCR MAX at 25°C (m Ω)	HEATING CURRENT Idc ⁽⁴⁾ (ADC)	LOAD INDUCTANCE ±15% (μ H) at 0.25V/100kHz/ Irated
2 TURNS IN SERIES					
PBP19-0R45-2	0.45	78	98	52	0.45
PBP19-0R63-2	0.65	78	98	52	0.63
PBP19-0R85-2	0.91	78	98	39	0.85
PBP19-1R05-2	1.10	78	98	30	1.05
PBP19-1R25-2	1.30	78	98	25	1.25
PBP19-1R45-2	1.50	78	98	21	1.45
3 TURNS IN SERIES					
PBP19-0R95-3	1.0	1.15	1.43	42	0.95
PBP19-1R40-3	1.5	1.15	1.43	36	1.40
PBP19-1R90-3	2.0	1.15	1.43	25	1.90
PBP19-2R40-3	2.5	1.15	1.43	20	2.40
PBP19-2R80-3	3.0	1.15	1.43	15	2.80
PBP19-3R40-3	3.5	1.15	1.43	12	3.40
4 TURNS IN SERIES					
PBP19-1R60-4	1.60	1.44	1.80	37	1.60
PBP19-2R40-4	2.42	1.44	1.80	30	2.40
PBP19-3R30-4	3.60	1.44	1.80	17	3.30
PBP19-4R00-4	4.40	1.44	1.80	14	4.00
PBP19-4R90-4	5.34	1.44	1.80	11	4.90
PBP19-5R80-4	6.20	1.44	1.80	9	5.80

PBP19 SERIES

Planar chokes 19.81x19.56x7.4

High Power SMD Chokes

- (1) All test data are referenced to 25°C ambient temperature
- (2) Continuous operating temperature range must be within -40°C/+125°C (ambient + self heating) under worst case conditions; exposure to 150°C peak is allowed according to IEC85 F thermal index for all raw materials used
Circuit design, component placement, PCB tracks size and thickness, airflow and other cooling provisions all affect the part temperature rise
It is suggested that the component be tested at the system level to verify its temperature after 30 minutes in the end application
- (3) +/-10% MAX on -40°C/+125°C temperature range
- (4) DC current that will cause an approximate ΔT of +50°C

Dimensions (mm)

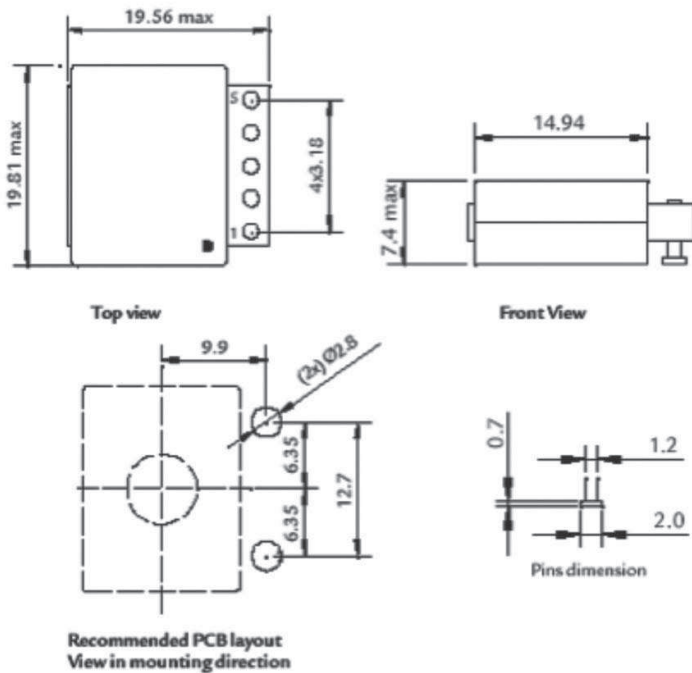

Turns	Input Pin	Output Pin	Pin Distance
2	1	3	6.35mm
3	1	4	9.53mm
4	1	5	12.7mm

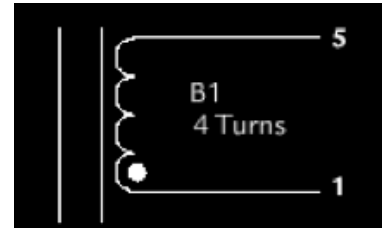

Note : PCB layout referred to 4 turns version. Refer to table to PCB layout for 2 and 3 turns version

Soldering

Reflow soldering process is compatible to mount components from the PBP series
A maximum soldering temperature of 260°C during 10s shall not be exceeded
The reflow condition recommended beside is according to the equipment used at PREMO
Differences could appear as a result of the type of machine, reflow conditions, method...

