

HC SERIES

Common mode chokes with Nanocrystalline cores

Features

- Nominal current in each winding (I): from 2A to 30A.
- Nominal inductance (L): from 6mH to 28mH.
- Rated voltage: 250Vac.
- Test voltage: 1.5kVac, winding to winding.
- Creepage distance: 3mm, winding to winding.
- Ambient temperature: from -40°C to +50°C.
- Storage temperature: from -40°C to +120°C.
- Plastic case: UL 94V-0 listed.
- According to UL 1283.

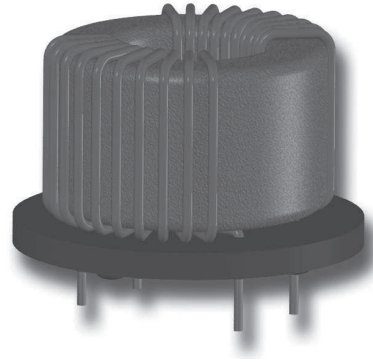

Electrical specifications

Code	I _{AC} (A)	L (mH) at 10kHz +50% / -30%	L (mH) at 100kHz minimum	IZI (Ω) at 100kHz typical	R _{dc} (mΩ) typical	ØPIN (mm) ±0,1
HC140-02V1	2	2 x 14	2 x 1,5	2000	110	0,5
HC6R5-04V1	4	2 x 6,5	2 x 0,65	1600	31,5	0,75
HC280-04V1	4.5	2 x 28	2 x 4,5	4500	42	0,7
HC190-06V2	6	2 x 19	2 x 2,7	3500	37	0,8
HC130-08V2	8	2 x 13	2 x 1,8	2000	20	0,95
HC9R0-10V2	10	2 x 9	2 x 1,4	1500	18	0,9
HC110-13V2	13	2 x 11	2 x 1,3	1600	11	1,25
HC6R0-15V3	15	2 x 6	2 x 2,0	1000	10	1,2
HC6R0-30V3	30	2 x 6	2 x 0,5	1000	3	2,2
HC9R0-10H1	10	2 x 9	2 x 1,4	1500	18	0,9
HC110-13H1	13	2 x 11	2 x 1,3	1600	10	1,25
HC1R6-20H1	20	2 x 1,6	2 x 0,2	250	3	1,6
HC130-16H2	16	2 x 13	2 x 1,2	1800	6,6	1,6
HC1R2-25H2	25	2 x 1,2	2 x 0,4	370	3	1,8
HC4R9-20H3	20	2 x 4.9	2 x 1,4	1600	7	1,7
HC3R6-25H3	25	2 x 3,6	2 x 1,1	1000	5,5	1,8
HC2R6-32H3	32	2 x 2,6	2 x 0,3	400	2,5	2,2

HC SERIES

Common mode chokes with Nanocrystalline cores

Dimensions (in mm)

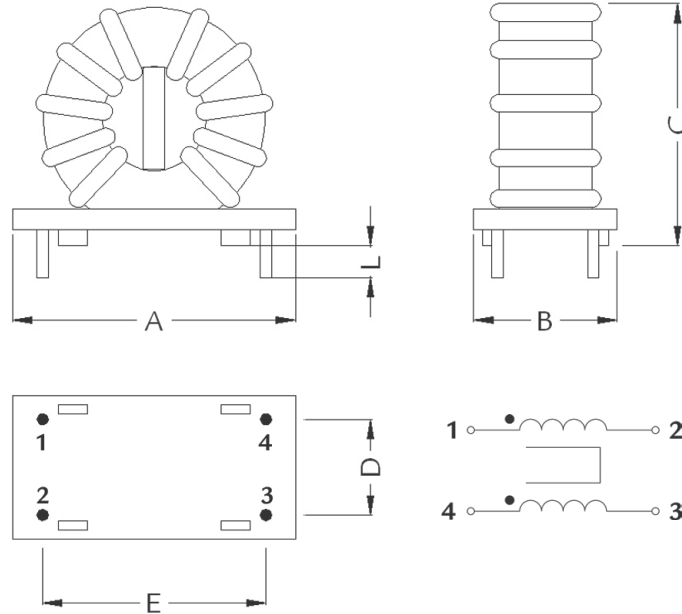

Code	A MAX	B MAX	C MAX	D ±0,2	E ±0,2	L ±1,0
HC-V1	28,5	18	30	7,62	15,24	4
HC-V2	37,0	22	37	15,24	25,4	4
HC-V3	55,0	30	56	20,32	35,56	5

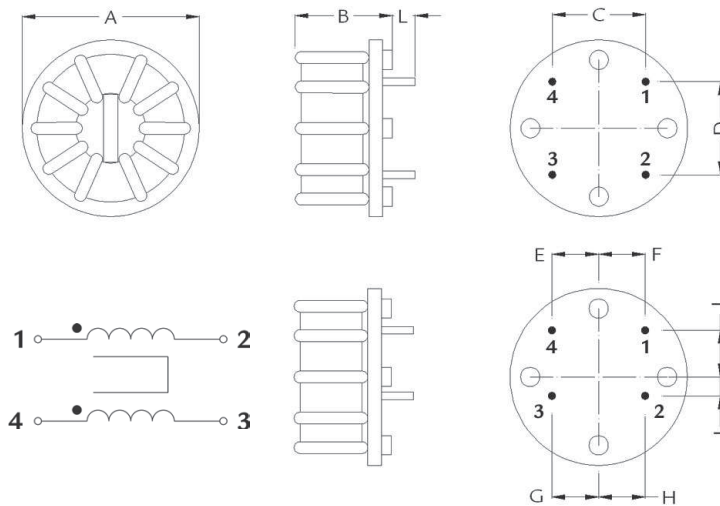

Code	A MAX	B MAX	C ±0,2	D ±0,2	E ±0,2	F ±0,2	G ±0,2	H ±0,2	I ±0,2	J ±0,2	L ±1,0
HC-H1	37,5	23	13,5	23	-	-	-	-	-	-	4
HC-H2	42,5	26	-	-	5	5	5	5	7	15	5
HC-H3	55,5	31	-	-	12,5	10	7,5	7,5	4,5	20	5

HC SERIES

Common mode chokes with Nanocrystalline cores

Curves: Impedance vs. Frequency

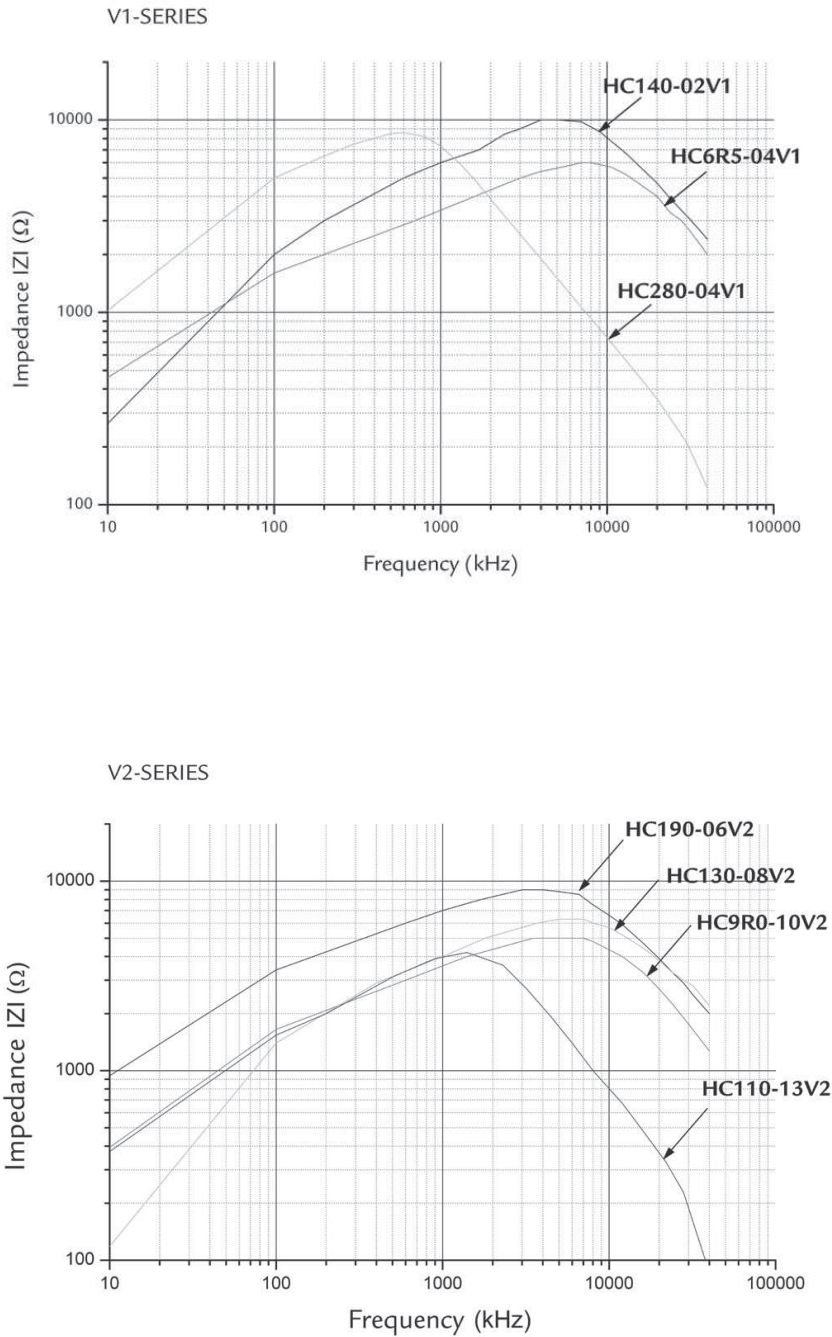

Note:

Impedance measurements have been obtained with both windings in parallel and at ambient temperature.

HC SERIES

Common mode chokes with Nanocrystalline cores

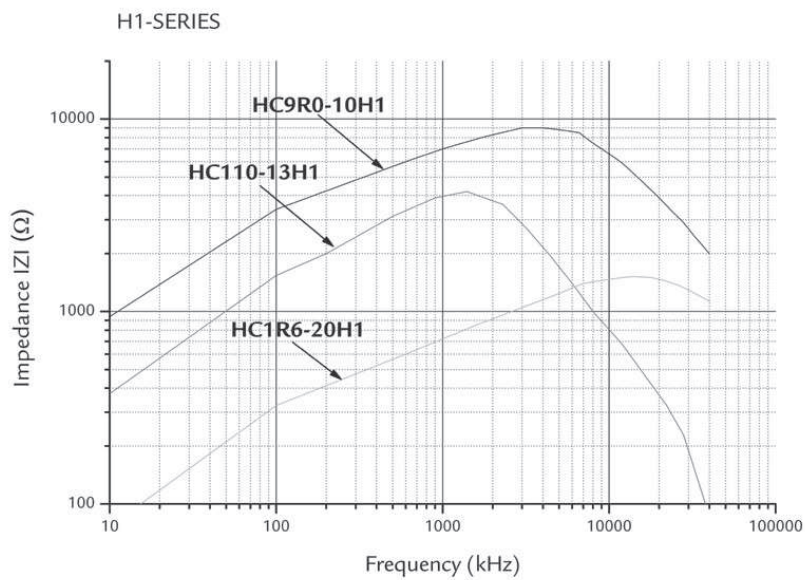
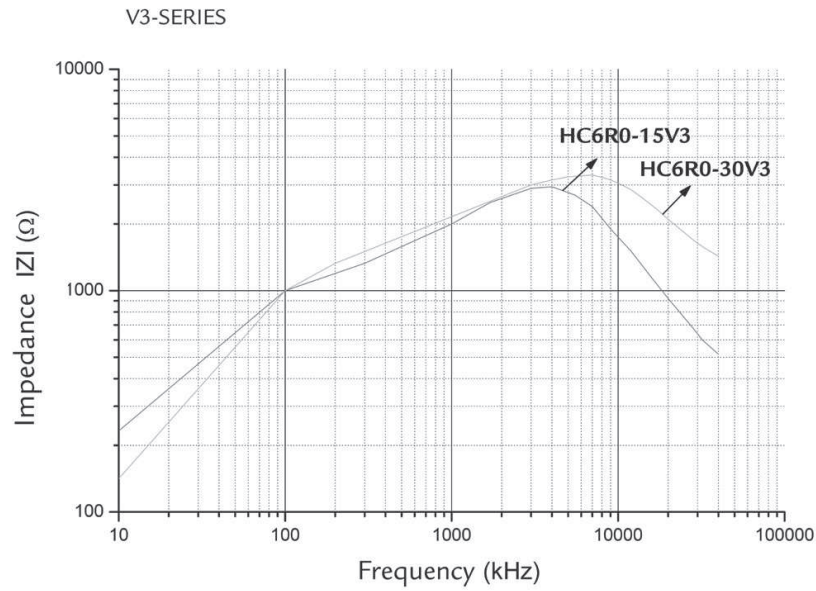

Note:

Impedance measurements have been obtained with both windings in parallel and at ambient temperature.

HC SERIES

Common mode chokes with Nanocrystalline cores

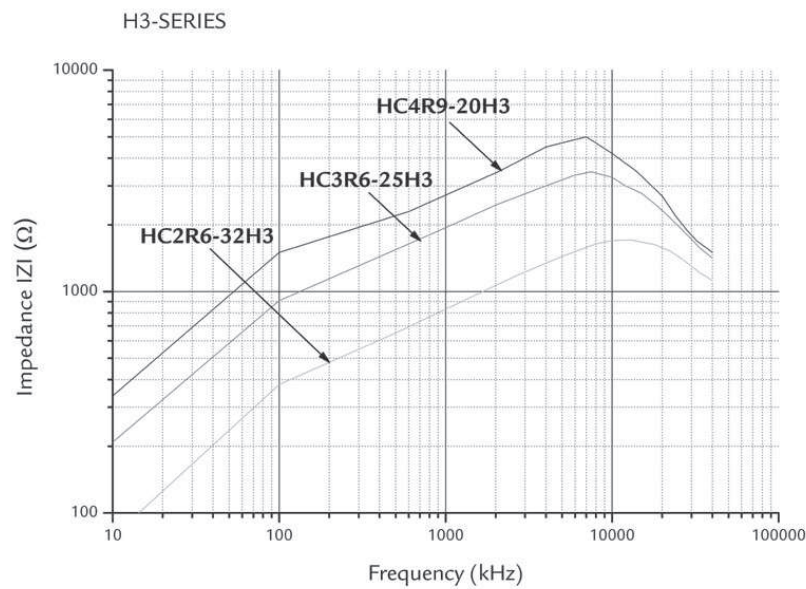
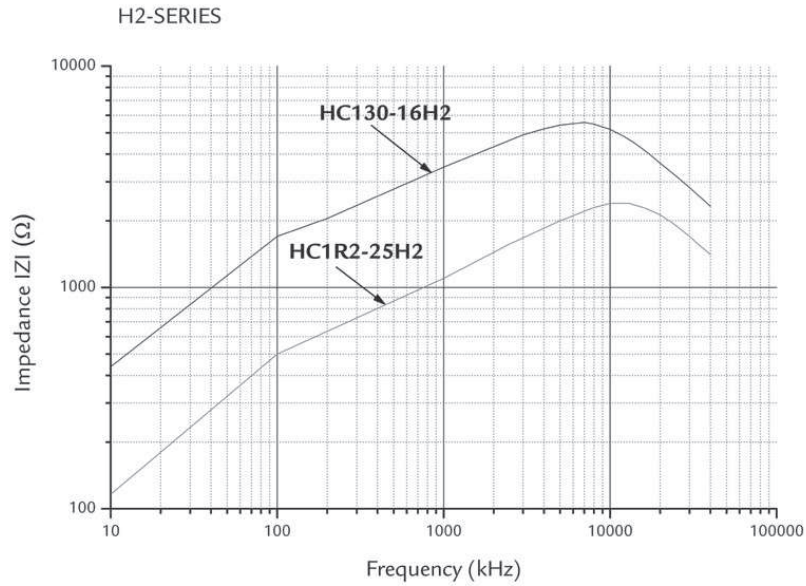

Note:

Impedance measurements have been obtained with both windings in parallel and at ambient temperature.