

FVTO-IV

Three Phase + Neutral Filters, Double Stage

Electrical schematics

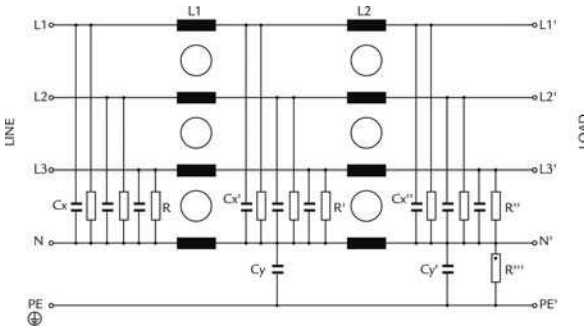

General Specifications

Maximum operating voltage: 520Vac.

Operating frequency: DC - 60Hz.

Hipot test voltage: L/N->PE: 3000Vdc 2s.

L->N: 1300 Vdc 2s.

Li->Lj: 2250 Vdc 2s.

Application class: HPF Acc. TO DIN 40040

(-25°C/+85°C/95% RH, 30d).

Flammability class: UL 94 V2.

Three Phase + Neutral Filters, Double Stage

Three phase + neutral filter for frequency inverters/PDS.

“Foot-print” mounting.

High attenuation properties.

Small and ergonomic size.

FVTO-IV

Three Phase + Neutral Filters, Double Stage

Product List

TYPE	I	L	CX/CX'/CX''	CY/CY'	R/R'	HOUSING	Max. I _{rug} mA IEC 950	Max. I _{rug} mA 400V 50Hz	CONNECTION HxØ M+N
FVTO6IV	6 Amp	5 mH	1 µF	47nF/470nF	/-/680KΩ/680KΩ/1MΩ	406	47,6 mA	4,5 mA	6mm ²
FVTO10IV	10 Amp	5 mH	1 µF	47nF/470nF	680KΩ/680KΩ/-/-	405	47,6 mA	4,5 mA	M4 SCREW
FVTO12IV	12 Amp	5 mH	2,2µF	47nF/470nF	/-/680KΩ/680KΩ/1MΩ	406	51,8 mA	4,7 mA	6mm ²
FVTO20IV	20 Amp	2 mH	2,2µF	47nF/1µF	680KΩ/680KΩ/-/-	409	97,6 mA	9,28 mA	M6 SCREW
FVTO20IVB	20 Amp	2 mH	2,2µF	47nF/1µF	680KΩ/680KΩ/-/-	407	97,6 mA	9,28mA	4mm ²
FVTO30IV	30 Amp	1,2 mH	2,2µF	150nF/220nF	680KΩ/-/-/-	408	37,8 mA	3,4 mA	10mm ²
FVTO40IV	40 Amp	1,2 mH	2,2µF	150nF/220nF	680KΩ/-/-/-	408	37,8 mA	3,4 mA	10mm ²
FVTO60IV	60 Amp	1,5 mH	2,2µF	330nF/2,2µF	680KΩ/-/-/330KΩ	408	187 mA	19,4 mA	10mm ²
FVTO60IVB	63 Amp	1,5 mH	2,2µF	330nF/2,2µF	680KΩ/-/-/330KΩ	411	187 mA	19,4 mA	25mm ²
FVTO80IV	80 Amp	170 µH	2,2µF	150nF/220nF	680KΩ/-/-/-	413	16 mA	1,4 mA	M10 SCREW
FVTO80IVB	80 Amp	170 µH	2,2µF	150nF/220nF	680KΩ/-/-/-	310	16 mA	1,4 mA	25mm ²
FVTO100IV	100 Amp	170 µH	2,2µF	150nF/220nF	680KΩ/-/-/-	413	16 mA	1,4 mA	M10 SCREW
FVTO150IV	150 Amp	160 µH	4,4/4,4/2,2µF	470nF/470nF	/-/1MΩ/330KΩ	413	38,9 mA	3,4 mA	M10 SCREW
FVTO180IV	180 Amp	160 µH	4,4/4,4/2,2µF	100nF/2,2µF	/-/1MΩ/680KΩ	413	190 mA	18,4 mA	M10 SCREW

Insertion Loss

----- ASYM
 ——— SYM

