

CS0805F

Ceramic Chip Inductor 0805 High Q (2.2nH-1000nH)

Features

CS0805 ceramic wound chip inductor is manufactured under 100% test of L and Q actual operating frequencies. Fully automatic machine made, this series issues 0-defects. High Q factor and self-resonance frequencies, allow excellent operation in GSM frequencies, DECT, cordless communications, wireless LANs, etc. High production capacity ensures immediate delivery time.
 Operating temperature: $-40\text{ }^{\circ}\text{C} \rightarrow +125\text{ }^{\circ}\text{C}$.
 Storage temperature: $-40\text{ }^{\circ}\text{C} \rightarrow +125\text{ }^{\circ}\text{C}$.

Materials

0805 type in High alumina ceramic body Al_2O_3 96% .
 Metallization: W + Ni (min $2\mu\text{m}$) + Au flash.

Dimensions

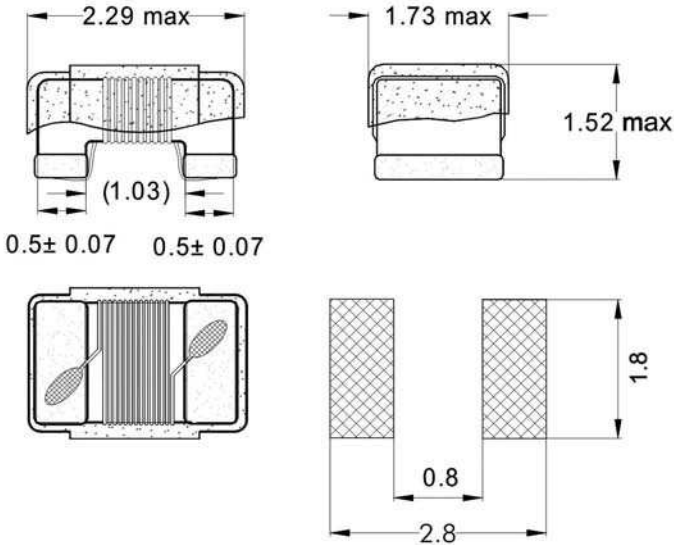

CS0805F

Ceramic Chip Inductor 0805 High Q (2.2nH-1000nH)

Product List

Ordering code ¹	Lr (nH)	Tolerance	Q _{min}	SRF Min. (MHz)	DCR max. (Ω)	I _{rms} (mA)
CS0805F-2R2+	2.2@1000MHz	M,K,J	35 @ 1000 MHz	3000	0.03	600
CS0805F-2R7+	2.7@250MHz	M,K,J	35 @ 1000 MHz	6000	0.03	600
CS0805F-2R8+	2.8@250MHz	M,K,J	80 @ 1500 MHz	7900	0.06	800
CS0805F-2R9+	2.9@250MHz	M,K,J	50 @ 1500 MHz	4700	0.05	600
CS0805F-3R0+	3.0@250MHz	M,K,J	65 @ 1500 MHz	7900	0.06	800
CS0805F-3R3+	3.3@250MHz	M,K,J	50 @ 1500 MHz	7900	0.08	600
CS0805F-5R6+	5.6@250MHz	M,K,J	65 @ 1000 MHz	5500	0.08	600
CS0805F-6R8+	6.8@250MHz	M,K,J	50 @ 1000 MHz	5500	0.11	600
CS0805F-7R5+	7.5@250MHz	M,K,J	50 @ 1000 MHz	4500	0.14	600
CS0805F-8R2+	8.2@250MHz	M,K,J,G	50 @ 1000 MHz	4700	0.12	600
CS0805F-100+	10@250MHz	M,K,J,G	60 @ 500 MHz	4200	0.10	600
CS0805F-110+	11@700MHz	M,K,J,G	45 @ 500 MHz	3000	0.15	600
CS0805F-120+	12@250MHz	M,K,J,G	50 @ 500 MHz	4000	0.15	600
CS0805F-150+	15@250MHz	M,K,J,G	50 @ 500 MHz	3400	0.17	600
CS0805F-180+	18@250MHz	M,K,J,G	50 @ 500 MHz	3300	0.20	600
CS0805F-220+	22@250MHz	M,K,J,G	55 @ 500 MHz	2660	0.22	500
CS0805F-240+	24@250MHz	M,K,J,G	50 @ 250 MHz	2000	0.22	500
CS0805F-270+	27@250MHz	M,K,J,G	55 @ 500 MHz	2500	0.25	500
CS0805F-330+	33@250MHz	M,K,J,G	60 @ 500 MHz	2050	0.27	500
CS0805F-360+	36@250MHz	M,K,J,G	55 @ 500 MHz	1700	0.27	500
CS0805F-370+	37@350MHz	M,K,J,G	40 @ 500 MHz	1800	0.27	500
CS0805F-380+	38@350MHz	M,K,J,G	40 @ 500 MHz	1800	0.27	500
CS0805F-390+	39@250MHz	M,K,J,G	60 @ 500 MHz	2000	0.29	500
CS0805F-430+	43@200MHz	M,K,J,G	60 @ 500 MHz	1650	0.34	500
CS0805F-470+	47@200MHz	M,K,J,G	60 @ 500 MHz	1650	0.31	500
CS0805F-560+	56@200MHz	K,J,G,F	60 @ 500 MHz	1550	0.34	500
CS0805F-680+	68@200MHz	K,J,G,F	60 @ 500 MHz	1450	0.38	500
CS0805F-820+	82@150MHz	K,J,G,F	65 @ 500 MHz	1300	0.42	400
CS0805F-910+	91@150MHz	K,J,G,F	65 @ 500 MHz	1200	0.48	400
CS0805F-101+	100@150MHz	K,J,G,F	65 @ 500 MHz	1200	0.46	400
CS0805F-111+	110@150MHz	K,J,G,F	50 @ 500 MHz	1000	0.48	400
CS0805F-121+	120@150MHz	K,J,G,F	50 @ 250 MHz	1100	0.51	400
CS0805F-151+	150@100MHz	K,J,G,F	50 @ 250 MHz	920	0.56	400
CS0805F-181+	180@100MHz	K,J,G,F	50 @ 250 MHz	870	0.64	400
CS0805F-221+	220@100MHz	K,J,G	50 @ 250 MHz	850	0.70	400
CS0805F-241+	240@100MHz	K,J,G	44 @ 250 MHz	690	1.00	350
CS0805F-271+	270@100MHz	K,J,G	48 @ 250 MHz	650	1.00	350
CS0805F-301+	300@150MHz	K,J,G	25 @ 250 MHz	450	1.40	300
CS0805F-331+	330@100MHz	K,J,G	48 @ 250 MHz	600	1.40	310
CS0805F-361+	360@100MHz	K,J,G	35 @ 250 MHz	460	0.90	300
CS0805F-391+	390@100MHz	K,J,G	48 @ 250 MHz	560	1.50	290
CS0805F-431+	430@100MHz	K,J	25 @ 100 MHz	400	1.70	190
CS0805F-471+	470@50MHz	K,J	33 @ 100 MHz	375	1.76	250
CS0805F-561+	560@25MHz	K,J	23 @ 50 MHz	340	1.90	230
CS0805F-681+	680@25MHz	K,J	23 @ 50 MHz	188	2.20	190
CS0805F-821+	820@25MHz	K,J	23 @ 50MHz	215	2.35	180
CS0805F-911+	910@25MHz	K,J	24 @ 50MHz	250	2.30	170
CS0805F-102+	1000@25MHz	K,J	23 @ 50MHz	260	2.70	170

1 Replace the + by the code letter for the required inductance tolerance (F=1%,G=2%,J=5%,K=10%,M=20%).