

3DC1515

SMD 3D Coil 17.5x15.5x3.8 mm MAX (2.47 mH – 10mH)

Characteristics

- This 3D coil, RFID innovate component, highlights for its high sensitivity, low profile and small size.
- Ensures optimal field sensing regardless position.
- Best choice for Keyless Entry Systems.
- High drop test resistance (up to 500 times 1m) due to a maximized pin area.
- High stability in temperature (-40°C to +85°C).
- Isotropic version available.
- With cover cap or labeled.
- Designed for 125 kHz and 134 kHz.

Dimensions and recommended pad layout

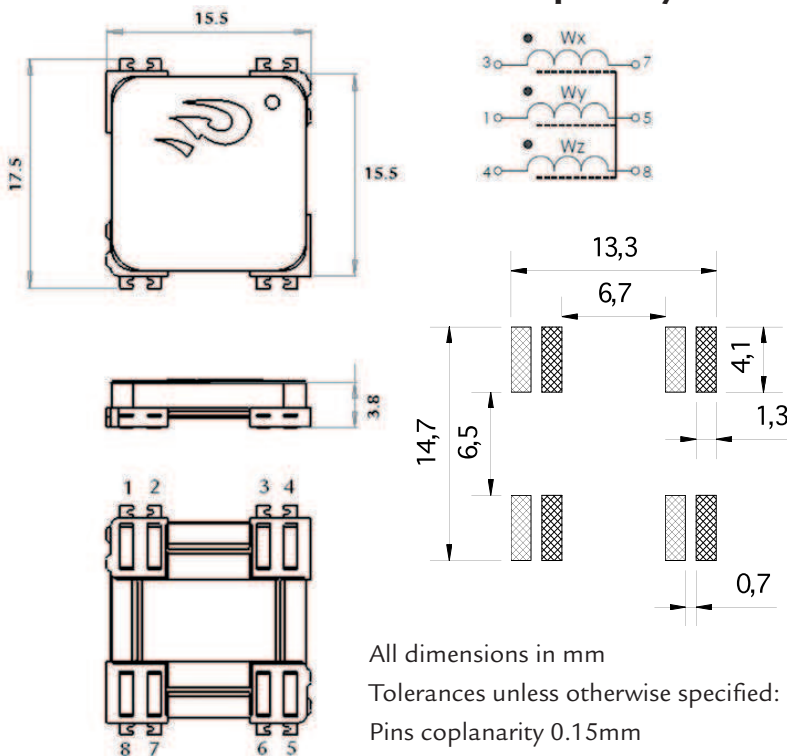

All dimensions in mm

Tolerances unless otherwise specified: ± 0.20 mm

Pins coplanarity 0.15mm

Main applications

Automotive.

- Passive keyless entry and Keyless Go systems.
 - TPMS with wake up functions.
- Industrial.
- Access control.
 - Tracking devices.

Electrical specifications

P/N	L x,y,z (mH)	Cres (pF)	Qx,y typ	SRFx,y (KHz) min	SRFz(KHz) min	RDC max x,y (Ω)	RDC max z(Ω)	Sensitivity x,y,z (mVpp/App/m)
3DC15-0247J	2.47	656	>23	>500	>1000	75	75	>55
3DC15-0258J	2.58	628	>23	>500	>800	75	75	>57
3DC15-0345J	3.45	470	>27	>450	>800	85	100	>67
3DC15-0405J	4.05	400	>27	>400	>800	98	98	>72
3DC15-0477J	4.77	340	>28	>380	>800	100	136	>85
3DC15-0491J	4.91	330	>27	>350	>750	105	140	>85
3DC15-0720J	7.20	225	>30	>330	>700	120	172	>95
3DC15-1000J	10.00	162	>25	>250	>550	165	258	>105

This chart is a reference guide for the most common required values at working frequency of 125 kHz. Any other inductance value at LF or tighter tolerances can be provided. Also can be supplied different inductance values in the different winding axis. Please contact our sales department for any inquiry.

L and Q factor measured at 125 kHz, 1 Vac.

Sensitivity measured with Helmholtz coils $H=1.27$ App/m @125 kHz. Contact us for measurement specification.

SRF: Self Resonant Frequency of the coil.