

Performance Specifications

Table 1. Electrical Performance

Parameter	Symbol	Min	Typical	Maximum	Units
Frequency ⁴					
Input Frequency	F_{IN}	0.001		77.76	MHz
Output Frequency	F_{OUT}	0.1		80.0	MHz
Capture Range (ordering option)	APR	±50, ±80, or ±100			ppm
Supply Voltage ¹ (V_{DD} , V_{DB} , V_{DA} , V_{DO})	V_{DD}	4.5	5.0	5.5	V
	V_{DD}	2.97	3.3	3.63	V
Current ⁵	I_{DD}			40	mA
Input					
Input High Voltage	V_{IH}	$0.7*V_{DD}$			V
Input Low Voltage	V_{IL}			$0.3*V_{DD}$	V
Output					
Output High Voltage	V_{OH}	$0.9*V_{DD}$			V
Output Low Voltage	V_{OL}			$0.1*V_{DD}$	V
Output					
Rise Time ²	t_R			3.0	ns
Fall Time ²	t_F			3.0	ns
Duty Cycle ³	SYM	40	50	60	%
Jitter Generation - 80.0MHz output	Φ_J		4.7		ps-rms
Operating Temp (ordering option)	T_{OP}	0/70, -40/85			°C

1. A 0.01uF high frequency ceramic capacitor in parallel with a 0.1uF low frequency tantalum bypass capacitor is recommended
2. Figure 2 defines the waveform parameters. Figure 3 illustrates the standard test conditions under which these parameters are tested and specified.
3. Duty Cycle is defined as (on time/period) with $V_s = V_{DD}/2$ per Figure 2. Duty Cycle is measured with a 15pf load per Figure 3.
4. Other frequencies may be available, please contact factory.
5. Combined Current From VDD, VDO, VDA, and VDB

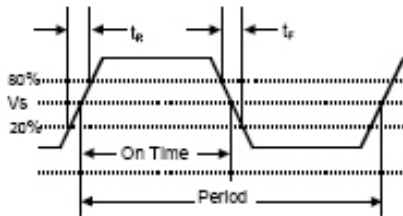

Figure 2. Output Waveform

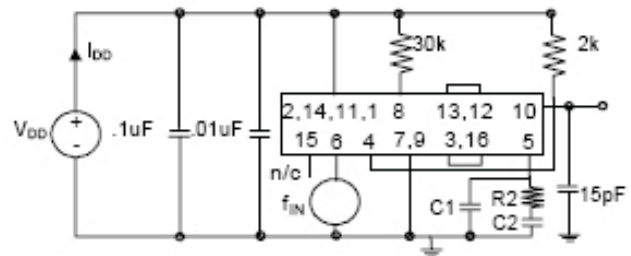

Figure 3. Output Test Conditions (25°C ±5°C)

Absolute Maximum Ratings

Stresses in excess of the absolute maximum ratings can permanently damage the device. Functional operation is not implied at these or any other conditions in excess of conditions represented in the operational sections of this data sheet. Exposure to absolute maximum ratings for extended periods may adversely affect device reliability.

Table 2. Absolute Maximum Ratings

Parameter	Symbol	Ratings	Unit
Power Supply	V_{DD}	7	V
Storage Temperature	T_{STR}	-55 to 125	°C

Reliability

The FX-700 is capable of meeting the following qualification tests

Table 3. Environmental Compliance	
Parameter	Conditions
Mechanical Shock	MIL-STD-883, Method 2002
Mechanical Vibration	MIL-STD-883, Method 2007
Solderability	MIL-STD-883, Method 2003
Gross and Fine Leak	MIL-STD-883, Method 1014
Resistance to Solvents	MIL-STD-883, Method 2016

Handling Precautions

Although ESD protection circuitry has been designed into the the FX-700, proper precautions should be taken when handling and mounting. VI employs a human body model and a charged-device model (CDM) for ESD susceptibility testing and design protection evaluation. ESD thresholds are dependent on the circuit parameters used to define the model. Although no industry wide standard has been adopted for the CDM, a standard HBM of resistance=1.5Kohms and capacitance = 100pF is widely used and therefore can be used for comparison purposes

Table 4. Predicted ESD Ratings		
Model	Minimum	Conditions
Human Body Model	1500 V	MIL-STD 883, Method 3015
Charged Device Model	1000 V	JEDEC, JESD22-C101

Solder Reflow Profile

Table 5. Reflow Profile (IPC/JEDEC J-STD-020C)		
Parameter	Symbol	Value
PreHeat Time	t_s	60 sec Min, 180 sec Max
Ramp Up	R_{UP}	3 °C/sec Max
Time Above 217 °C	t_L	60 sec Min, 150 sec Max
Time To Peak Temperature	t_{AMB-P}	480 sec Max
Time At 260 °C	t_p	20 sec Min, 40 sec Max
Ramp Down	R_{DN}	6 °C/sec Max

The device has been qualified to meet the JEDEC standard for Pb-Free assembly. The temperatures and time intervals listed are based on the Pb-Free small body requirements. The temperatures refer to the topside of the package, measured on the package body surface. The FX-700 device is hermetically sealed so an aqueous wash is not an issue.

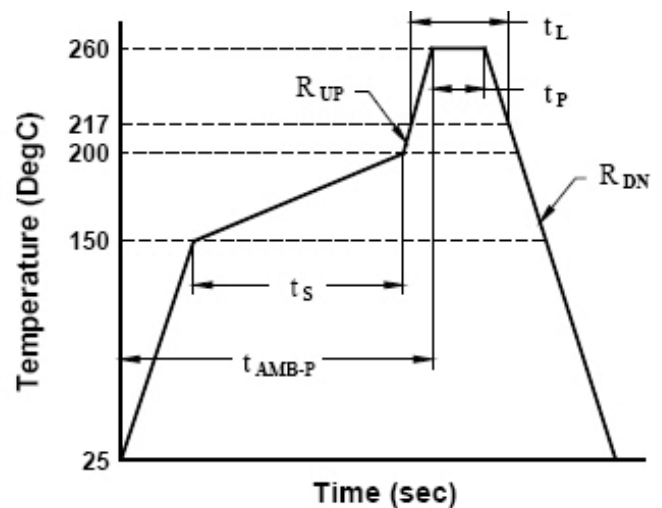

Figure 3. Suggested IR Profile

Dimensions in mm.

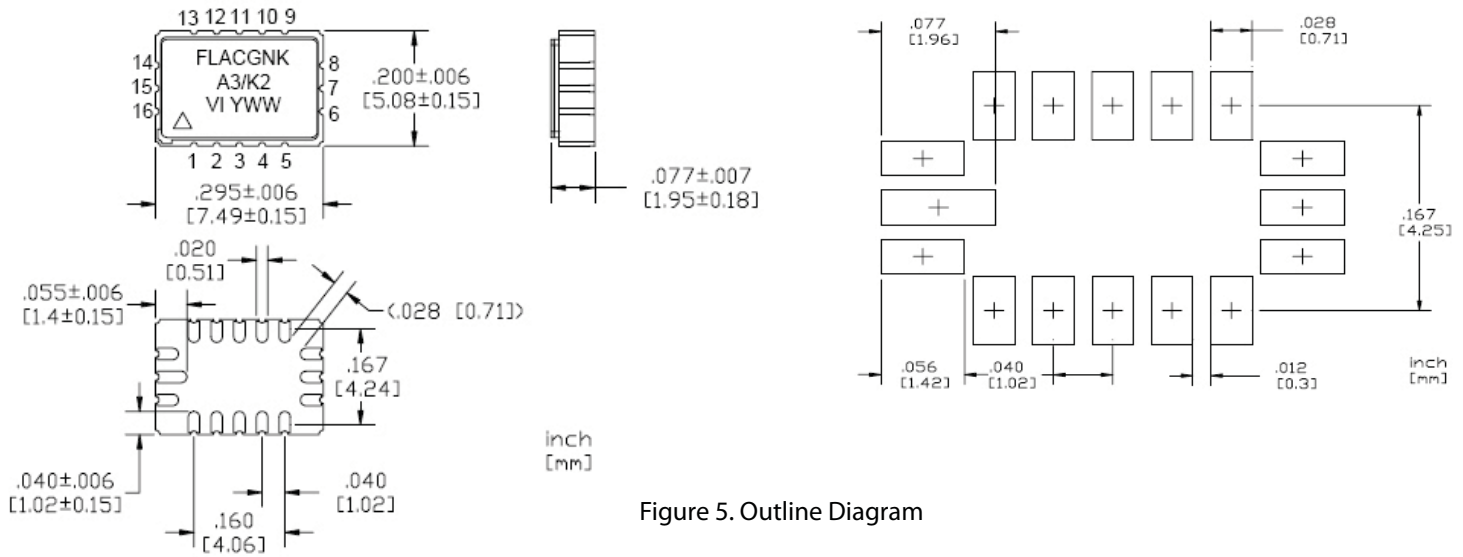

Figure 5. Outline Diagram

Table 7. Pin Functions		
Pad #	Symbol	Function
1	V _{DD}	Digital PLL Supply (3.3 V +/- 10% or 5.0 V +/- 10%)
2	V _{DA}	Analog PLL Supply (3.3 V +/- 10% or 5.0 V +/- 10%)
3	V _{COU} T	Control Voltage
4	Tri-state ¹	Logic Low = Output Disable / Logic High = Output Enabled
5	C1	Passive Loop Filter Node
6	FIN	Input Frequency
7	GND	Cover and Electrical Ground
8	LD ²	Lock Detect
9	GNDB	Output Buffer Ground
10	FOU	Output Frequency
11	VDB	Output Buffer Supply (3.3 V +/- 10% or 5.0 V +/- 10%)
12	VCXO _{IN}	VCXO Input
13	VCXO _{OUT}	VCXO Output
14	V _{DO}	VCXO Supply (3.3 V +/- 10% or 5.0 V +/- 10%)
15	N.C.	No Internal Connection Made
16	V _{CIN}	VCXO Control Voltage Input

1 Tri-state must be driven to a logic high or a logic low, there is no internal pull up or pull down resistor (tie pin to VDD for PLL operation).
 2 LD is an open collector output requiring a 30k ohm minimum pull-up resistor to VDD. LD output is logic high under locked condition, logic low for no input at FIN, and for "out-of-lock" condition LD transitions between logic low and high at the phase detector frequency.

Tape and Reel

Table 6. Tape and Reel Information

Tape Dimensions (mm)					Reel Dimensions (mm)							
A	B	C	D	E	F	G	H	I	J	K	L	#/Reel
16	7.5	1.5	4	8	1.5	20.2	13	50	6	16.4	178	500

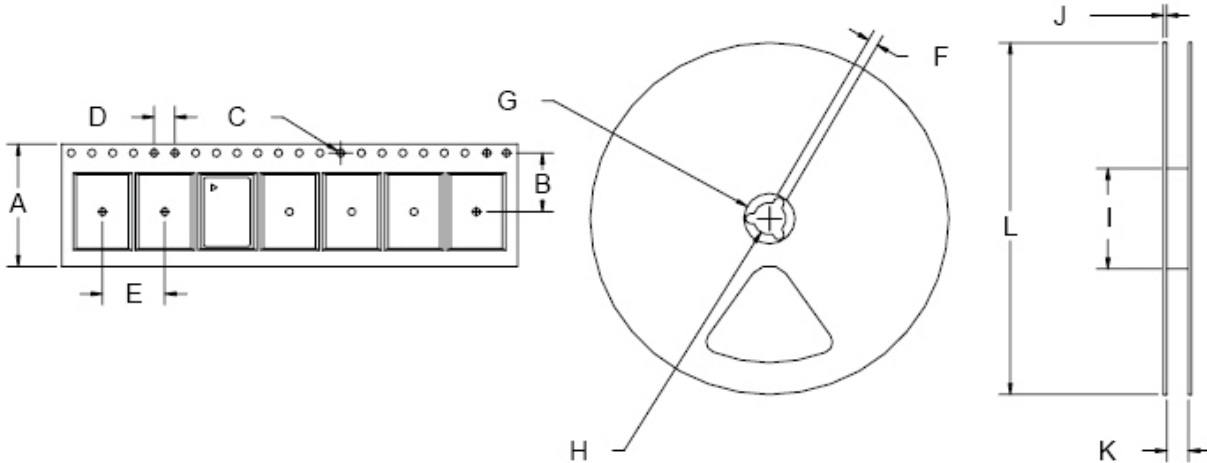

Figure 4. Tape and Reel

FX-700 Theory of Operation

The FX-700 includes an integrated phase detector, current mode charge pump, programmable frequency dividers and VCXO. The FX-700 will translate an input frequency such as 8 kHz, 1.544 MHz or 19.440 MHz to a specific output frequency which is an integer multiple (1-16384) of the input frequency and less than or equal to 77.760 MHz. For clock smoothing applications, the input frequency is typically internally divided down by a factor of 64 (2N where N = 6) by the input frequency divider and this frequency becomes an input to the phase detector. The integrated frequency dividers (factory programmed) and crystal based VCXO allows for a large range of possible frequency translations and clock smoothing applications.

The FX-700's PLL is a feedback system which forces the output frequency to lock in both phase and frequency to the input frequency. While there will be some phase error, theory states there is no frequency error. The loop filter design will dictate many key parameters such as jitter reduction, stability, lock range and acquisition time. The external second order passive loop filter is a complex impedance in parallel with the input capacitance of the VCXO. The loop filter converts the charge pump output into the VCXO's control voltage. VI's loop filter design methodology involves the calculation of the open loop gain bandwidth and corresponding phase margin to determine the optimal component values that ensure high loop stability and acceptable lock in time. As a rule of thumb, the VCXO gain is typically 100 ppm/volt and the charge pump current is typically 32 uA.

VI's Applications Engineering staff can provide the external loop filter component values required to meet specific system requirements and application.

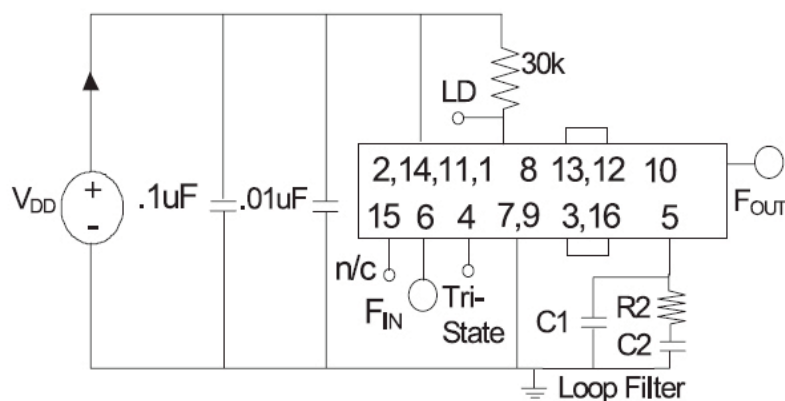

Suggested FX-700 Circuit Configuration Drawing

Table 7. Standard Frequencies

0.01000000	A1	0.25600000	AM	2.55750000	B9	10.23000000	DP	19.3926580	DX	25.60000000	F6	39.8437500	HJ	50.00000000	JD	74.1758000	KA
0.00200000	AR	0.32000000	AW	3.08800000	B6	10.24000000	DM	19.44000000	D6	25.92000000	F2	40.00000000	JF	50.04800000	KD	74.25000000	K7
0.00320000	AG	0.38400000	AY	3.24000000	BL	10.4142850	DV	19.5312500	DZ	26.00000000	F3	40.2830630	KK	51.20000000	LL	75.00000000	KH
0.00400000	A2	0.40000000	AF	3.25000000	BC	10.4582260	DU	19.6608000	DB	27.00000000	F4	40.96000000	J1	51.84000000	J4	76.80000000	K4
0.00800000	A3	0.48000000	AK	3.37500000	BH	10.4872000	DN	19.6989680	DK	27.64800000	FB	41.0888870	KM	52.00000000	JP	77.76000000	K2
0.00819200	BY	0.50000000	BP	3.84000000	B7	10.9490000	DG	19.7190000	DH	28.70400000	F1	41.6571440	KP	53.33000000	JU		
0.00946900	AU	0.51200000	AJ	4.00000000	BN	10.95000000	DJ	19.9218750	ED	29.49120000	F5	41.66000000	LM	54.74600000	JL		
0.01000000	A6	0.65545000	AE	4.09600000	B5	11.1840000	DF	20.00000000	E2	29.50000000	F9	41.8329130	KT	55.00000000	JX		
0.01562500	AL	0.77200000	AT	4.19430400	CJ	12.2880000	D8	20.1416000	E3	30.00000000	HE	42.00000000	JB	60.00000000	JR		
0.01573400	AD	0.96000000	A7	5.00000000	C6	12.3076860	DY	20.48000000	E4	30.72000000	H1	42.0101690	KV	61.38000000	KY		
0.01575000	AC	1.00000000	BB	5.12000000	CD	12.3520000	D1	20.5444340	EF	30.88000000	HF	42.50000000	JC	61.44000000	J5		
0.01600000	A4	1.02400000	B2	6.14400000	CG	12.80000000	D2	20.7135000	E1	31.25000000	H8	42.66000000	JZ	62.20800000	J8		
0.02400000	BX	1.21500000	BU	6.29140000	CC	13.00000000	D3	20.8285720	EG	32.00000000	H2	44.2095440	KX	62.50000000	J9		
0.02500000	BR	1.22880000	BK	6.29145600	CF	13.50000000	DT	20.8286000	EB	32.76800000	H3	44.4343000	LF	62.91450000	LE		
0.03200000	BW	1.25000000	BG	6.31200000	C7	14.8351600	DL	20.9165460	EH	33.00000000	H7	44.6218000	JW	63.36000000	JJ		
0.04000000	AP	1.33330000	BF	6.48000000	C2	15.00000000	D4	21.0050840	EJ	33.33330000	HC	44.73600000	J3	63.89760000	JN		
0.04410000	AA	1.50000000	BE	6.75000000	CB	15.0336000	DR	22.00000000	E9	34.36800000	H6	44.9280000	JE	64.00000000	JT		
0.04800000	AB	1.53600000	BV	7.68000000	C9	15.36000000	DW	22.1047720	EK	34.56000000	HB	45.1584000	JG	64.15200000	JH		
0.04807700	AV	1.54400000	B3	7.77600000	C5	16.00000000	D9	22.2171000	E5	36.86400000	HG	45.8240000	JM	65.53600000	J6		
0.05000000	BT	1.92000000	B1	8.19200000	C3	16.3840000	D5	22.5792000	E8	37.05600000	H4	46.0379460	LG	66.00000000	JA		
0.06400000	A5	2.00000000	B8	9.21600000	CH	17.1840000	DE	24.00000000	EC	37.12500000	H9	46.7200000	JK	70.00000000	KB		
0.08000000	A9	2.04800000	B4	9.72000000	C8	18.4320000	D7	24.5760000	E6	37.50000000	HK	46.8750000	JY	70.65600000	KC		
0.10000000	AH	2.30400000	BD	9.75000000	CE	18.5280000	DC	24.7040000	E7	38.88000000	H5	48.00000000	JV	71.61000000	KF		
0.12800000	AX	2.45760000	BJ	9.83040000	C1	18.75000000	EE	25.00000000	F7	39.06250000	HH	49.1520000	J7	73.72800000	K8		
0.24300000	A8	2.50000000	BM	10.00000000	C4	19.20000000	DD	25.1658000	F8	39.32160000	HD	49.4080000	J2	74.12500000	K1		

Ordering Information

FX-700-E A E-K N K N-XX-XX

Product Family

FX: Frequency Translator

Package

700: 5.0 x 7.5 x 2.0mm

Input

D: 5.0 Vdc \pm 10%

E: 3.3 Vdc \pm 10%

Output

A: CMOS

Operating Temperature

E: -40 to 85 °C

T: 0 to 70 °C

Absolute Pull Range

K: \pm 50 ppm

P: \pm 80 ppm

S: \pm 100 ppm

Output Frequency
(See Above)

Input Frequency
(See Above)

Performance Options

N: Standard

A: Improved Phase Noise

Loop Filter BW

K: External Loop Filter

Factory Use

Note: Not all combinations will be available - check with the factory to determine the optimum configuration for your application

For Additional Information, Please Contact

USA:

Vectron International
267 Lowell Road
Hudson, NH 03051
Tel: 1.888.328.7661
Fax: 1.888.329.8328

Europe:

Vectron International
Landstrasse, D-74924
Neckarbischofsheim, Germany
Tel: +49 (0) 3328.4784.17
Fax: +49 (0) 3328.4784.30

Asia:

Vectron International
1F-2F, No 8 Workshop, No 308 Fenju Road
WaiGaoQiao Free Trade Zone
Pudong, Shanghai, China 200131
Tel: 86.21.5048.0777
Fax: 86.21.5048.1881

Disclaimer

Vectron International reserves the right to make changes to the product(s) and or information contained herein without notice. No liability is assumed as a result of their use or application. No rights under any patent accompany the sale of any such product(s) or information.