

SWITCHING TYPE POWER SUPPLY APPLICATIONS.

FEATURES

- Low Profile Surface Mount Package.
- Low Power Loss, High Efficiency.
- For Use in Low Voltage, High Frequency inverters, Free Wheeling, and Polarity Protection Applications.

APPLICATION

- Switching Power Supply.
- DC/DC Converter.
- Home Appliances, Office Equipment.
- Telecommunication.

MAXIMUM RATING (Ta=25 °C)

CHARACTERISTIC	SYMBOL	RATING	UNIT
Maximum Repetitive Peak Reverse Voltage	V_{RRM}	60	V
Average Output Rectified Current	I_O	3	A
Peak One Cycle Surge Forward Current (Non-Repetitive 60Hz)	I_{FSM}	100	A
Junction Temperature	T_j	-40 ~ 150	°C
Storage Temperature Range	T_{stg}	-40 ~ 150	°C

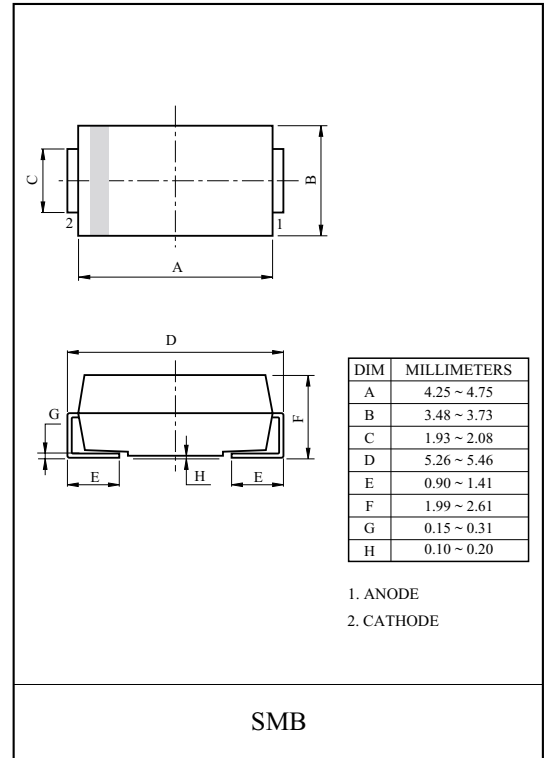

Marking

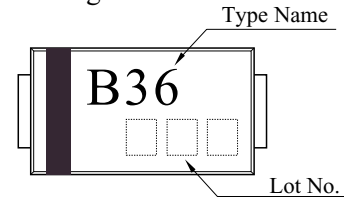

ELECTRICAL CHARACTERISTICS (Ta=25 °C)

CHARACTERISTIC	SYMBOL	TEST CONDITION	MIN.	TYP.	MAX.	UNIT
Peak Forward Voltage	V_{FM}	$I_{FM}=3.0A$	-	-	0.65	V
Repetitive Peak Reverse Current	I_{RRM}	V_{RRM} =Rated, $T_j=25\text{ °C}$	-	-	0.1	mA
		V_{RRM} =Rated, $T_j=100\text{ °C}$	-	-	10	mA
Total Capacitance	C_T	$V_R=4V, f=1MHz$	-	-	250	pF
Thermal Resistance	$R_{th(j-l)}$	Junction to lead	-	-	15	°C/W

SMBB36

$I_F - V_F$

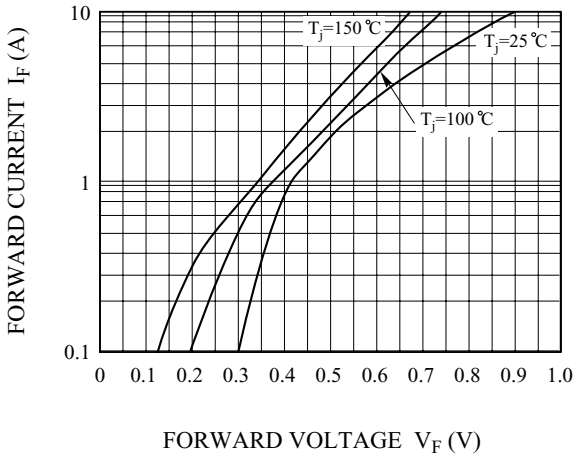

$P_F - I_F$

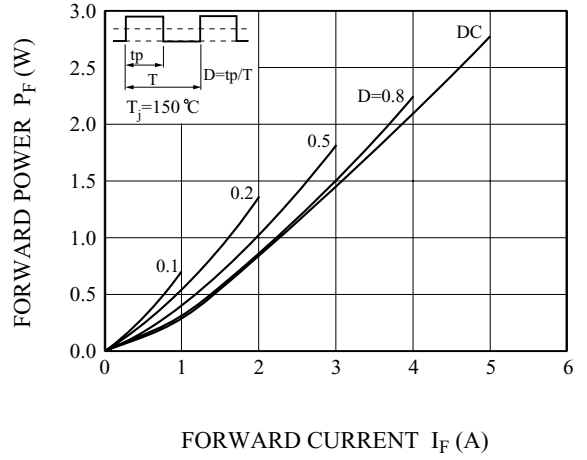

SURGE FORWARD CURRENT (NON - REPETITIVE)

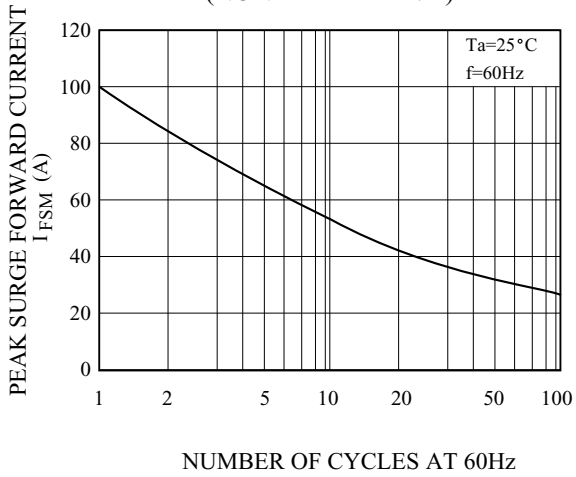

$T_l - I_F$

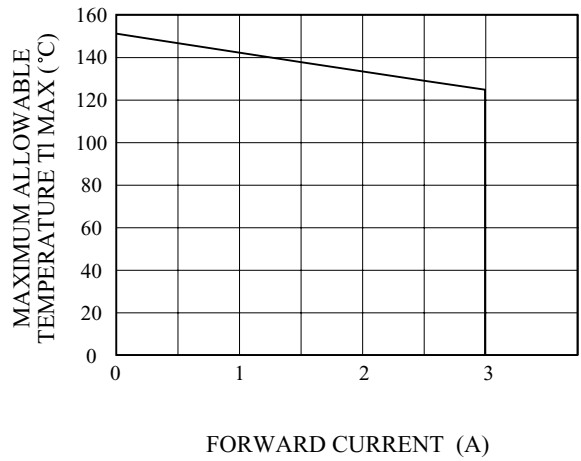

$I_R - V_R$

