

Helping Customers Innovate, Improve & Grow



FX-703

Description

The FX-703 is a low jitter precision frequency translator used to translate input frequencies such as 19.44, 38.88, 77.76 MHz, etc. to a binary multiple frequency as high as 1 GHz. The FX-703's superior jitter performance is achieved through the PLL's integrated VCSO. The FX-703 is housed in a hermetically sealed leadless surface mount package offered on tape and reel.

Features

- 5 x 7.5 x 2.5 mm Package
- Frequency Translation up to 1 GHz
- VCSO based PLL for Ultra-Low Jitter
- Low Power Consumption
- Differential LVPECL Output
- Clock Bypass Mode
- CMOS Lock Detect
- -40°/+85°C Temperature Range
- Complete Easy to Implement Solution
- Fully Compatible for Lead Free Assembly



Applications

- SONET/SDH
- 10GbE./10.3GbE
- Frequency Translation
- Clock Smoothing, Clock Switching
- FEC Scaling
- Medical Instrumentation
- Test and Measurement
- Military

Block Diagram

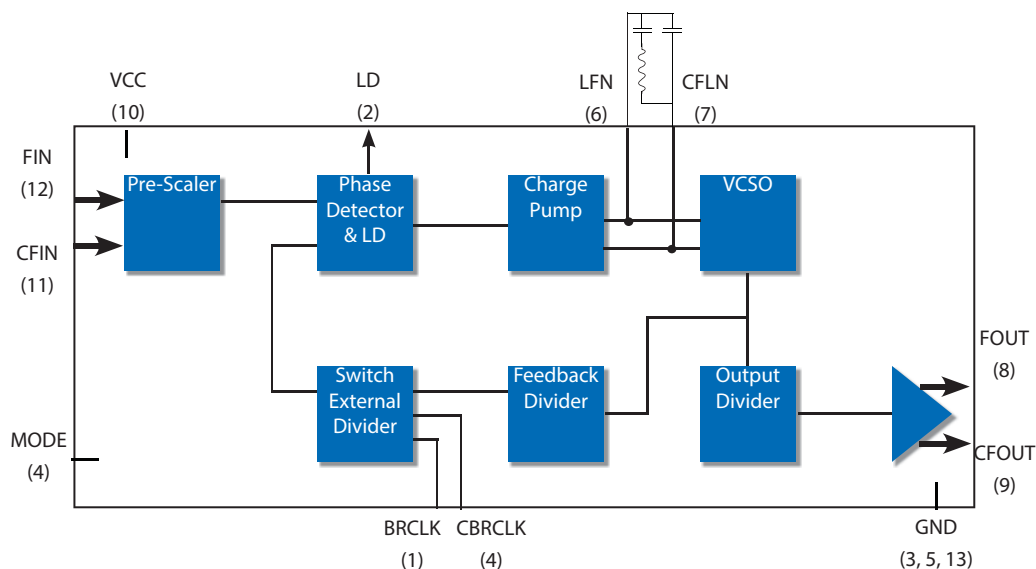

Figure 1. Functional block diagram

Performance Specifications

Table 1. Electrical Performance					
Parameter	Symbol	Min	Typical	Maximum	Units
Frequency ^{1,2,3}					
Input Frequency	F_{IN}	1		1000	MHz
Output Frequency	F_{OUT}	62.5		1000	MHz
Capture Range (ordering option) ^{1,2,3}	APR	$\pm 20, \pm 32, \pm 50, \text{ or } \pm 100\text{ppm}$			ppm
Supply Voltage ^{2,3}	V_{CC}	2.97	3.3	3.63	V
Current (No Load) ³	I_{CC}			125	mA
LVC MOS Input ^{2,3,7}					
Input High Voltage	V_{IH}	2.0		V_{CC}	V
Input Low Voltage	V_{IL}	0		0.8	V
LVPECL Input					
Peal-Peak Amplitude Swing ^{6,7}		0.20		3.00	V
Input Jitter Tolerance				1.0	ns
Lock Detect Output					
Output High Voltage	V_{OH}	$0.9 * V_{CC}$			V
Logic Low Voltage	V_{OL}			$0.1 * V_{CC}$	V
Outputs					
Mid Level - LVPECL ^{2,3}		$V_{CC} - 1.5$	$V_{CC} - 1.3$	$V_{CC} - 1.1$	V
Single Ended Swing - LVPECL ^{2,3}		450	750	1050	mV-pp
Differential Swing - LVPECL ^{2,3}		900	1500	2100	mV-pp
Mid Level - LVDS ^{2,3}		$V_{CC} - 1.4$	$V_{CC} - 1.6$	$V_{CC} - 1.8$	V
Differential Swing - LVDS ^{2,3}		300	450	600	mV-pp
Current ⁵	I_{OUT}			20	mA
Rise Time ^{4,5}	t_R	160		400	ps
Fall Time ^{4,5}	t_F	160		400	ps
Symmetry ^{2,3}	SYM	45	50	55	%
Jitter Generation - 622.08MHz Output (12kHz-20MHz BW) ⁵	Φ_J		210	500	fs-rms
(50kHz - 80MHz BW) ⁵	Φ_J		120	400	fs-rms
Operating Temp (ordering option) ^{1,3}	T_{OP}	0/70, -40/85			°C

1. See Standard Frequencies and Ordering Information.
2. Parameters are tested with production test circuit below (Fig 2).
3. Parameters are tested at ambient temperature with test limits guard banded for specified operating temperature.
4. Measured from 20% to 80% of a full output swing (Fig 3).
5. Not tested in production, guaranteed by design, verified at qualification.
6. Minimum Input Low Voltage not to exceed 2.125 V. Minimum Input High Voltage not to go below 1.49 V.
7. AC coupling is recommended. There is an internal pull-up and pull-down resistor on all clock inputs (Fin, BRCLK).

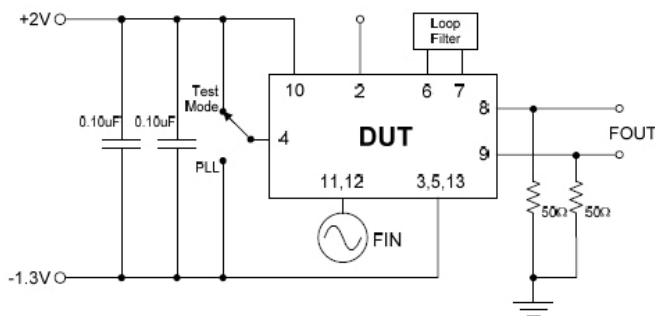

Figure 2. LVPECL Test Circuit

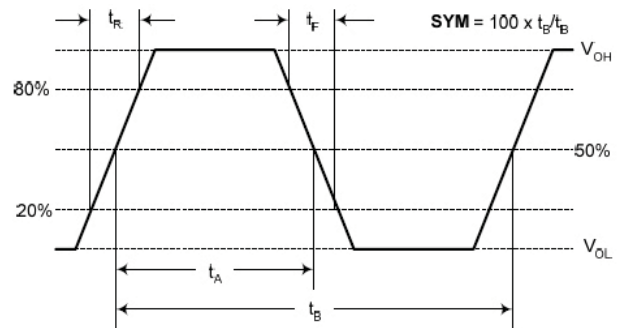

Figure 3. 10K LVPECL Waveform

Absolute Maximum Ratings

Stresses in excess of the absolute maximum ratings can permanently damage the device. Functional operation is not implied at these or any other conditions in excess of conditions represented in the operational sections of this data sheet. Exposure to absolute maximum ratings for extended periods may adversely affect device reliability.

Table 2. Absolute Maximum Ratings

Parameter	Symbol	Ratings	Unit
Power Supply	V_{CC}	0 to 6	V
Input Current	I_{IN}	100	mA
Output Current	I_{OUT}	25	mA
Storage Temperature	T_{STR}	-55 to 125	°C
Soldering Temperature/Duration	T_{PEAK}/t_P	260 / 40	°C/sec

Reliability

The FX-703 is capable of meeting the following qualification tests:

Table 3. Environmental Compliance

Parameter	Conditions
Mechanical Shock	MIL-STD-883, Method 2002
Mechanical Vibration	MIL-STD-883, Method 2007
Solderability	MIL-STD-883, Method 2003
Gross and Fine Leak	MIL-STD-883, Method 1014
Resistance to Solvents	MIL-STD-883, Method 2016
Moisture Sensitivity Level Rating	MSL 1

Handling Precautions

Although ESD protection circuitry has been designed into the the FX-703, proper precautions should be taken when handling and mounting. VI employs a Human Body Model (HBM) and a Charged Device Model (CDM) for ESD susceptibility testing and design protection evaluation. ESD thresholds are dependent on the circuit parameters used to define the model.

Table 4. Predicted ESD Ratings

Model	Class	Minimum	Conditions
Human Body Model	2	2000 V	MIL-STD 883, Method 3015
Charged Device Model	C5	1000 V	JEDEC, JESD22-C101
Machine Model	M3	200 V	ESD STM5.2-1999

Table 5. Reflow Profile (IPC/JEDEC J-STD-020C)

Parameter	Symbol	Value
PreHeat Time	t_s	60 sec Min, 180 sec Max
Ramp Up	R_{UP}	3 °C/sec Max
Time Above 217 °C	t_L	60 sec Min, 150 sec Max
Time To Peak Temperature	t_{AMB-P}	480 sec Max
Time At 260 °C	t_p	20 sec Min, 40 sec Max
Ramp Down	R_{DN}	6 °C/sec Max

The device has been qualified to meet the JEDEC standard for Pb-Free assembly. The temperatures and time intervals listed are based on the Pb-Free small body requirements. The temperatures refer to the topside of the package, measured on the package body surface. The FX-703 device is hermetically sealed so an aqueous wash is not an issue.

Terminal Plating: Electroless Au > 1.50 µm over
Electroless Ni > 1.50 µm

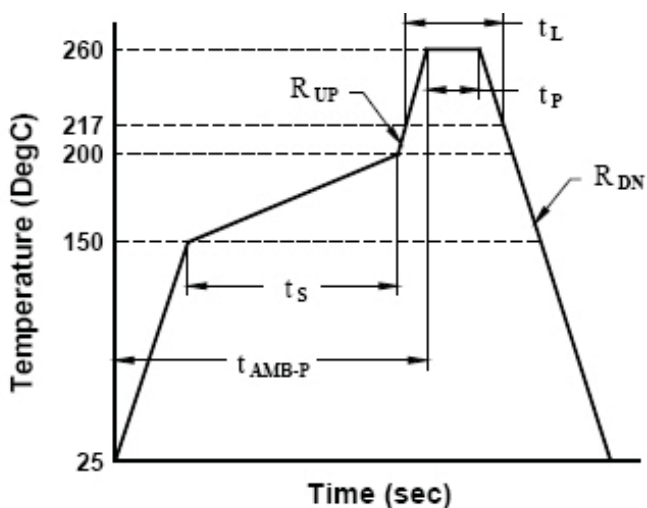

Figure 4. Suggested IR Profile

Table 6. Tape and Reel Information

Tape Dimensions (mm)					Reel Dimensions (mm)							
W	F	Do	Po	P1	A	B	C	D	N	W1	W2	#/Reel
16	7.5	1.5	4	8	178	1.5	13	20.2	50	16.4	22.4	200

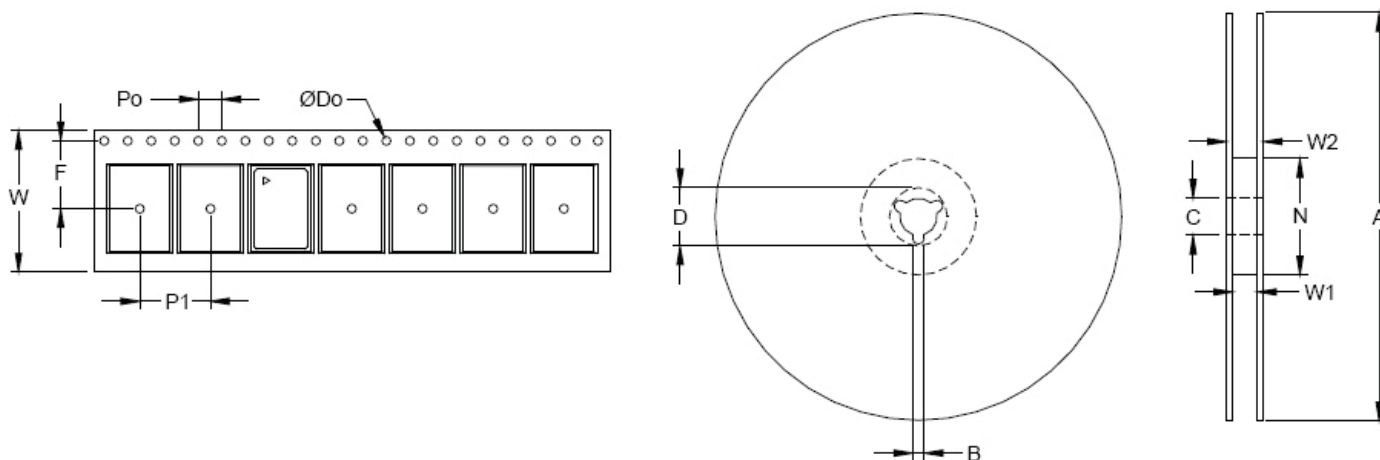

Figure 5. Tape and Reel

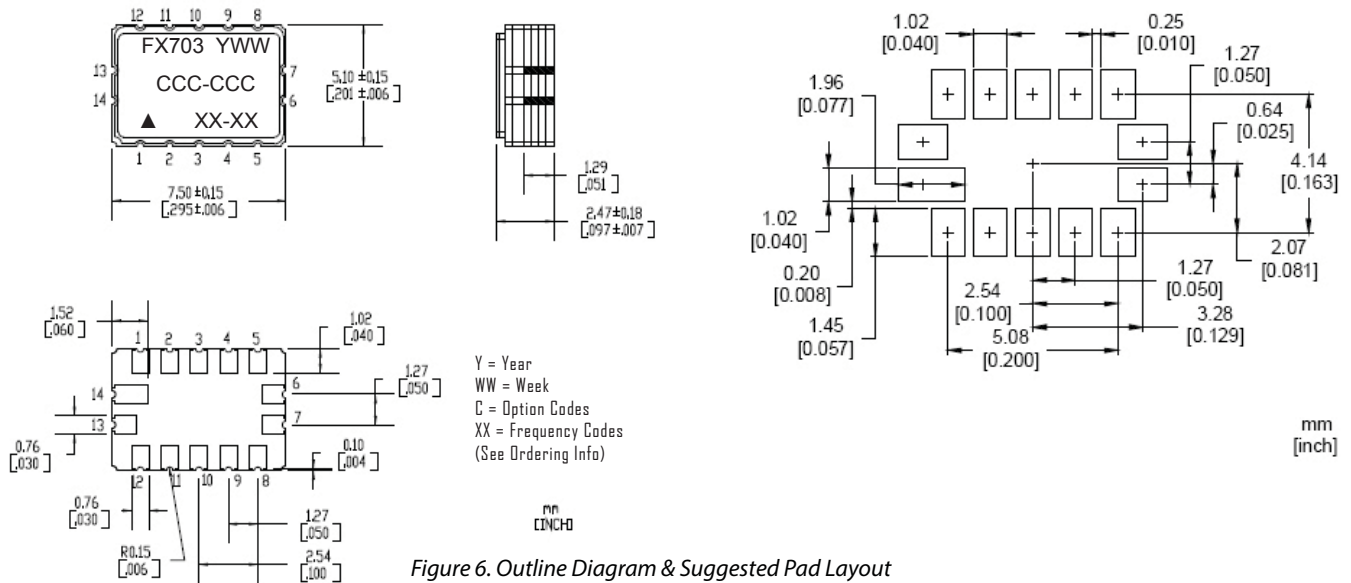

Figure 6. Outline Diagram & Suggested Pad Layout

Table 7. Pin Functions				
Pad #	Symbol	I/O	Level	Function
1	BRCLK	I	NC or LVPECL, LVDS	NC or For External divider application = PD Feedback Frequency
2	LD ¹	O	CMOS	Lock Detect Logic 0 = FX Locked Logic 1 - No Input Output transitioning = Out of Lock
3	GND	GND	Supply	Case and electrical ground
4	MODE ²	I	CMOS	FX Operating Mode Logic 0 = Standard PLL (Normal Setting) Logic 1 = FIN coupled to FOUT
5	GND	GND	Supply	Case and electrical ground
6	LFN		Analog	Loop Filter Node
7	CLFN		Analog	Complementary Loop Filter Node
8	FOUT	O	LVPECL or LVDS	Frequency Output
9	CFOUT	O	LVPECL or LVDS	Complementary Frequency Output
10	VCC	I	Supply	Power Supply Voltage (+3.3V ±5%)
11	CFIN ^{4,5}	I	LVPECL	Complementary Input Frequency For CMOS inouts, AC-couple unused input to ground or negative supply
12	FIN ^{4,5}	I	CMOS or LVPECL	Input Frequency
13	GND	GND	Supply	Case and electrical ground
14	CBRCLK ^{3,4}	I	NC or LVPECL, LVDS	NC or For External divider applications = Comp. PD Feedback Frequency

1. It is recommended that the Lock Detect circuit shown in Figure 6 be used for smoothing the FX-703 lock detect signal. The circuit takes the lock detect output and performs a peak follower. When out of lock, the output is VCC - 1V. Under locked conditions, it is ground.
2. Do not leave the MODE pin floating, it should be set to logic 0 or ground for normal operation.
3. BRCLK and CBRCLK should be left floating if not used.
4. FIN, CFIN, BRCLK, and CBRCLK have internal pull-up/pull-down resistors and it is recommended to AC couple these inputs.
5. Best jitter is realized with a differential input.

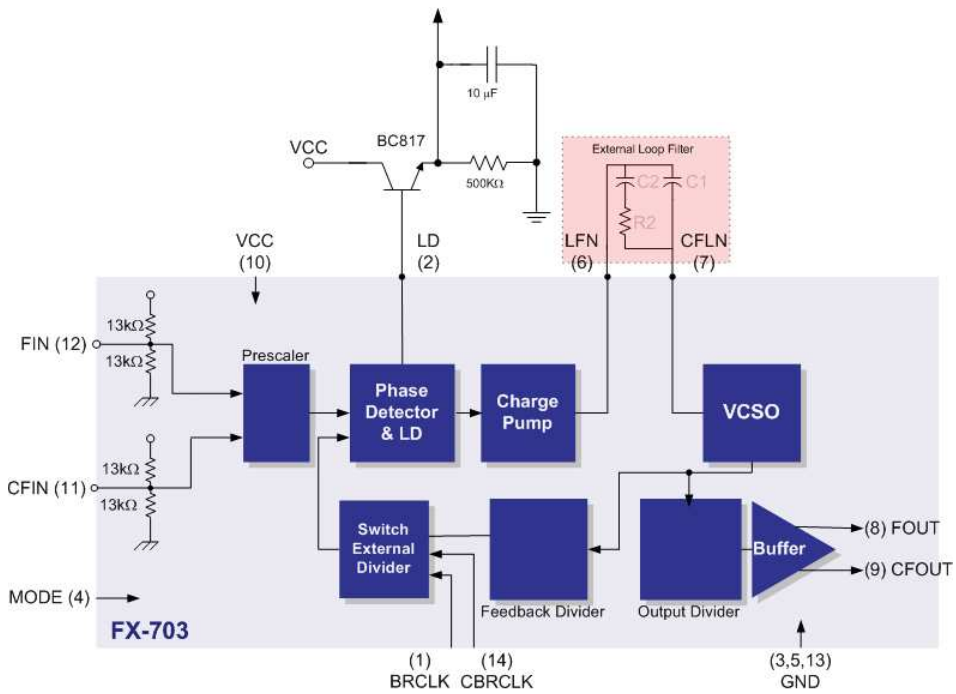

Figure 7. Typical FX-703 Application Diagram - Consult with Vectron Application Engineering for recommended Loop Filter design. The lock detect has a low current output drive with narrow pulses occurring at the phase detector edge rate even under locked conditions. Figure 7 shows one method to buffer and filter the LD output.

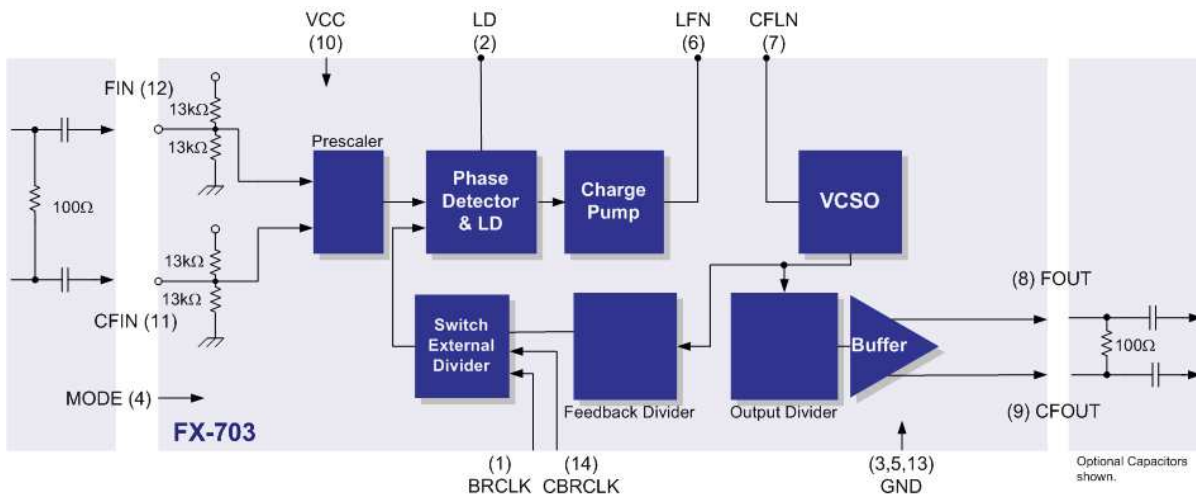

Figure 8. LVDS Input, LVDS Output The inputs, Fin and CFin, are biased with 13 kΩ pull up and pull down resistors which sets the mid supply bias on the input differential amplifier. In most applications, the input should be AC-coupled. For best signal integrity, the shown termination should be used.

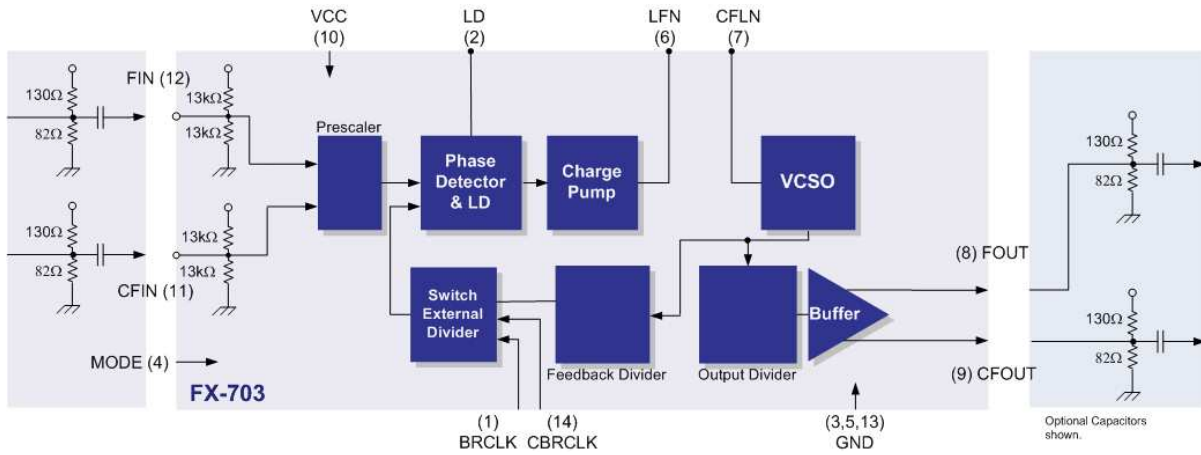

Figure 9. 50 Ohm Impedance Matching. LVPECL Input, LVPECL Output

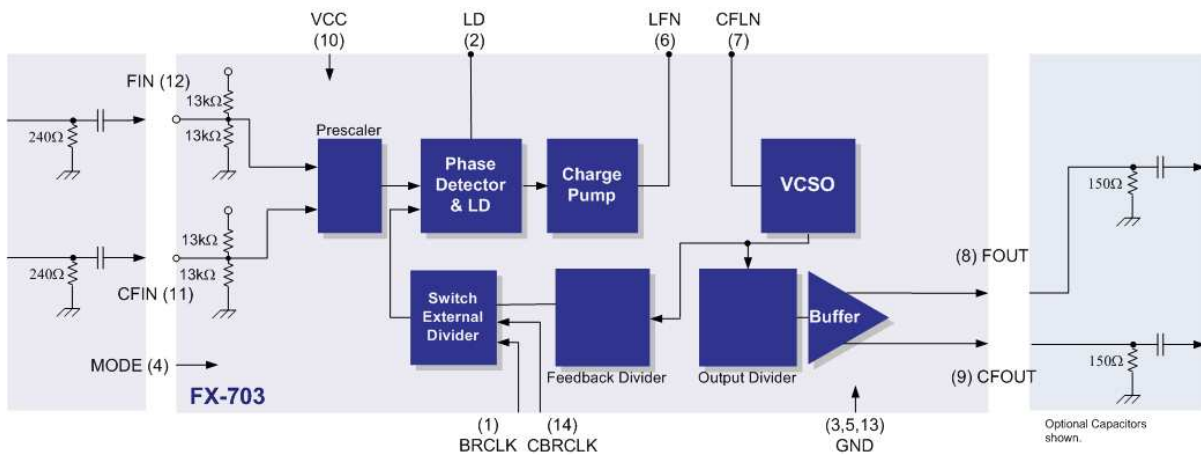

Figure 10. Alternate LVPECL Termination Scheme, Short PC Trace

Table 8. Standard Frequencies (MHz)											
18.7500000	EE	39.0625000	HH	73.7280000	K8	173.370748	ND	622.080000	P2	781.250000	T9
19.2000000	DD	39.3216000	HD	74.1250000	K1	173.437500	NP	624.693800	PD	796.875000	TB
19.3926580	DX	39.8437500	HJ	74.1758000	KA	176.838175	NA	624.704800	P6	800.000000	TK
19.4400000	D6	40.0000000	JF	74.2500000	K7	182.016000	N8	625.000000	P3	805.664100	TA
19.5312500	DZ	40.2830630	KK	75.0000000	KH	182.857142	NM	627.329600	P7	809.063500	TE
19.6608000	DB	40.9600000	J1	76.8000000	K4	184.000000	NG	629.987800	PA	819.200000	TH
19.6989680	DK	41.0888870	KM	77.7600000	K2	184.320000	NH	637.500000	PG	821.777300	TF
19.7190000	DH	41.6571440	KP	78.0000000	LH	187.500000	N5	640.000000	PN	850.000000	TJ
19.9218750	ED	41.6600000	LM	78.1250000	K3	195.000000	N7	644.531250	P4	983.400000	TU
20.0000000	E2	41.8329130	KT	78.6432000	K5	200.000000	NE	645.120000	RJ	1,000.0000	TM
20.1416000	E3	42.0000000	JB	79.6875000	KG	200.192000	N6	647.239400	PE		
20.4800000	E4	42.0101690	KV	80.0000000	K9	201.416020	N1	647.250800	PK	Recent Adds:	
20.5444340	EF	42.5000000	JC	80.5664130	KJ	212.500000	NF	649.970300	PF	10.000000	C4
20.7135000	E1	42.6600000	JZ	82.1777380	KL	219.429571	NL	657.421875	PB	174.703083	NX
20.8285720	EG	44.2095440	KX	82.9440000	K6	240.000000	NR	665.625600	PC	175.000000	W2
20.8286000	EB	44.4343000	LF	83.3142880	KN	243.000000	NC	666.514286	P5	698.812330	VC
20.9165460	EH	44.6218000	JW	83.6658250	KR	245.760000	N9	669.128100	R2		
21.0050840	EJ	44.7360000	J3	84.0203380	KU	250.000000	NT	669.326582	R3		
22.0000000	E9	44.9280000	JE	86.6853740	LJ	252.571428	NJ	669.642900	R1		
22.1047720	EK	45.1584000	JG	88.4190880	KW	256.000000	NK	670.838600	R7		
22.2171000	E5	45.8240000	JM	95.7000000	LK	262.144000	NB	672.000000	RT		
22.5792000	E8	46.0379460	LG	97.5000000	KE	292.571429	NN	672.156250	TX		
24.0000000	EC	46.7200000	JK	100.000000	L8	300.000000	PT	672.162712	R5		
24.5760000	E6	46.8750000	JY	105.000000	L6	307.200000	RX	673.456600	RA		
24.7040000	E7	48.0000000	JV	106.250000	L9	311.040000	P1	684.255400	R9		
25.0000000	F7	49.1520000	J7	108.000000	LA	312.500000	PU	687.700000	TV		
25.1658000	F8	49.4080000	J2	110.000000	L1	318.750000	PV	690.569196	R4		
25.6000000	F6	50.0000000	JD	112.000000	L2	320.000000	PP	693.468750	RV		
25.9200000	F2	50.0480000	KD	114.000000	L3	322.265650	PW	693.482991	R6		
26.0000000	F3	51.2000000	LL	120.000000	LC	328.710950	PX	693.750000	R8		
27.0000000	F4	51.8400000	J4	122.880000	LB	333.257150	PY	696.390625	RW		
27.6480000	FB	52.0000000	JP	124.416000	L7	334.663300	RB	696.421478	V1		
28.7040000	F1	53.3300000	JU	125.000000	L4	336.081350	RC	696.421875	TY		
29.4912000	F5	54.7460000	JL	130.000000	LD	353.676350	RD	704.380600	TG		
29.5000000	F9	55.0000000	JX	131.072000	LN	368.640000	RY	707.352700	TC		
30.0000000	HE	60.0000000	JR	139.264000	L5	375.000000	RF	707.500000	V2		
30.7200000	H1	61.3800000	KY	150.000000	M8	382.800000	RU	710.948600	T2		
30.8800000	HF	61.4400000	J5	150.144000	M6	400.000000	RR	712.520000	TW		
31.2500000	H8	62.2080000	J8	153.600000	MA	409.600000	RE	716.573200	T1		
32.0000000	H2	62.5000000	J9	155.520000	M2	491.520000	PM	718.750000	T5		
32.7680000	H3	62.9145000	LE	156.250000	M3	500.000000	RK	719.734400	T3		
33.0000000	H7	63.3600000	JJ	159.375000	M7	505.000000	V3	737.280000	TL		
33.3330000	HC	63.8976000	JN	160.000000	M1	531.000000	PH	739.200000	TT		
34.3680000	H6	64.0000000	JT	161.132813	M4	531.250000	P8	742.500000	V4		
34.5600000	HB	64.1520000	JH	164.355475	M9	568.928600	PJ	748.070900	T6		
36.8640000	HG	65.5360000	J6	166.628572	M5	569.196400	P9	750.000000	T7		
37.0560000	H4	66.0000000	JA	167.331646	N2	588.000000	RH	768.000000	TN		
37.1250000	H9	70.0000000	KB	168.040678	N3	595.056000	PL	777.600000	T4		
37.5000000	HK	70.6560000	KC	170.000000	N4	600.000000	PR	779.568600	T8		
38.8800000	H5	71.6100000	KF	172.500000	NU	614.400000	RG	780.881000	TD		

Ordering Information

FX-703 - E C E - K M M M - XX - XX

Product Family

FX: Frequency Translator

Package

703: 5.0 x 7.5 x 2.0mm

Input

E: 3.3 Vdc ±10%

Output

C: LVPECL
D: LVDS

Operating Temperature

E: -40° to 85 °C
T: 0° to 70°C

Absolute Pull Range

E: ± 20 ppm
H: ± 32 ppm
K: ± 50 ppm
S: ± 100 ppm

Output Frequency

(See Above)

Input Frequency

(See Above)

Prescaler

M: Factory Set

Output 2 Divider

M: Factory Set

Feedback Divider

L: Disabled (external required)
M: Factory Set

1. Not all combinations are possible. Please consult with your Vectron representative for application assistance. Other frequencies available upon request.
2. When ordering the FX-703 with the external divider option, the prescaler is set to 1. The Feedback Divider = F_{OUT}/F_{IN}

Example: **FX-703-ECE-KMMM-M3-M3** (156.25 MHz Jitter Attenuator)

Example: **FX-703-EDT-KMMM-W2-TM** (175 MHz to 1000 MHz Frequency Translator)

Revision History		
Date	Approved	Description
03Apr2012	BW	Original Release

For Additional Information, Please Contact

USA:

Vectron International
 267 Lowell Road
 Hudson, NH 03051
 Tel: 1.888.328.7661
 Fax: 1.888.329.8328

Europe:

Vectron International
 Landstrasse, D-74924
 Neckarbischofsheim, Germany
 Tel: +49 (0) 3328.4784.17
 Fax: +49 (0) 3328.4784.30

Asia:

Vectron International
 1589 Century Avenue, the 19th Floor
 Chamtime International Financial Center
 Shanghai, China
 Tel: 86.21.6081.2888
 Fax: 86.21.6163.3598

Disclaimer

Vectron International reserves the right to make changes to the product(s) and or information contained herein without notice. No liability is assumed as a result of their use or application. No rights under any patent accompany the sale of any such product(s) or information.