

Helping Customers Innovate, Improve & Grow



Features

- Low G-Sensitivity
- Vibration hardened
- Tight Tolerances
- Low Phase Noise

Applications

- Vibration Environment
- Portable Equipment
- Land Mobile Radio

Performance Specifications²

Frequency Stabilities ¹ (Standard Frequency range - 10 to 100 MHz)						
Parameter	Min	Typical	Max	Units	Condition	
vs. operating temperature range (referenced to +25°C)	-2.5		+2.5	ppm	-40 to +85°C	Options ⁴
	-1.0		+1.0	ppm	-40 to +85°C	
	-2.5		+2.5	ppm	-20 to +70°C	
	-1.0		+1.0	ppm	-20 to +70°C	
	-1.0		+1.0	ppm	-0 to +50°C	
-0.5		+0.5	ppm	-0 to +50°C		
Initial tolerance	-1.5		+1.5	ppm	at time of shipment, nominal EFC, 25°C	
vs. supply voltage change	-0.3		+0.3	ppm	V _s ±5% static	
vs. load change	-0.2		+0.2	ppm	Load ±10% static	
vs. aging / 1 year	-1.0		+1.0	ppm	after 30 days of operation	
vs. aging / 10 year	-2.5		+2.5	ppm	after 30 days of operation	
Frequency Stabilities ¹ (Stratum 3 TCXO Frequency range - 10 to 100 MHz)						
vs. operating temperature range (referenced to +25°C)	-0.8		+0.8	ppm	-40 to +85°C	Options ⁴
	-0.8		+0.8	ppm	-20 to +70°C	
	-0.28*		+0.28*	ppm	-20 to +70°C	
	-0.28*		+0.28*	ppm	-0 to +50°C	
Initial tolerance	-1.0		+1.0	ppm	at time of shipment, nominal EFC, 25°C	
vs. supply voltage change	-0.3		+0.3	ppm	V _s ±5% static	
vs. load change	-0.1		+0.1	ppm	Load ±10% static	
vs. aging / 20 years	-2.5		+2.5	ppm	after 30 days of operation	
overall tolerance	-4.6		+4.6	ppm	Note:	
* Stratum 3 per GR-1244-CORE: <±4.6 ppm for all causes and 20 Years aging, Holdover: <±0.37 ppm over 24 hours						

Performance Specifications²

Supply Voltage (Vs)							
Parameter	Min	Typical	Max	Units	Condition		
Supply voltage (standard) Current consumption	3.135	3.3	3.465 30	VDC mA	@LVCMOS	Option ⁴	
Supply voltage Current consumption	4.75	5.0	5.25 40	VDC mA	@HCMOS		
RF Output							
Signal [standard]	LVCMOS/HCMOS						
Load	13.5	15	16.5	pF			
Signal Level (Vol) LVCMOS			0.3	VDC	@ Vs=3.3V and 15pF Load		
Signal Level (Voh) LVCMOS	3.0			VDC	@ Vs=3.3V and 15pF Load		
Signal Level (Vol) HCMOS			0.5	VDC	@ Vs=5.0V and 15pF Load		
Signal Level (Voh) HCMOS	4.5				@ Vs=5.0V and 15pF Load		
Duty Cycle	40		60	%	@ (Voh-Vol)/2		
Rise and Fall time			5	ns	@15 pF 10 to 90 %		
Frequency Control (EFC)							
Tuning Range	Fixed TCXO; No adjust						Option ⁴
Tuning Range	±5.0 ±8.0	±12 ±14	±20 ±20	ppm ppm	S3 Version Standard Version		
Linearity	<10%						
Tuning Slope	Positive						
Control Voltage Range	0.3	1.65	3.0	VDC	@ Vs=3.3V		
Control Voltage Range	0.5	2.5	4.5	VDC	@ Vs=5.0V		
Frequency control input impedance	10			kOhm			
Additional Parameters							
Phase Noise ³		-95 -123 -143 -152 -155		dBc/Hz dBc/Hz dBc/Hz dBc/Hz dBc/Hz	10 Hz 100 Hz 1 kHz 10 kHz 100 kHz	@ 10 MHz LVCMOS 3.3 V	
Jitter		1.14		ps RMS	@ 12 kHz to 20 MHz		
Phase Noise ³		-74 -103 -134 -152 -160		dBc/Hz dBc/Hz dBc/Hz dBc/Hz dBc/Hz	10 Hz 100 Hz 1 kHz 10 kHz 100 kHz	@ 100 MHz LVCMOS 3.3 V	
Jitter		0.073		ps RMS	@ 12 kHz to 20 MHz		
Weight			8.0	g			
Processing & Packing	Handling & Processing Note						
Additional Environmental Conditions							
Random Vibration	MIL-STD-202G; Method 214A; Condition II-J				1g2/Hz / 43.92 grms guaranteed (Qualification testing performed at MIL-STD-202G; Method 214A; Condition II-K, 1.5g2/Hz / 53.79 grms)		
Sine Vibration	MIL-STD-883; Method 2007				Test Condition B 50 g (Qualification testing performed at MIL-STD-883; Method 2007; Test Condition C 70 g)		
Shock	MIL-STD-883G; Method 2002.4; Condition D				5000 g / 0.3 ms higher values on request		
Solderability	JEDEC J-STD-002 100% RoHS 6 compliant						
Solvent Resistance	non-washable device						
Absolute Maximum Ratings							
supply voltage (Vs)			6.0	V			
Output Load			50	pF			

Absolute Maximum Ratings

Operable Temperature Range	-40	+85	°C
Storage Temperature Range	-55	+105	°C

Outline Drawing / Enclosure

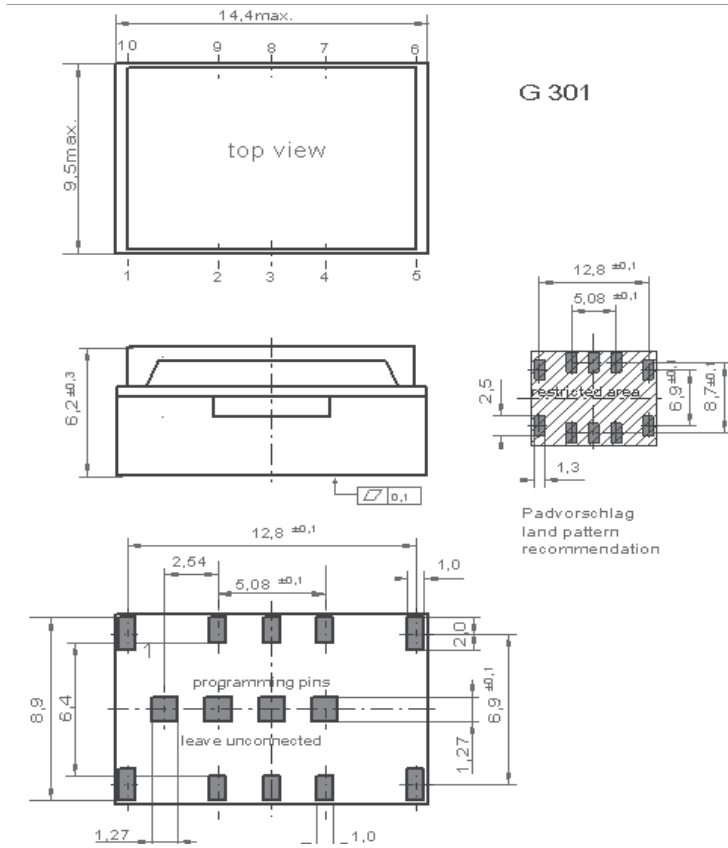

Dimensions in mm

TX-508

Height "H"	Pin Length "L"
6.2	NA

Pin Connections

1	N/C
2	NC / Control Voltage Input (Vc)
3	N/C / Enable (optional)
4	Ground (Case)
5	NC
6	NC
7	RF-Output
8	NC
9	Supply Voltage (Vs)
10	NC

Enable true table (optional)

Pin 3	Pin 7
High	Data
Open	Data
Low	High Tristate

Typical Phase Noise @ 100 MHz HCMOS

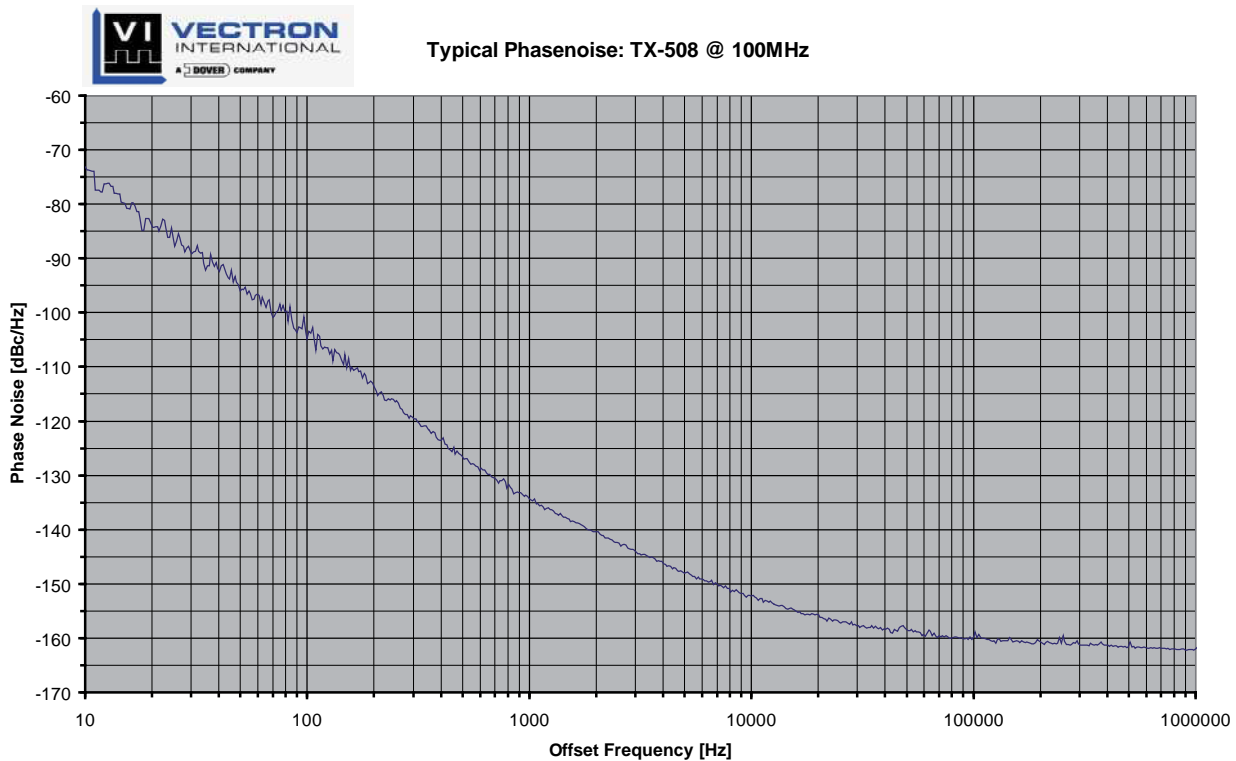

Typical G-Sensitivity @10 MHz; HCMOS

G-Sensitivity: TX-508; 10 MHz; 0,06g2/Hz

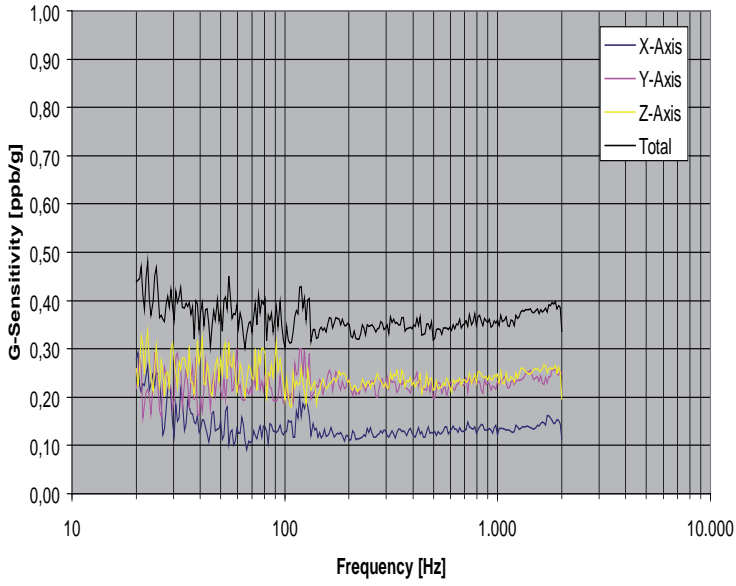

Vibration spectrum

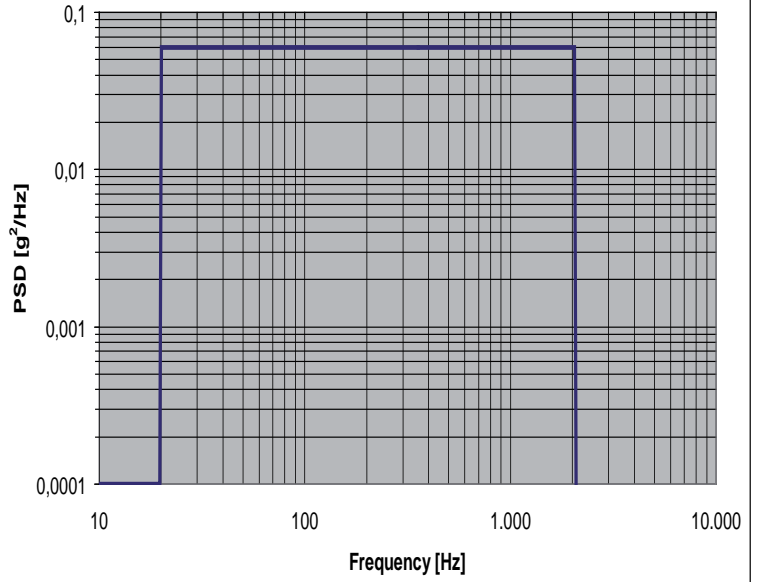

Phase noise: TX-508; 10 MHz; 0,06g2/Hz

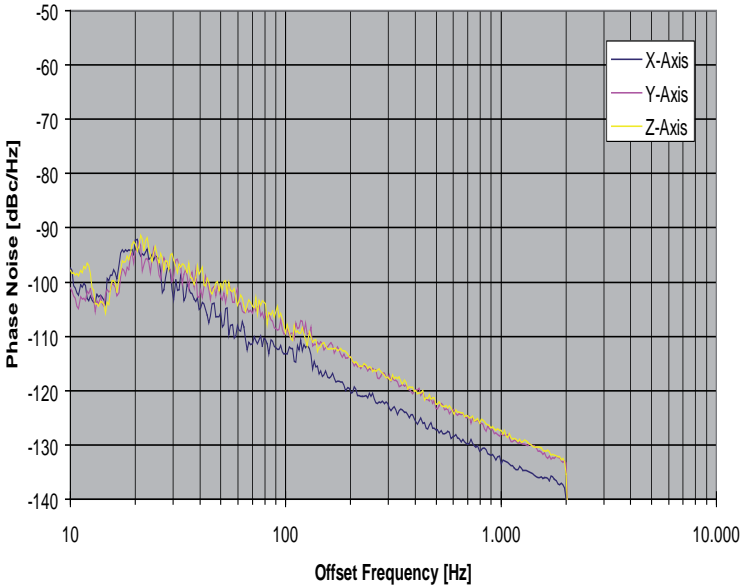

Calculation equation according to Vig-Tutorial

$$g\text{-sensitivity: } G = \frac{2 \cdot f_v}{A_{peak} \cdot f_0} \cdot 10^{\frac{L(f_v)}{20}}$$

$$\text{Peak g-level: } A_{peak} = \sqrt{PSD \cdot 2}$$

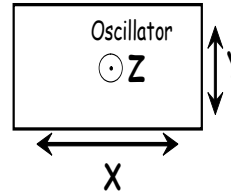

Standard Shipping Method (TX-508)

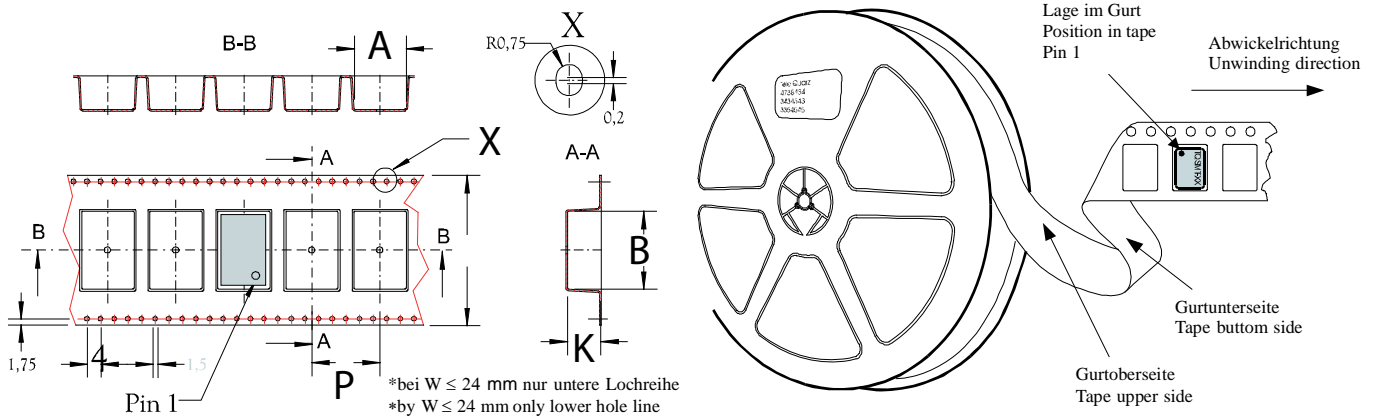

Enclosure Type	Tape Width W (mm)	Quantity per meter	Quantity per reel	Dimension P
G301	24	83,3	850	12

Recommended Reflow Profile

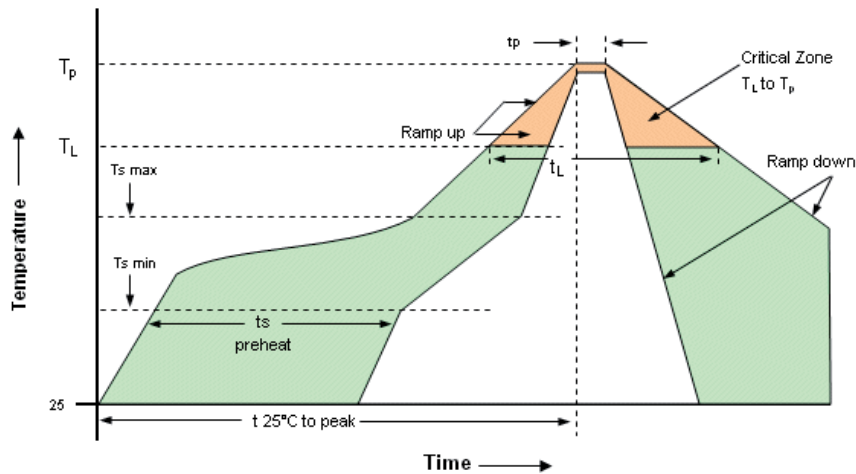

Profile Feature	Pb-Free Assembly/ Sn-Pb Assembly	Profile Feature	Pb-Free Assembly/ Sn-Pb Assembly
Average ramp-up rate (T_L to T_p)	3°C/second max.	Time 25°C to Peak Temperature	8 minutes max.
Preheat -Temperature Min T_{Smin} -Temperature Min T_{Smax} -Time (min to max) t_s	150°C 200°C 60-180 seconds	Time maintained above -Temperature (T_L) -Time (t_L)	217°C 60-150 seconds
T_{Smax} to T_L -Ramp-up Rate	3°C/second max		
Time maintained above -Temperature (T_L) -Time (t_L)	217°C 60-150 seconds	Time within 5°C of actual Peak Temperature (t_p)	20-40 seconds
Peak Temperature (T_p)	max 260°C	Ramp-down Rate	6°C/ second max

Note: All temperatures refer to topside of the package, measured on the package body surface.

Ordering Information

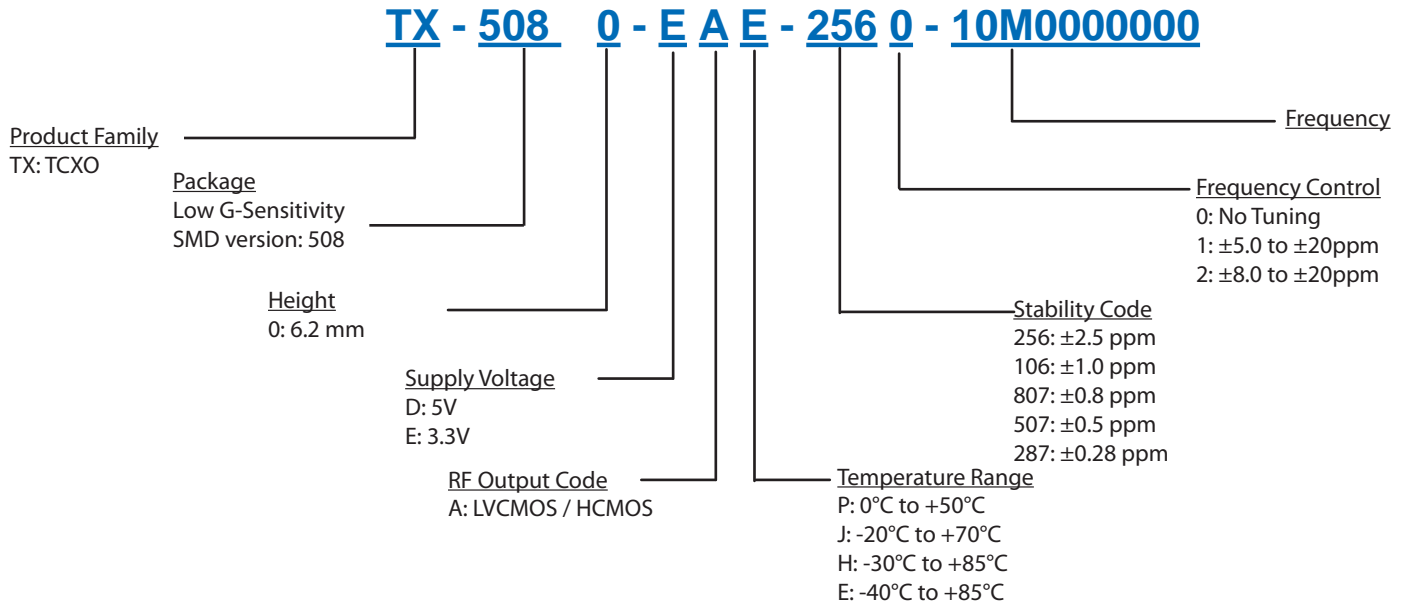

Notes:

1. Contact factory for improved stabilities or additional product options. Not all options and codes are available at all frequencies.
2. Unless other stated all values are valid after warm-up time and refer to typical conditions for supply voltage, frequency control voltage, load, temperature (25°C).
3. Phase noise degrades with increasing output frequency.
4. Contact factory for availability.

Subject to technical modification.

For Additional Information, Please Contact

USA:

Vectron International
267 Lowell Road
Hudson, NH 03051
Tel: 1.888.328.7661
Fax: 1.888.329.8328

Europe:

Vectron International
Landstrasse, D-74924
Neckarbischofsheim, Germany
Tel: +49 (0) 7268.801.100
Fax: +49 (0) 7268.801.282

Asia:

Vectron International
1589 Century Avenue, the 19th Floor
Chamtime International Financial Center
Shanghai, China
Tel: 86.21.6081.2888
Fax: 86.21.6163.3598

Disclaimer

Vectron International reserves the right to make changes to the product(s) and or information contained herein without notice. No liability is assumed as a result of their use or application. No rights under any patent accompany the sale of any such product(s) or information.

Rev: 06/2011