



Helping Customers Innovate, Improve & Grow



### Description

Vectron's VT-822 Temperature Compensated Crystal Oscillator (TCXO) is a quartz stabilized, CMOS output, analog temperature compensated oscillator, operating off either a 2.5 or 3.3 volt supply, in a hermetically sealed 3.2x2.5 ceramic package.

### Features

- CMOS Output
- Output Frequencies to 54 MHz
- Enable Disable Function
- Fundamental Crystal Design
- Hermetically Sealed Ceramic SMD package
- Product is compliant to RoHS directive  and fully compatible with lead free assembly

### Applications

- WiMAX, Wi-Fi, Wi-LAN
- Wireless Communications
- Base Stations
- Point to point radios
- Broadband Access
- Test Equipment
- Handsets
- Networking

### Block Diagram

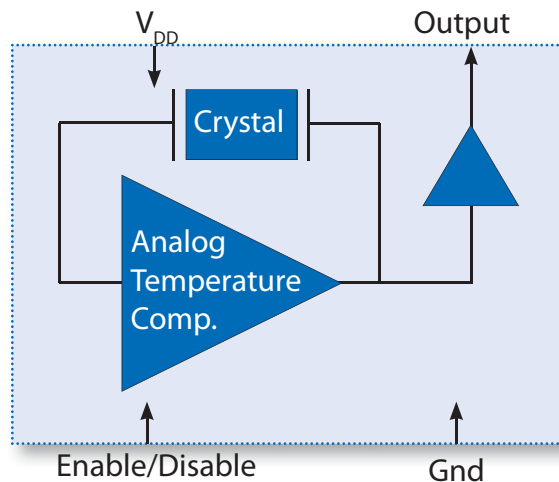

# Specifications

Table 1. Electrical Performance					
Parameter	Symbol	Min.	Typ	Max	Units
Output Frequency	$f_o$	4		54	MHz
Supply Voltage, <sup>1</sup> (Ordering Option)	$V_{DD}$	+2.5 or +3.3			V
Supply Current, to 19.999 MHz 20.001 - 55.000MHz	$I_{DD}$			3.0 7.0	mA
Operating Temperature, (Ordering Option)	$T_{OP}$	-20/70 or -40/85			°C
STABILITY					
Stability Over $T_{OP}$ , (Ordering Option)		±2.0, ±2.5, ±5.0			ppm
Initial Accuracy <sup>2</sup>				±2.0	ppm
Power Supply Stability				±0.2	ppm
Load Stability				±0.2	ppm
Aging				±1.0	ppm/1st yr
OUTPUT					
Output Level <sup>2</sup>	$V_{OH}$ $V_{OL}$	$0.9 \cdot V_{DD}$		$0.1 \cdot V_{DD}$	V
Output Load				15pF	
Output Rise and Fall Time				5	ns
Duty Cycle		45		55	%
Phase Noise, 10.000MHz 10Hz 100Hz 1kHz 10kHz 100kHz			-75 -111 -141 -152 -156		dBc/Hz
Jitter <sup>3</sup>			2.1 20.0		ps rms ps pk-pk
Start-Up Time				2	ms
ENABLE/DISABLE					
Output Enabled		$0.7 \cdot V_{DD}$ or open			V
Output Disabled				$0.3 \cdot V_{DD}$	V
Package Size		3.2x2.5			

1. The VT-822 power supply pin should be filtered, eg, a 10uF, 0.1 and 0.01uf capacitor

2. Initial accuracy is guaranteed sixty minutes after a 260C reflow.

3. The Output is DC coupled.

4. Jitter is measured is a Wavecrest SIA3300C, 90K samples

## Outline Drawing and Recommended Layout

**Table 2. Pinout**

Pin #	Symbol	Function
1	E/D	Enable/Disable
2	GND	Electrical and Lid Ground
3	$f_o$	Output Frequency
4	$V_{DD}$	Supply Voltage

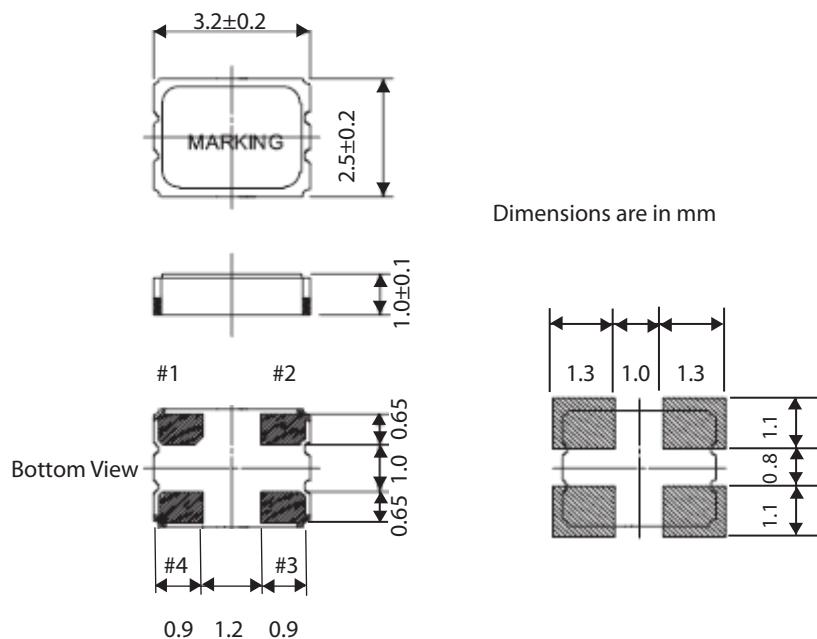

## Maximum Ratings

### Absolute Maximum Ratings and Handling Precautions

Stresses in excess of the absolute maximum ratings can permanently damage the device. Functional operation is not implied or any other excess of conditions represented in the operational sections of this data sheet. Exposure to absolute maximum ratings for extended periods may adversely affect device reliability.

Although ESD protection circuitry has been designed into the VT-822, proper precautions should be taken when handling and mounting, VI employs a Human Body Model and Charged Device Model for ESD susceptibility testing and design evaluation.

ESD thresholds are dependent on the circuit parameters used to define the model. Although no industry standard has been adopted for the CDM a standard resistance of 1.5kOhms and capacitance of 100pF is widely used and therefor can be used for comparison purposes.

**Table 3. Maximum Ratings**

Parameter	Symbol	Rating	Unit
Storage Temperature	$T_{STORE}$	-40/125	°C
Supply Voltage	$V_{DD}$	-0.3/4	V
Enable Disable Voltage	E/D	$V_{DD}$	V
ESD, Human Body Model	HBM	1500	V
ESD, Charged Device Model	CDM	1000	V

Table 4. Environmental Compliance	
Parameter	Condition
Mechanical Shock	MIL-STD-883 Method 2002
Mechanical Vibration	MIL-STD-883 Method 2007
Temperature Cycle	MIL-STD-883 Method 1010
Solderability	MIL-STD-883 Method 2003
Fine and Gross Leak	MIL-STD-883 Method 1014
Resistance to Solvents	MIL-STD-883 Method 2015
Moisture Sensitivity Level	MSL1
Contact Pads	Gold (0.3um min - 1.0um max) over Nickel

## IR Reflow

### Suggested IR Profile

Devices are built using lead free epoxy and can be subjected to standard lead free IR reflow conditions shown in Table 5. Contact pads are gold over nickel and lower maximum temperatures can also be used, such as 220C.

Table 5. Reflow Profile		
Parameter	Symbol	Value
PreHeat Time	$t_s$	200 sec Max
Ts-min		150°C
Ts-max		200°C
Ramp Up	$R_{UP}$	3°C/sec Max
Time above 217C	$t_L$	150 sec Max
Time to Peak Temperature	$t_{25C\ to\ peak}$	480 sec Max
Time at 260C	$t_p$	10 sec Max
Time at 240C	$t_{p2}$	60 sec Max
Ramp down	$R_{DN}$	6°C/sec Max

### Solderprofile:

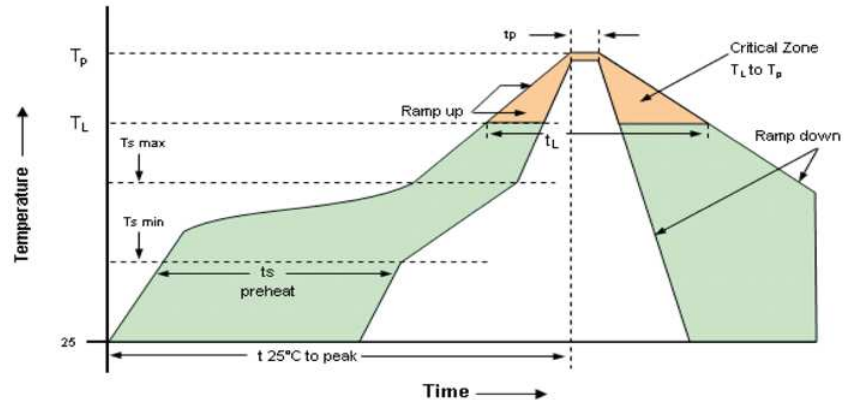

## Tape & Reel

Table 6. Tape and Reel Information

Tape Dimensions (mm)					Reel Dimensions (mm)							
W	F	Do	Po	P1	A	B	C	D	N	W1	W2	#/Reel
18	1.75	1.55	4	4	178	2.5	13	22	60	11.5	15	1000

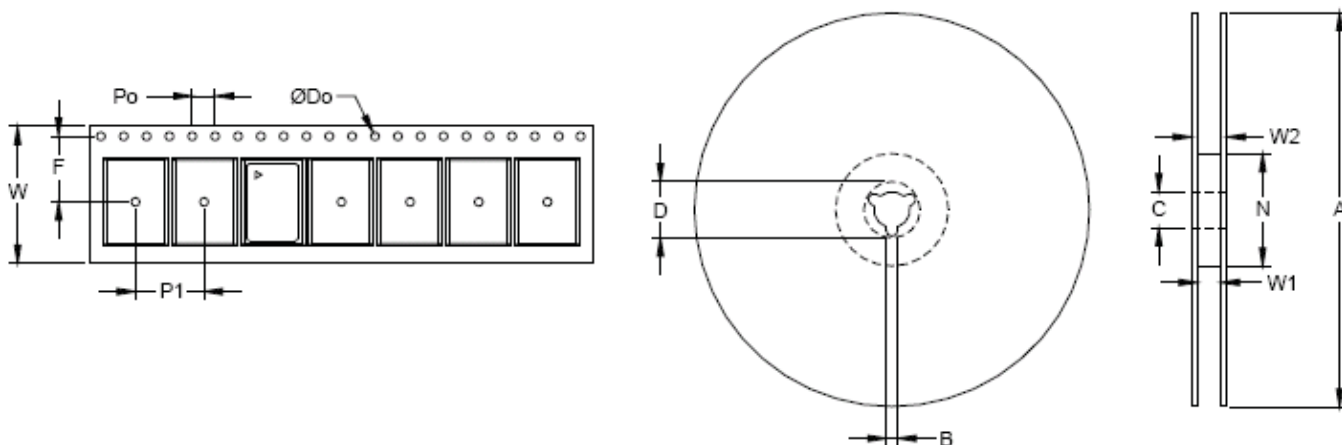

**Table 7. Standard Frequencies (MHz)**

8.1920	10.000	10.250	12.000	12.800	13.000	14.000	14.7456	15.360	15.000
16.000	16.376	16.366667	16.367667	16.3677673	16.368	16.369	16.736	16.800	19.200
19.6608	19.680	19.680	20.000	22.000	25.000	26.000	27.000	27.4560	30.4000
30.720	38.400	40.000	45.000	50.000	52.000				

## Ordering Information

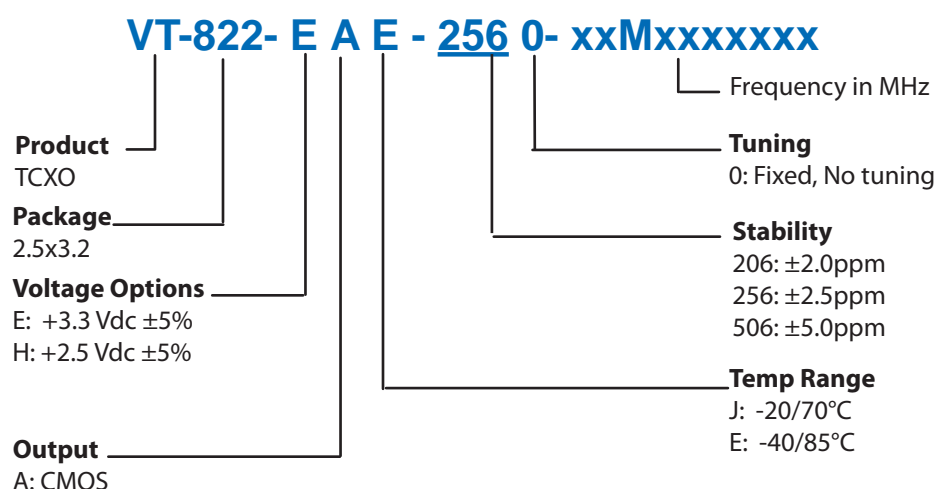

*\*Note: not all combination of options are available.  
Other specifications may be available upon request.*

**Example: VT-822-EAE-2560-10M0000000**

## For Additional Information, Please Contact

### USA:

Vectron International  
267 Lowell Road  
Hudson, NH 03051  
Tel: 1.888.328.7661  
Fax: 1.888.329.8328

### Europe:

Vectron International  
Landstrasse, D-74924  
Neckarbischofsheim, Germany  
Tel: +49 (0) 3328.4784.17  
Fax: +49 (0) 3328.4784.30

### Asia:

VI Shanghai  
1589 Century Avenue, the 19th Floor  
Chamtime International Financial Center  
Shanghai, China  
Tel: 86.21.6081.2888  
Fax: 86.21.6163.3598

### Disclaimer

Vectron International reserves the right to make changes to the product(s) and or information contained herein without notice. No liability is assumed as a result of their use or application. No rights under any patent accompany the sale of any such product(s) or information.

Rev: 03/30/2012