



Helping Customers Innovate, Improve & Grow



Description

Vectron's VT-800 Temperature Compensated Crystal Oscillator (TCXO) is a quartz stabilized, clipped sine wave output, temperature compensated oscillator, operating off either 2.8, 3.0, 3.3 or 5.0 volt supply, hermetically sealed 3.2x5 ceramic package.

Features

- Clipped Sine Wave Output
- Output Frequencies to 40 MHz
- Fundamental Crystal Design
- Optional VCXO Function available
- Gold over nickel contact pads
- Hermetically Sealed Ceramic SMD package
- Product is compliant to RoHS directive  and fully compatible with lead free assembly

Applications

- Wireless Communications
- Base Stations
- Point to point radios
- Broadband Access
- Test Equipment
- Handsets

Block Diagram

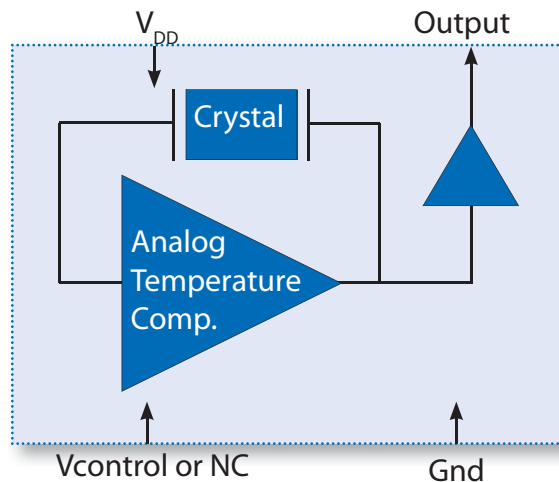

Specifications

Table 1. Electrical Performance

Parameter	Symbol	Min.	Typ	Max	Units
Output Frequency, +5V option +2.8, +3.0, +3.3V options	f_o	10 10		27 40	MHz
Supply Voltage ¹	V_{DD}	+2.8, +3.0, +3.3 or +5.0			V
Supply Current, 8 to 14.999MHz 15.000 to 25.999MHz 26.000 to 40.000MHz	I_{DD}			1.5 2.0 2.5	mA
Operating Temperature, <i>ordering option</i>	T_{OP}	0/55, -10/60, -20/70, -30/80, -40/85			°C
Stability Over TOP, <i>ordering option</i>		±0.5, ±1.0, ±1.5, ±2.0, ±2.5, ±3.0, ±4.0, ±5.0			ppm
Initial Accuracy, "No Adjust" Option				±1.0	ppm
Power Supply Stability				±0.2	ppm
Load Stability				±0.2	ppm
Aging				±1.0	ppm/yr
Pull Range, <i>ordering option</i>	TPR	±5, ±8, ±10, ±12			ppm
Control Voltage to reach Pull Range		0.5		2.5	V
Control Voltage Impedance		1			Mohm
Output Level ²	V_o p/p	0.8			V
Output Load				10K 10pF	
Phase Noise, 10.000MHz 10Hz 100Hz 1kHz 10kHz 100kHz			-91 -116 -137 -149 -150		dBc/Hz
Start Up Time				10	ms

1. The VT-800 power supply pin should be filtered, eg, a 0.1 and 0.01uf capacitor
2. The Output is DC coupled

Outline Drawing

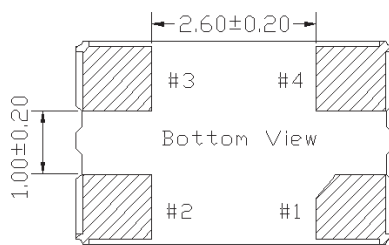
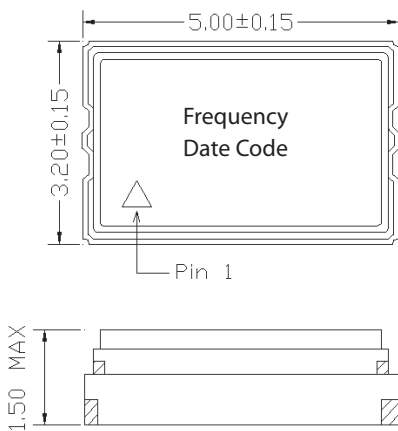

Dimensions in mm

Recommended Pad Layout

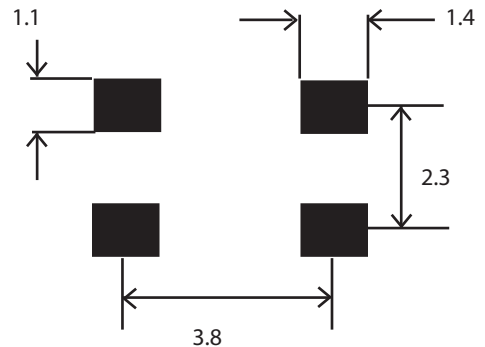

Table 2. Pinout

Pin #	Symbol	Function
1	V_C	TCXO Control Voltage or Ground
2	GND	Electrical and Lid Ground
3	f_o	Output Frequency
4	V_{DD}	Supply Voltage

VCXO Function

VCXO Feature: The VT-800 can be ordered with a VCXO function for applications where it will be used in a PLL, or the output frequency needs fine tune or calibration adjustments. This is a high impedance input, 1Mohm, and can be driven with an op-amp or terminated with adjustable resistors etc. **Pin 1 should not be left floating on the VCXO optional device.**

“No Adjust” Option: In applications where the VT-800 will not be used in a PLL, or the output frequency does not need fine tune adjustments, the best device to use would be a VT-800-xxx-xxx0. By using the “no adjust” option, the circuit is simplified as V_c does not need to be adjusted or set to a predetermined voltage and pin 1 should be grounded (pin 1 can be left open but should not be set to a voltage such as an RF signal or power supply voltage).

Clipped Sine Wave Output



Phase Noise for a Clipped Sinewave Output

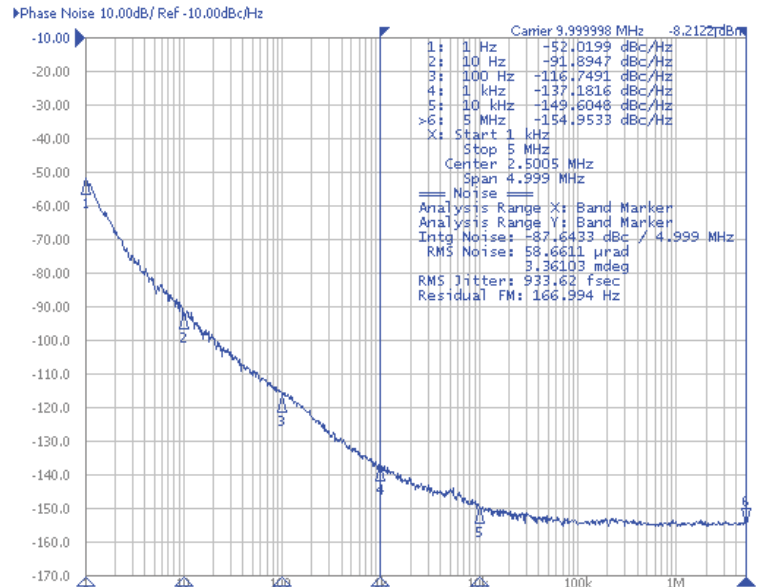

Maximum Ratings

Absolute Maximum Ratings and Handling Precautions

Stresses in excess of the absolute maximum ratings can permanently damage the device. Functional operation is not implied or any other excess of conditions represented in the operational sections of this data sheet. Exposure to absolute maximum ratings for extended periods may adversely affect device reliability.

Although ESD protection circuitry has been designed into the VT-800, proper precautions should be taken when handling and mounting, VI employs a Human Body Model and Charged Device Model for ESD susceptibility testing and design evaluation.

ESD thresholds are dependent on the circuit parameters used to define the model. Although no industry standard has been adopted for the CDM a standard resistance of 1.5kOhms and capacitance of 100pF is widely used and therefore can be used for comparison purposes.

Table 3. Maximum Ratings			
Parameter	Symbol	Rating	Unit
Storage Temperature	T_{STORE}	-55/125	°C
Supply Voltage	V_{DD}	6	V
Control Voltage	V_C	0/ V_{DD}	V
ESD, Human Body Model		1500	V
ESD, Charged Device Model		1000	V

Table 4. Environmental Compliance	
Parameter	Condition
Mechanical Shock	MIL-STD-883 Method 2002
Mechanical Vibration	MIL-STD-883 Method 2007
Temperature Cycle	MIL-STD-883 Method 1010
Solderability	MIL-STD-883 Method 2003
Fine and Gross Leak	MIL-STD-883 Method 1014
Resistance to Solvents	MIL-STD-883 Method 2015
Moisture Sensitivity Level	MSL1
Contact Pads	Gold over Nickel

IR Reflow

Suggested IR Profile

Devices are built using lead free epoxy and can be subjected to standard lead free IR reflow conditions shown in Table 5. Contact pads are gold over nickel and lower maximum temperatures can also be used, such as 220C.

Table 5. Reflow Profile		
Parameter	Symbol	Value
PreHeat Time	t_s	200 sec Max
Ts-min		150°C
Ts-max		200°C
Ramp Up	R_{UP}	3°C/sec Max
Time above 217C	t_L	150 sec Max
Time to Peak Temperature	$t_{25C \text{ to peak}}$	480 sec Max
Time at 260C	t_p	10 sec Max
Time at 240C	t_{p2}	60 sec Max
Ramp down	R_{DN}	6°C/sec Max

Solderprofile:

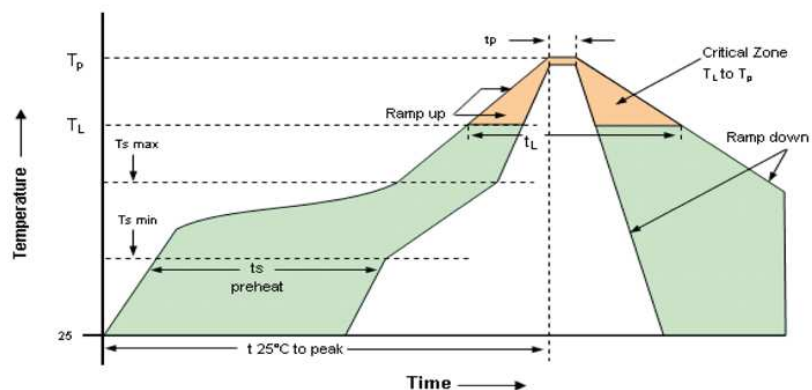

Tape & Reel

Table 6. Tape and Reel Information

Tape Dimensions (mm)					Reel Dimensions (mm)							
W	F	Do	Po	P1	A	B	C	D	N	W1	W2	#/Reel
16	7.5	1.5	4	8	180	1.5	13	20.2	60	16.4	20.4	1000

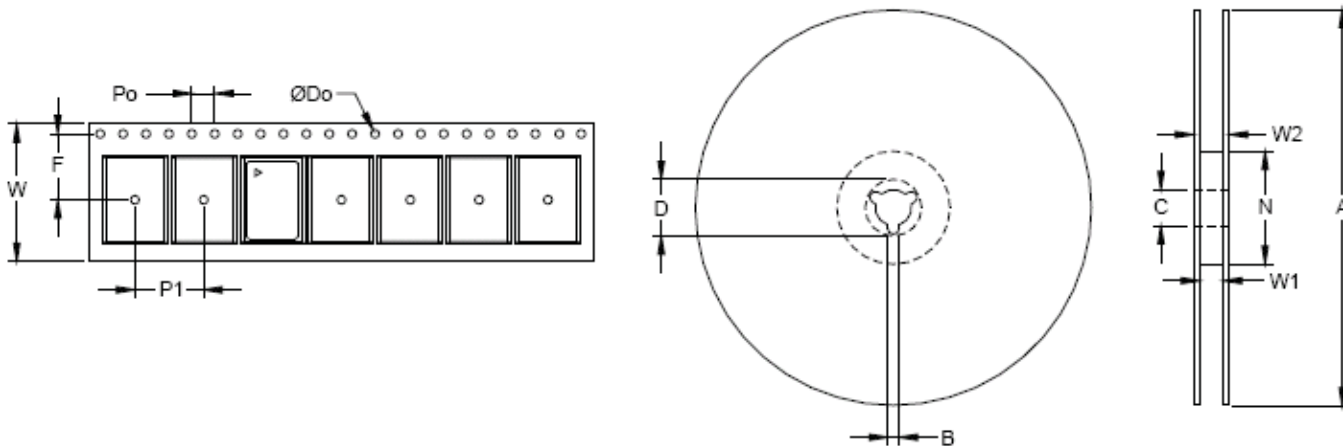

Ordering Information

Table 7. Standard Frequencies (MHz)

10.000	10.245	12.504	12.800	13.000	13.568	14.000	14.31818	14.4844	14.7456
15.000	16.000	16.325291	16.36625	16.367667	16.3683	16.396	16.800	17.500	18.414
19.200	19.440	19.6608	19.680	19.800	20.000	20.910	21.250	23.104	24.000
24.5454	24.5535	24.576	25.000	25.600	26.000	27.000	27.456	28.800	32.768
40.000									

VT-800- E F G - 206A- xxMxxxxxxx

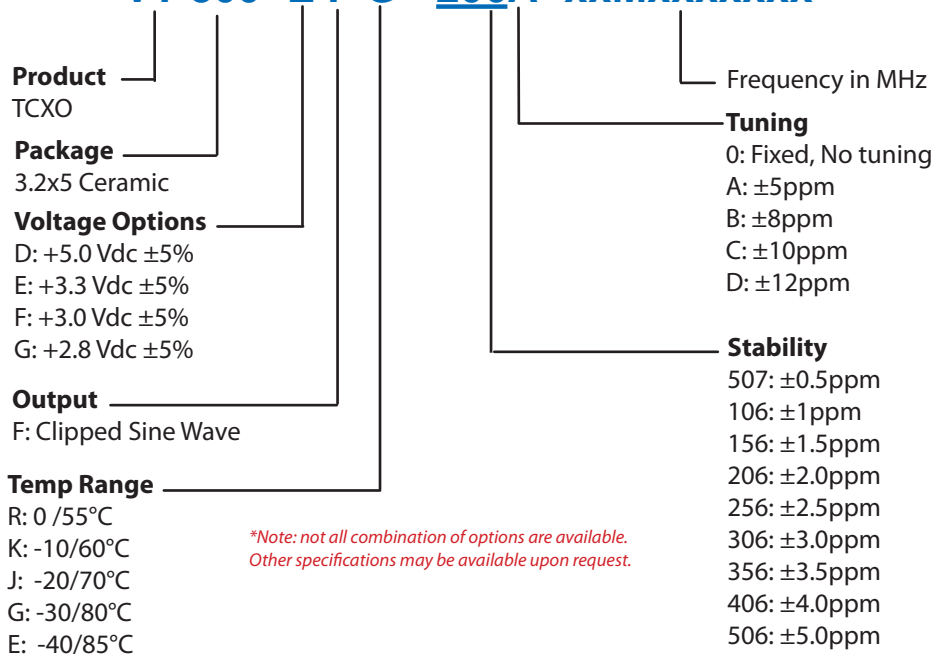

Example: VT-800-EFG-206A-26M0000000

For Additional Information, Please Contact

USA:

Vectron International
267 Lowell Road
Hudson, NH 03051
Tel: 1.888.328.7661
Fax: 1.888.329.8328

Europe:

Vectron International
Landstrasse, D-74924
Neckarbischofsheim, Germany
Tel: +49 (0) 3328.4784.17
Fax: +49 (0) 3328.4784.30

Asia:

Vectron International
1F-2F, No 8 Workshop, No 308 Fenju Road
WaiGaoQiao Free Trade Zone
Pudong, Shanghai, China 200131
Tel: 86.21.5048.0777
Fax: 86.21.5048.1881

Disclaimer

Vectron International reserves the right to make changes to the product(s) and/or information contained herein without notice. No liability is assumed as a result of their use or application. No rights under any patent accompany the sale of any such product(s) or information.

Rev: 1/10/2009